



Departament de Teoria  
del Senyal i Comunicacions



UNIVERSITAT POLITÈCNICA DE CATALUNYA

Ph.D. Thesis

MULTI LOOK-UP TABLE DIGITAL  
PREDISTORTION FOR RF POWER  
AMPLIFIER LINEARIZATION

Author: Pere Lluís Gilabert Pinal

Advisors: Dr. Eduard Bertran Albertí  
Dr. Gabriel Montoro López

Control Monitoring and Communications Group  
Department of Signal Theory and Communications  
Universitat Politècnica de Catalunya

Barcelona, December 2007

## Chapter 2

# Problem Statement: The Requirements for Linearity

### 2.1 Nonlinear Distortion of an Amplifier

#### 2.1.1 Series Representation of a Nonlinear Amplifier

An *ideal memoryless power amplifier* presents a linear transfer characteristic, where the output voltage is a scalar multiple of the input voltage. Let  $v_{in}(t)$  be the amplifier's input voltage,  $v_{out}(t)$  the amplifier's output voltage,  $T[\cdot]$  the transfer function and  $g_1$  the scalar voltage gain, therefore the linear amplification can be expressed as,

$$v_{out}(t) = T[v_{in}] = g_1 v_{in}(t) \quad (2.1)$$

By considering an ideal linear amplification, the PA's output will be identical to the input (except for the scalar gain) and no additional in-band or out-of-band frequency components will be introduced. However, even when considering a linear transfer function, distortion regarding the PA dynamics can appear and this kind of distortion is known as *linear distortion*. Let us consider following transfer function,

$$H(\omega) = |H(\omega)| e^{j\theta(\omega)} \quad (2.2)$$

The amplitude linear distortion will appear when,

$$|H(\omega)| \neq g_1 \text{ (cte)} \quad \forall \omega \quad (2.3)$$

and the phase linear distortion is expressed as,

$$\theta(\omega) \neq \omega \text{ (linear)} \quad \forall \omega \quad (2.4)$$

This linear distortion can be easily compensated by using linear filters.

Nevertheless, a more realistic definition consists in defining the power amplifier as a nonlinear system where the output signal is a nonlinear function of the input signal. From a practical point of view, the effects are represented by a spectrum distortion on the signal traveling through the nonlinear system. The *nonlinear distortion phenomena* are inherent of the active devices, such as amplifiers and oscillators, but also appear in some passive devices, like mixers, due to its nonlinear behavior.

Assuming a memoryless PA, so then neglecting memory effects, the PA output voltage signal  $v_{out}(t)$  can be modeled by a polynomial expression [Ped03], that is, a series of terms proportional to the input signal amplitude  $v_{in}(t)$  and their higher order terms,

$$v_{out}(t) \approx \sum_{k=1}^{\infty} g_k v_{in}^k(t) \quad (2.5)$$

where  $g_k$  are voltage gains of each of the series terms respectively. The first term of this series is the *linear term* and corresponds to the desired output signal. Even order terms of this polynomial series ( $v_{in}^2, v_{in}^4, \dots, v_{in}^{2k}$ ) are responsible of introducing additional frequency components at multiples of the carrier frequency (harmonics) of the input signal. This nonlinear distortion introduced by even order terms is called *Harmonic Distortion* (HD). While odd terms ( $v_{in}^3, v_{in}^5, \dots, v_{in}^{2k-1}$ ) are responsible for introducing frequency components that, some of them, fall too close to the desired signal that cannot be canceled by filtering. These intermodulation products are responsible for the so called *InterModulation Distortion* (IMD). In addition, some frequency components derived from specific nonlinear combinations fall directly inside the signal bandwidth generating the *in-band distortion*.

### 2.1.2 Power Amplifier Nonlinear Effects and Common Nonlinearity Measures

Let us consider a modulated signals containing information in both amplitude and phase (polar form) or in both In-phase (I) and Quadrature (Q) components (Cartesian form), it will be necessary to have information of the distortion suffered in both amplitude and phase (or I and Q components).

A first useful measure to observe the effects of nonlinear distortion introduced by the PA can be carried out through the *AM-AM* and *AM-PM* characterization. The *AM-AM* is a conversion between the amplitude modulation present on the input signal and the modified amplitude modulation present on the output signal. It provides information on the nonlinear relationship between the input power and the output power. The *AM-PM* is a conversion from amplitude modulation on the input signal to phase modulation on the output signal. In particular, if we consider that the PA presents a bandpass memoryless nonlinear behavior and  $v_{in}(t)$  being,

$$v_{in}(t) = A(t) \cos[\omega_c t + \varphi(t)] \quad (2.6)$$

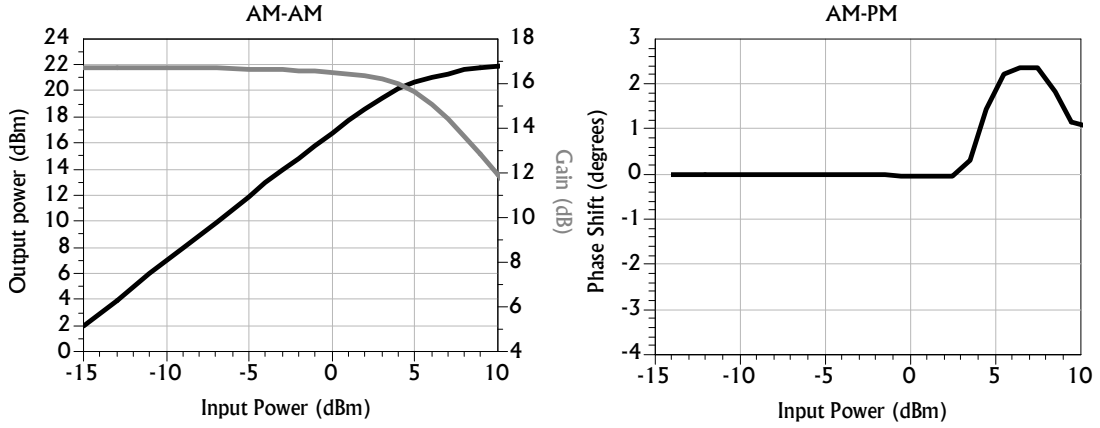

**Figure 2.1:** AM-AM and AM-PM characteristics.

the distorted output signal  $v_{out}(t)$  can be represented as:

$$v_{out}(t) = G[A(t)] \cos[\omega_c t + \varphi(t) + \Phi[A(t)]] \quad (2.7)$$

where the output signal is a sinusoidal waveform at carrier frequency ( $\omega_c$ ) whose amplitude is a nonlinear function of the input signal amplitude  $G[A(t)]$  and its phase is also a nonlinear function of the input signal amplitude  $\Phi[A(t)]$ . Figure 2.1 shows an example of the PA AM-AM and AM-PM characteristics, where it is possible to observe the gain and phase nonlinear distortion introduced by the PA at high levels of input power.

On the other hand, Fig. 2.2 shows some common measures that are used for characterizing the PA nonlinear behavior, such as the *saturation point*, the *1dB compression point* and the *Input and Output Back-Off* (IBO and OBO). The *1 dB compression point* ( $P_{1dB}$ ) is the output power value where the difference between the amplifier linear gain and actual nonlinear gain is equal to 1 dB, that is, the gain has suffered 1dB compression.

Another significant measure for the characterization of the amplifier is the *Peak to Average Power Ratio* (PAPR) of the signals. The PAPR is the ratio between the maximum value ( $P_{peak}$ ) of the instantaneous power and the average power ( $P_{average}$ ) of the signal [Ken00].

$$PAPR [dB] = 10 \log_{10} \left( \frac{P_{peak}}{P_{average}} \right) \quad (2.8)$$

The PAPR of a signal is obtained from the *probability density function* (PDF) of the envelope, which gives the relative amount of time that an envelope spends in one particular amplitude value. This parameter is important because in order to operate with linear amplification, it is necessary to operate far from the *saturation point*, that means back-off operation (see Fig. 2.2).

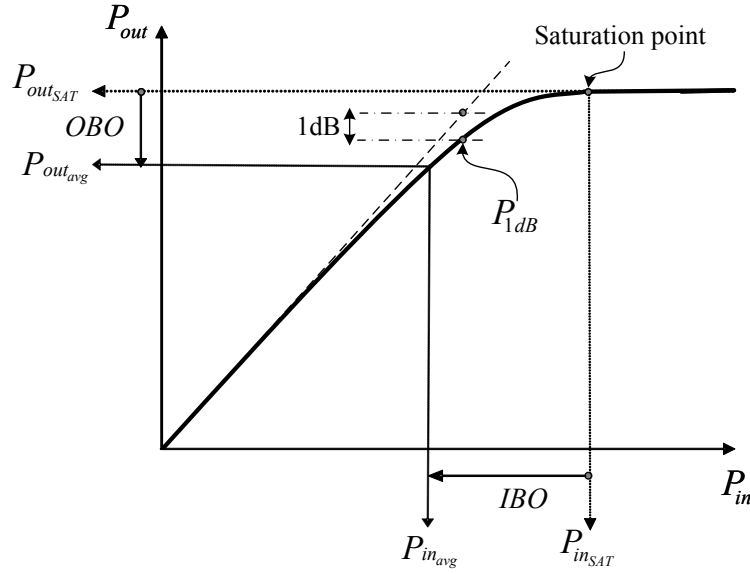

**Figure 2.2:** Power amplifier characteristic measurements.

Back-off values are not only dependent on the amplifier linearity but also on the signal PAPR, and can be given either as an input back-off (IBO) or output back-off (OBO),

$$IBO [dB] = P_{in_{SAT}} [dBm] - P_{in_{avg}} [dBm] \quad (2.9)$$

$$OBO [dB] = P_{out_{SAT}} [dBm] - P_{out_{avg}} [dBm] \quad (2.10)$$

where  $P_{in_{SAT}}$  and  $P_{out_{SAT}}$  are the input and output saturated power, and where  $P_{in_{avg}}$  and  $P_{out_{avg}}$  are the average input and output power respectively.

### 2.1.3 Power Amplifier Two-tone Test and Nonlinearity Measures

A typical test to see the nonlinear distortion introduced by the PA is the *two-tone test*. It consists in feeding the PA with two tones separated in frequency ( $\Delta f$ ),

$$v_{in}(t) = V_1 \cos(\omega_1 t) + V_2 \cos(\omega_2 t) \quad (2.11)$$

$$\omega_1 = 2\pi(f_c - \frac{\Delta f}{2}), \quad \omega_2 = 2\pi(f_c + \frac{\Delta f}{2})$$

For simplicity let us consider only the first three terms in (2.5). The output signal will be,

$$\begin{aligned}
v_{out}(t) = & \frac{g_2 V_1^2}{2} + \frac{g_2 V_2^2}{2} + \\
& + V_1 \left[ g_1 + \frac{3g_3 V_1^2}{4} + \frac{3g_3 V_2^2}{2} \right] \cos(\omega_1 t) + \\
& + V_2 \left[ g_1 + \frac{3g_3 V_2^2}{4} + \frac{3g_3 V_1^2}{2} \right] \cos(\omega_2 t) + \\
& + \frac{g_2 V_1^2}{2} \cos(2\omega_1 t) + \frac{g_2 V_2^2}{2} \cos(2\omega_2 t) + \\
& + g_2 V_1 V_2 \left[ \cos((\omega_2 - \omega_1)t) + \cos((\omega_2 + \omega_1)t) \right] + \\
& + \frac{g_3 V_1^3}{4} \cos(3\omega_1 t) + \frac{g_3 V_2^3}{4} \cos(3\omega_2 t) + \\
& + \frac{3g_3 V_1^2 V_2}{4} \left[ \cos((2\omega_1 + \omega_2)t) + \cos((2\omega_1 - \omega_2)t) \right] + \\
& + \frac{3g_3 V_2^2 V_1}{4} \left[ \cos((2\omega_2 + \omega_1)t) + \cos((2\omega_2 - \omega_1)t) \right]
\end{aligned} \tag{2.12}$$

From (2.12) we can see that new and undesired spectral components have appeared due to the PA nonlinear behavior. In particular it is possible to classify some of these frequency components:

- *Compression* at  $\omega_1 + \omega_1 - \omega_1 = \omega_1$  and  $\omega_2 + \omega_2 - \omega_2 = \omega_2$
- *Capture* at  $\omega_1 + \omega_2 - \omega_2 = \omega_1$  and  $\omega_2 + \omega_1 - \omega_1 = \omega_2$

The *compression* and *capture* frequency components represent the in-band distortion.

- *Harmonic distortion* which can be classified in:
  - $2^{nd}$  order harmonic distortion at  $2\omega_1$  and  $2\omega_2$
  - $3^{rd}$  order harmonic distortion at  $3\omega_1$  and  $3\omega_2$
- *Intermodulation distortion* which can be classified in:
  - $2^{nd}$  order Intermodulation distortion at  $\omega_1 + \omega_2$  and  $\omega_1 - \omega_2$
  - $3^{rd}$  order Intermodulation distortion at  $2\omega_1 + \omega_2$ ,  $2\omega_1 - \omega_2$  and at  $2\omega_2 + \omega_1$ ,  $2\omega_2 - \omega_1$

The harmonic (HD) and intermodulation distortion (IMD) components represent the out-of-band distortion.

Figure 2.3 shows the output spectrum of a nonlinear power amplifier when considering a two-tone test at 2.4 GHz and two tones separation of 20 MHz. The intermodulation distortion (IMD) products shown in Fig. 2.3 are up to seventh order. Since *harmonic distortion* (mainly produced by the even terms of the PA polynomial model) can be easily removed by filtering the unwanted components, the *intermodulation distortion* (mainly produced by the odd terms of

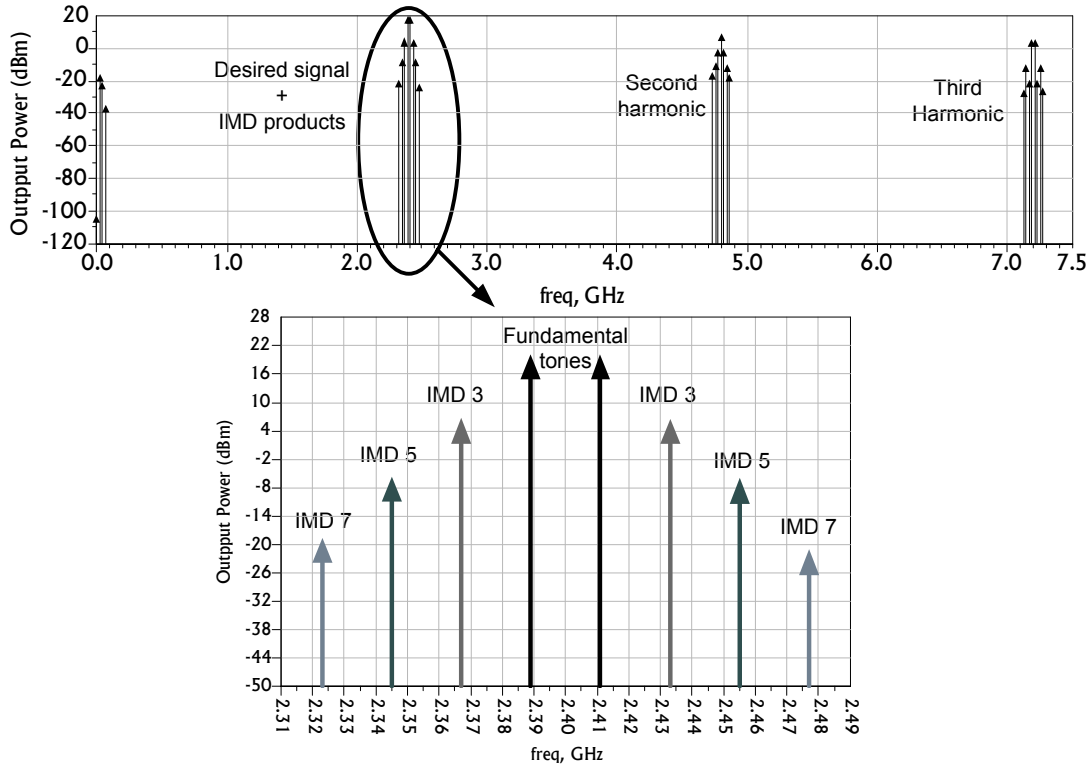

**Figure 2.3:** Power amplifier two-tone test output spectrum.

the PA polynomial model) appears as the most critical issue regarding linearity, because their frequency (intermodulation) components are too close to the desired signals that can not be removed by filtering. Thus the use of *linearizers* is justified because represent a good alternative in order to minimize this unwanted frequency components appearing close to the wanted signals. Since IMD cannot be easily removed by simply filtering, there are several measures aimed at characterizing the level of IMD present in the PA [Pot99, Ken00]. Some of these measures are commonly provided by manufacturers. For example, some useful Figures of Merit (FOMs) that characterize the intermodulation level present in nonlinear power amplification are the *Carrier to Intermodulation ratio* (C/I) or the *third-order Intercept Point* (IP3). The *intercept point* is aimed at quantify the power delivered at fundamental components with respect to the intermodulation products. Note that if we consider the two tones test but with two fundamental tones of the same amplitude ( $V_1 = V_2 = V$ ), from (2.12) it is possible to see how *the third order intermodulation products* ( $\{2f_1 - f_2\}, \{2f_2 - f_1\}$ ) are proportional to  $V^3$ . That means that for each dB the fundamental tone goes up, the *IMD3 products* increase by 3 dB. Therefore, the IP3 is defined as the theoretical level at which the intermodulation products are equal to the fundamental tone. Fig. 2.4 shows how the IP3 is obtained through extrapolating the linear behavior of fundamental (with a slope of 1 dB/dB) and the third IMP (with a slope of 3 dB/dB) and finding the intercept

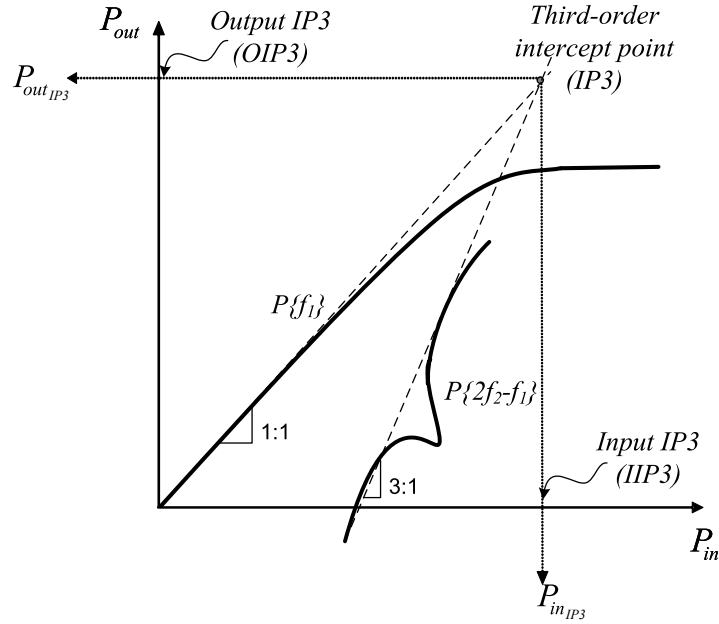

**Figure 2.4:** Definition of a power amplifier third order intercept point.

point.

The  $C/I_3$  or the *IMD3 ratio* can be defined as the ratio of the power of the 3<sup>rd</sup> order intermodulation component to the power of one of the fundamental tones.

$$C/I_3 = \frac{P_{out}\{f_1\}}{P_{out}\{2f_2 - f_1\}} \quad (2.13)$$

Considering a weak nonlinearity, the  $C/I_3$  can be calculated using the IP3 value [Sal05], which is usually provided by the manufacturer in the PA specifications:

$$C/I_3[\text{dBc}] = \text{IMD3}_{ratio}[\text{dBc}] = 2(P_{out}[\text{dBm}] - \text{OIP3}[\text{dBm}]) \quad (2.14)$$

The unwanted effects of higher order intermodulation distortion products can be also considered and measured as well as the harmonic distortion ones. However, they are not here presented for simplicity since third order intermodulation products are the most critical from the linearity performance point of view.

#### 2.1.4 Nonlinearity Measures for Modulated Signals

Despite unmodulated carriers provide useful information of the intermodulation products that appear at some specific discrete frequencies, usually more complex signals (modulated) occupying a continuous band of frequencies are used in communications systems. Thus, a two-tone test



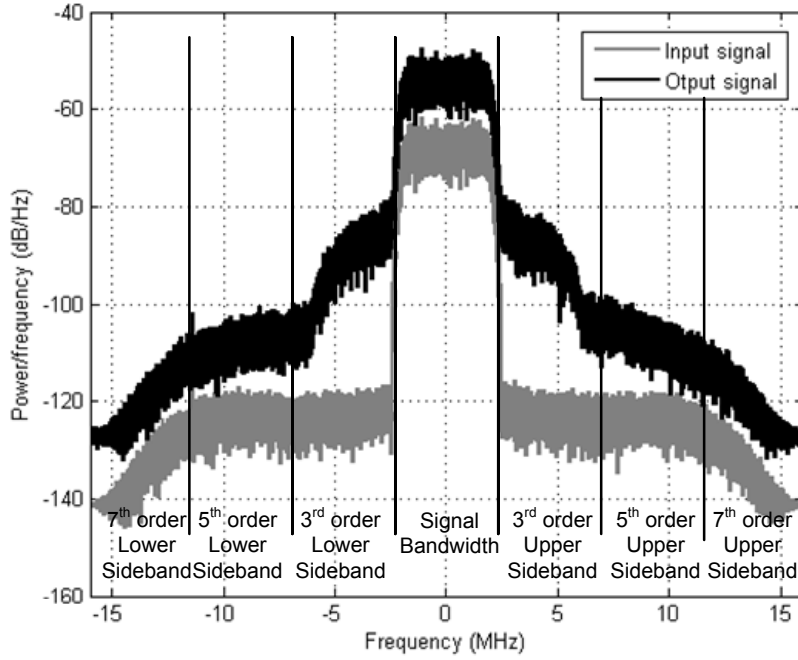
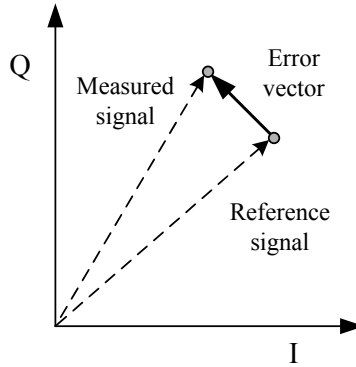

**Figure 2.5:** Input and output spectra of a WCDMA modulated signal.

represents a rough approximation in order to characterize the nonlinear PA behavior. Usually, signals traveling an amplifier are modulated signals characterized by complex frequency spectra. When complex modulation schemes are adopted, nonlinearities appear over a continuous band of frequencies and this is referred as the *spectral regrowth*. Figure 2.5 shows the spectra of both input and amplified output of a WCDMA modulated signal. The output spectrum presents spectral regrowth due to the nonlinear behavior of the PA. In this case a useful figure of merit is the *Adjacent Channel Power Ratio* (ACPR) or also known as the *Adjacent Channel Leakage Power Ratio* (ACLR), defined as the ratio of the total power over the channel bandwidth to the power delivered in the adjacent channels (both upper sideband-US, and lower sideband-LS). That is:

$$ACPR = \frac{P_{in-band}}{P_{adjacent-channel}} = \frac{\int_B P_{out}(f) \cdot df}{\int_{LS} P_{out}(f) \cdot df + \int_{US} P_{out}(f) \cdot df} \quad [dBr] \quad (2.15)$$

The equipment of any communication system must be compliant with the communication standard of any particular technology. Therefore it has to take into account the in-band and out-of-band power emission limit specified in standards in terms of a *spectrum emission mask* and ACLPR. The ACLR specifies the adjacent power level permitted in order to not interfere with the adjacent channels. So then, it is compulsory to avoid high levels of *spectral regrowth*. This objective can be easily attained by operating at a very linear region of the PA, that is, with significant *back-off* (dBs of separation from the PA compression point). This however, as will be explained in the following subsection, will result in very inefficient power amplification, which



**Figure 2.6:** Error Vector representation.

is critical for mobile equipment in a wireless environment.

Let us consider again the modulated input signal in (2.6) and its distorted output signal in (2.7), but this time expressed in its Cartesian form, that is

$$\begin{aligned}
 v_{out}(t) = & \underbrace{G[A(t)] \cos(f(A(t)))}_{\text{In-phase}} \cos[\omega_c t + \varphi(t)] - \\
 & - \underbrace{G[A(t)] \sin(f(A(t)))}_{\text{Quadrature}} \sin[\omega_c t + \varphi(t)]
 \end{aligned} \tag{2.16}$$

where both  $G[\cdot]$  and  $f(\cdot)$  are nonlinear functions distorting the output amplitudes of the original In-phase ( $I\{A(t)\}$ ) and Quadrature ( $Q\{A(t)\}$ ) components [Ken00]. This Cartesian model is constructed from two nonlinear amplitude models.

Nonlinear distortion directly affects *nonconstant envelope signals* presenting linear modulation schemes, that is, schemes that modulate amplitude and phase (or I and Q) together. Therefore digital linear modulations such as *Quadrature Amplitude Modulation* (QAM) can suffer from nonlinear distortion in the amplification process, and this can be measured with the FOM named *Error Vector Magnitude* (EVM). Fig. 2.5 graphically shows the error vector between the desired (reference) signal and the measured signal. The EVM is defined as the square root of the ratio of the mean error vector power to the mean reference power expressed as a percentage (%).

$$EVM = \sqrt{\frac{\frac{1}{N} \sum_1^N (\Delta I^2 + \Delta Q^2)}{S_{\max}^2}} [\%] \tag{2.17}$$

The EVM measure is a FOM that includes information on the transmit filter accuracy, D/A-converter, modulator imbalances, untracked phase noise, and power amplifier non-linearity. In a similar manner to the spectral regrowth limitations, communications standards (e.g. [iee03, ets01, iee04]) determine maximum levels of the EVM permitted at the transmitter antenna and at the receiver, depending on the modulation scheme used and the use (or not) of any codification.

A *Percentage Linearization* (PL) and a *Percentage Linearization Area* (PLA) are proposed in [O'D04a] as two new measures of the degree of AM-to-AM linearization, achieved by a linearization scheme, of the saturating region of nonlinear PAs. The measures are for estimating the general global PA characteristic linearization rather than that of any local nonlinearities encountered along the PA characteristics.

Other FOMs also considered in communications standards (but mainly from the receiver point of view) are the *Symbol Error Rate* (SER) and the *Bit Error Rate* (BER), which provide the percentage of the number of symbols and bits erroneous with respect of the total number of symbols and bits received, respectively. Both error rates are closely related to the undesirable deformation of the constellation points [Cid05] and thus to the value of the EVM.

## 2.2 Trade Off Between Linearity and Efficiency

The power amplifier efficiency in wireless equipment is one of the most critical issues since it is crucial for prolonging battery life. Moreover, in base stations power efficiency is also of significant concern, since it impacts in both prime power usage and cooling requirements [Cri06]. Power amplifiers are typically the most power-hungry components in RF circuits and can represent up to 70% of the total power consumption in a RF subsystem [O'D04b].

The efficiency of an amplifier is a measure of how effectively DC power is converted to RF power, being the common definition expressed as:

$$\eta = \frac{P_{out}}{P_{DC}} [\%] \quad (2.18)$$

But, by just considering the netted power converted into RF power, the measure does not have to consider the already existing RF power that is injected into the power amplifier, so then the power added efficiency (PAE) is defined like:

$$PAE = \frac{P_{out} - P_{in}}{P_{DC}} [\%] \quad (2.19)$$

Modern spectrally efficient wireless systems use multilevel modulation schemes presenting non-constant envelope signals. These modulation schemes produce signals with high *peak-to-average power ratios*. Commonly in PA the *instantaneous efficiency*, defined as the efficiency at one specific output level, is higher at the peak of the output power, that is, when operating near the compression point. Thus, signals with time-varying amplitudes produce time-varying efficiencies. The need to avoid nonlinear effects in the amplification requires the transmission of signals whose peak amplitudes well below the output peak of the amplifier (back-off operation), which degrades the average efficiency [Vuo03]. Nevertheless, the PA efficiency not only depends on the input or output back-off chosen to operate, but also depends on the power transistor operation class. Fig. 2.6 shows some of the most common power amplifier operation classes, which are

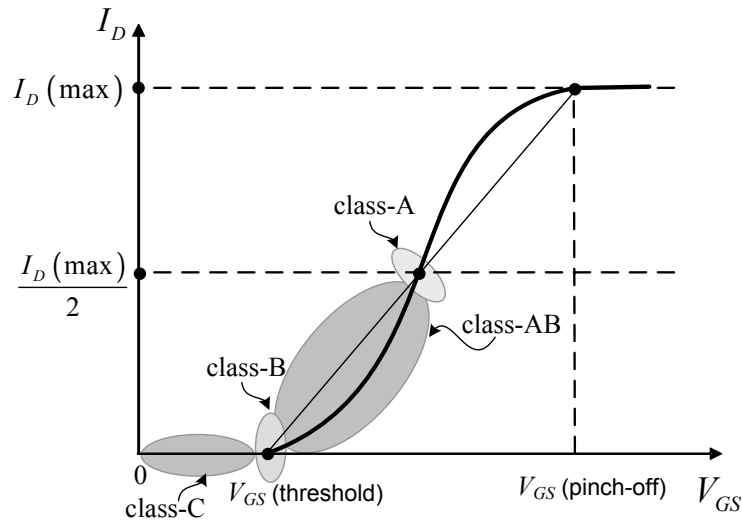

**Figure 2.7:** Power amplifier classes [Sal05].

distinguished by the fraction of the RF cycle over which the power transistor conducts. That means that theoretically, 100% (conduction angle  $2\pi$ ) corresponds to class A, 50% (conduction angle  $\pi$ ) to class B, between 50% and 100% to class AB, and finally less than 50% to classes C, D, E and F. The performance trade-off among the different operation classes includes efficiency, linearity, power gain, signal bandwidth and output power [Raa02]. Fig. 2.7 shows the trade-off existing between linearity and efficiency according to the power transistors operation class.

While in class-A, class AB, class B and class C the transistor behaves as a transconductor, in class D, class E and class F it behaves as a switch, thus achieving high efficiency levels. Although class C, class D, class E and class F power amplifiers show high efficiency, they are often not suitable for linear applications because they introduce spurs and cause critical spectral regrowth that penalizes the adjacent channels. However, by using a suitable linearizing circuit these efficient power amplifiers have been used for modulation schemes requiring linear amplification [Gup01]. Therefore the use of class-A PAs operating backed-off ensures linear amplification of signals presenting significant PAPRs, however it results extremely inefficient. On the other hand, the use of a more efficient class PA (e.g. class AB or class C) implies a consequent lack of linearity that avoids accomplishing adjacent channel leakage restrictions.

At this point it is reasonable to introduce the advantages that can offer the use of linearizers. *Linearisation techniques* incorporated in the PA design or as a part of the amplification subsystem permit improving efficiency, by operating less backed-off or by using a more efficient class of PA, at the time that linearity is maintained.

**Table 2.1:** EFFICIENCY AND LINEARITY VS. PA CLASSES OF OPERATION

Class of operation	Operation Mode	Maximum Efficiency (%)	Linearity
Class A	Current source mode	50	Good
Class AB		Better than class A Worse than class B	Better than class B Worse than class A
Class B		78.5	Moderate
Class C		100	Poor
Class D	Switch mode	100	Poor
Class E		100	Poor
Class F		100	Poor

## 2.3 Power Amplifier Memory Effects

Nonlinear memoryless systems, in general, are only responsible for amplitude distortion rather than phase distortion. Thus if a phase distortion is present this indicates that the system has a certain amount of memory. *Memory effects* in power amplifiers can be described as a dependency of the gain of this nonlinear device on past events, that is, time responses are not instantaneous anymore but will be convolved by the impulse response of the system. These bandwidth dependent nonlinear effects are of significant concern since can degrade the performance of some PA linearization techniques such as *digital predistortion*. Memory effects are responsible for changes in the amplitude and phase of distortion components caused by changes in modulation frequency. Fig. 8 shows the manifestation of these memory effects, responsible for the asymmetry of the IMD products. By considering a low-pass complex envelope behavioral model of a PA, Fig. 2.9 shows the relation between the input and a delayed sample of the input and their effects on the PA output for both memoryless PA (Fig.2.9-a) and PA with memory (Fig. 2.9-b). It is possible to observe in the PA with memory the dependency of the gain on the past samples of the input. Several publications have addressed the memory effects problem, describing their causes, proposing measurement methods and models to characterize them [Bos89, Vuo01, Bou03, Fra04]. Fig. 2.10 shows the schematic of a general PA design and the location of the main sources of memory effects.

In a rough classification it is possible to distinguish two basic types of memory effects [Fra05, Vuo03]:

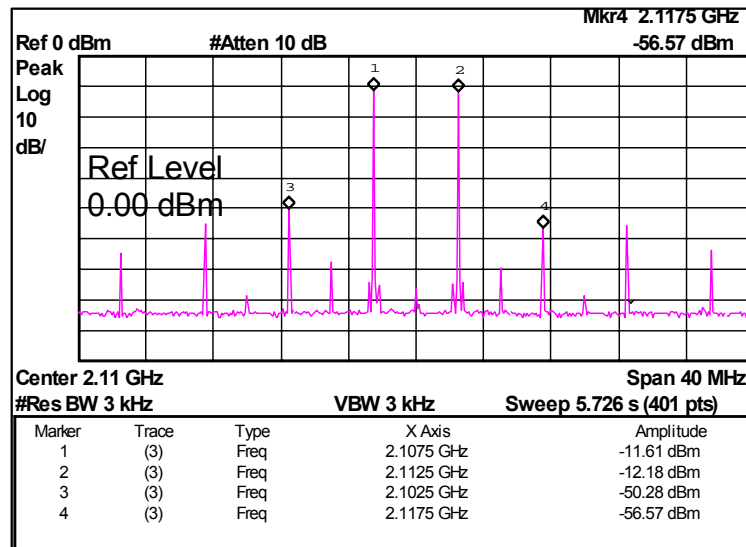

Figure 2.8: Asymmetric IMD products in a solid state amplifier due to memory effects.

- *Electrical memory effects.* These are mainly caused by nonconstant terminal impedances at DC, fundamental and harmonic bands. The most critical ones are due to envelope impedances. If the impedance of the decoupling networks in a power amplifier is high at the envelope frequency of the signal, undesired signals of the same envelope frequency will appear added to the dc supply voltage. These ac signals will cause AM and PM modulations of the RF signal, generating unwanted sidebands with frequencies that fall exactly where the intermodulation distortion products occur.
- *Electrothermal (thermal dispersion) memory effects.* These are caused by dynamic temperature variations at the top of the chip that modifies the electrical properties of the transistor at the envelope frequency. As a result, IMD3 signals that depend on thermal impedance are generated. Typically, thermal memory effects are only of concern for envelope frequencies below 1 MHz because the mass of the semiconductor in the active device cannot change its temperature fast enough in order to keep up with high envelope frequencies.

Despite smooth memory effects are usually not harmful to the linearity of the PA itself; they become a serious issue for the cancellation performance of some linearization techniques. Among the different linearization techniques used for broadband transmitters *digital predistortion* is quite sensitive to memory effects. If the IMD components rotate as function of modulation frequency, for example, but the canceling signals do not, the cancellation performance of the linearization method may be inadequate for wideband signals.

However, even when the cancellation performance in digital predistortion is reduced due to

its sensitiveness to memory effects, a significant amount of improvement in cancellation can be expected by minimizing or canceling memory effects. In order to cancel or minimize memory effects, three techniques have been considered in literature: *Impedance Optimization*, *Envelope Injection* and *Envelope Filtering*.

Impedance optimization and envelope injection both attack the baseband bias impedances seen by the distortion current sources. *Impedance optimization* is based on the optimization of the out-of-band impedances. While, in the *envelope injection* technique, a low-frequency envelope signal is generated and added to the RF carrier. For further details of these two techniques can be found in [Vuo03]. Finally, in the *envelope filtering* technique, the objective is to reproduce the inverse memory effects that are generated inside the PA. Therefore the digital predistorter not only has to compensate the PA nonlinear behavior, but also has to compensate memory effects, which is done by filtering and phase-shifting the envelope signal.

## 2.4 Summary

In this chapter we have shown how nonlinear distortion is an inherent problem of the PA active device. In addition, modern multilevel and multicarrier modulation techniques present high PAPRs. This implies that for having linear amplification and thus being compliant with the communication standards requirements, significant back-off levels are required. Those spectral efficient modulation techniques are also very sensitive to the inter-modulation distortion that results from nonlinearities in the RF transmitter chain. The use of highly linear (class A) PAs operating backed-off penalizes power efficiency which can be critical for base stations and for mobile/wireless users equipment. Moreover coping with high speed envelope signals (presenting significant bandwidths) makes engineers reconsider the degradation suffered from memory effects. Therefore the use of *linearization techniques* to deal with the classic trade-off between linearity and efficiency is a recognized solution that will be developed along this thesis, focusing in our particular contribution to the *digital predistortion linearization*.

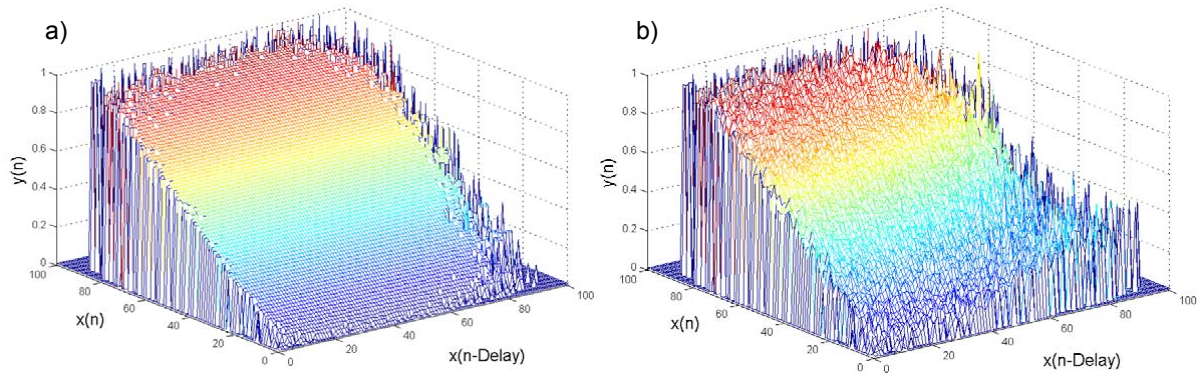

Figure 2.9: a) Memoryless PA; b) PA with memory.

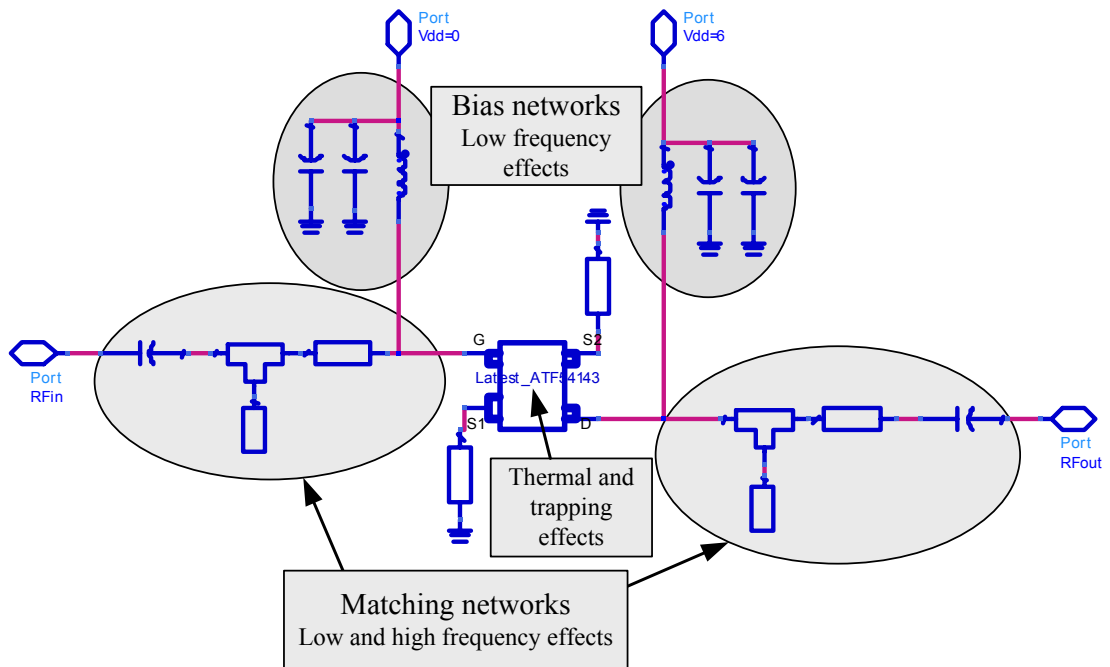

Figure 2.10: Main sources of memory effects in a power amplifier.



