

SAMPLING IN-PHASE AND QUADRATURE COMPONENTS OF BAND-PASS SIGNALS†

José B. MARIÑO and Enrique MASGRAU

Dpto. Teoría de la Señal y Comunicaciones, E.T.S.I. Telecomunicación, Apdo, 30.002, 08080 Barcelona, Spain

Received 2 March 1989

Revised 15 November 1989

Abstract. A filtering method for sampling the lowpass equivalent of a bandpass analog signal is introduced. This input is sampled at exactly twice the sampling rate of the in-phase and quadrature components provided at the output. The sampling frequency determination and the lowpass decimator filter design are straightforward. The practical implementation of the sampling method is accomplished by the polyphase realization of the filter; this implementation is particularly suitable for linear phase FIR designs.

Zusammenfassung. Ein Filterverfahren zur Abtastung des Tiefpaß-Äquivalents eines analogen Bandpaßsignals wird vorgestellt. Das Eingangssignal wird mit dem Zweifachen desjenigen Abtasttaktes abgetastet, den am Ausgang jeweils die Normal- und die Quadraturkomponenten aufweisen. Die Festlegung der Abtastrate und des Tiefpaßfilters vor der Unterabtastung gelingt auf einfache Weise. Die praktische Realisierung des Verfahrens benutzt eine Polyphasen-Struktur und ist daher besonders für den Einsatz linearphasiger FIR-Filter geeignet.

Résumé. Une méthode de filtrage pour l'échantillonnage de l'équivalent passe-bas d'un signal analogique passe-bande est introduite. L'entrée est échantillonnée exactement au double de la cadence d'échantillonnage des composantes en phase et en quadrature délivrées à la sortie. La détermination de la fréquence d'échantillonnage et l'élaboration du filtre décimateur passe-bas est très simple. L'implantation pratique de la méthode d'échantillonnage est obtenue par la réalisation polyphase du filtre. Elle est particulièrement adaptée pour l'élaboration de filtres RIF à phase linéaire.

Keywords. Sampling, band-pass signals, complex-envelope, in-phase and quadrature components.

1. Introduction

In many applications where bandpass signals are involved, it is useful to process the signal in lowpass form. Modulation, demodulation and detection systems are typical examples. Let us consider the bandpass signal $s_a(t)$, whose spectrum $S_a(j\omega)$ is nonzero only for $\omega_1 \leq |\omega| \leq \omega_2$. This signal can be represented by its lowpass equivalent $e(t)$, defined as

$$e(t) = h_{lp}(t) * s_a(t) e^{-j\omega_0 t}, \quad (1)$$

where $h_{lp}(t)$ is a lowpass filter to remove the signal

alias centred at $-2\omega_0$, $\omega_0 = \frac{1}{2}(\omega_1 + \omega_2)$ is the centre frequency of $s_a(t)$, and $*$ denotes linear convolution. The lowpass equivalent is a complex signal, whose real and imaginary parts constitute the in-phase $i(t)$ and quadrature $q(t)$ components of $s_a(t)$, respectively,

$$e(t) = i(t) - jq(t). \quad (2)$$

This approach has been extended to the digital processing domain. Sampling of $i(t)$ and $q(t)$ provides a convenient digital representation of $s_a(t)$. Relations (1) and (2) suggest the conventional method to obtain the sequences $i(n)$ and $q(n)$, sampled versions of in-phase and quadrature components. The corresponding scheme is depicted in

† This work was supported by ENSA under contract TC-500.

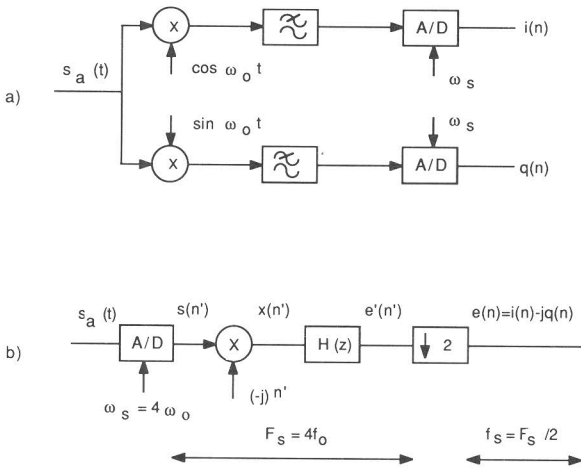

Fig. 1. Conventional (a) and theoretical framework of introduced method (b) for sampling in-phase and quadrature components.

Fig. 1(a). As is well-known, the signal $s_a(t)$ is processed by two independent channels, whose outputs are the sequences $i(n)$ and $q(n)$. This two-channel configuration has two main drawbacks: (a) it needs two analog-to-digital converters and (b) the frequency responses of both channels require close matching in amplitude and phase for proper operation.

In [2] it was shown that both disadvantages can be overcome by sampling the analog band pass signal $s_a(t)$ at four times its centre frequency ω_0 . Following this suggestion, in [3] a simple method for sampling in-phase and quadrature components was introduced. The present paper describes an alternative configuration with a more straightforward design and easier implementation.

2. Outline of component sampling method

Figure 1(b) shows the block diagram of the theoretical framework for the sampling method introduced in this paper and Fig. 2 illustrates its operation principle by means of the spectra of the different sequences involved in this block diagram. Initially, the analog signal is assumed to be sampled at a sampling frequency $F_s = 4f_0$. The

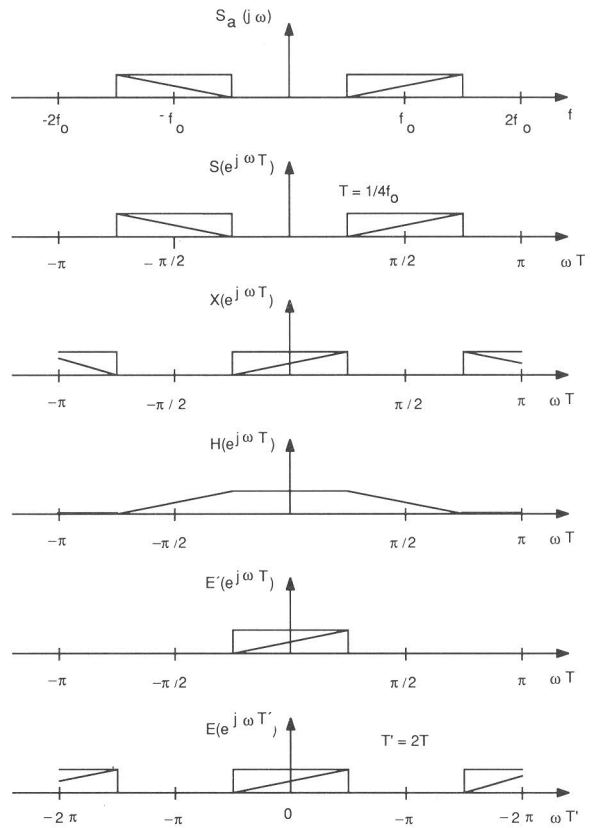

Fig. 2. Spectra of the signal and the different sequences in scheme in Fig. 1(b).

corresponding sequence $s(n')$ is modulated in order to move down the signal band and center it at zero frequency. The resulting complex sequence $x(n')$ is filtered by $H(z)$, that eliminates the unwanted alias of $X(e^{j\omega T})$ and provides the low-pass equivalent $e'(n')$ of $s(n')$. Finally, $e'(n')$ is decimated by a ratio $R = 2$, resulting in the sequence $e(n)$, that represents the desired low-pass equivalent.

Since the stopband attenuation of $H(z)$ is not infinite, after decimating, the residual spectral components of the unwanted alias of $X(e^{j\omega T})$ are mixed on the lowpass components. Therefore, the negative frequency components of $e'(n')$ are contaminated with the attenuated positive frequency components, and vice versa. The effect on the bandpass signal is that the frequencies below f_0

are corrupted with an attenuated replica of the spectral components above f_0 , and vice versa. This nonlinear effect is equivalent to the distortion produced by a mismatch between the in-phase and quadrature channels of the conventional approach. However, since it is easier to control the stopband attenuation of a digital filter than to achieve a perfect balance between the passbands of two analog filters, the approach described in this paper allows a more exact sampled representation of a real bandpass signal.

It is worth mentioning that the decimation ratio between $e'(n')$ and $e(n)$ must be greater than or equal to 2 and it is limited depending on the relation between the centre frequency f_0 and the signal bandwidth; in our case, this ratio is selected $R = 2$ for reasons to be explained later. Thus, while the analog signal is sampled at the rate $F_s = 4f_0$, the low-pass equivalent will be provided at the sampling frequency $f_s = \frac{1}{2}F_s$.

3. Practical sampling frequency selection

In many practical situations the centre frequency f_0 is much higher than the signal bandwidth. Thus, the sampling frequency $F_s = 4f_0$ is clearly an inadequate choice. There are two ways of solving this problem: (a) mix down the analog signal and (b) sub-sample $s_a(t)$. In fact, both processes should be incorporated in an actual design.

The mix-down operation is well-known. However, as far as the sub-sampling processing is concerned, the selection of the sampling frequency must be considered carefully. Figure 3(a) illustrates the spectrum of the analog signal. The following notation is used:

- Bfs = bandwidth of the useful analog signal,
- Bff = stop-band bandwidth of the anti-aliasing analog filter.

The spectrum region covered by the anti-aliasing filter bandwidth but not including the signal band is not necessarily noise free (for instance, in a radio

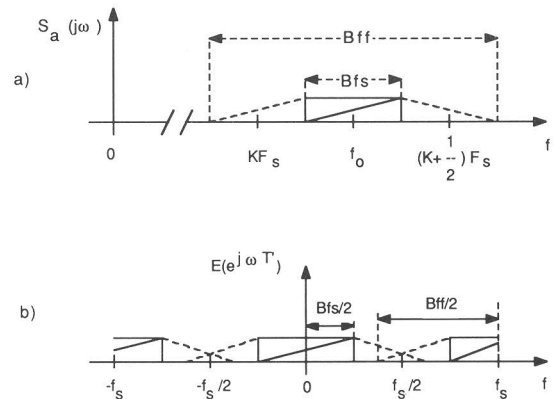

Fig. 3. Nomenclature used to determine the sampling frequency: (a) spectrum of the analog signal $s_a(t)$; (b) spectrum of the low-pass equivalent sequence $e(n)$.

receiver), and as a consequence can contaminate the signal as the subsampling is accomplished. Figure 3(b) shows the spectrum of the low-pass equivalent sequence $e(n)$, when sampled at the f_s rate. It is easy to see that the signal remains undistorted if the sampling frequency f_s verifies

$$f_s \geq \frac{1}{2}(Bfs + Bff).$$

In terms of F_s , this condition becomes

$$F_s \geq \frac{1}{2}R(Bfs + Bff), \tag{3a}$$

where R is the decimation ratio between $e'(n')$ and $e(n)$. Because our interest is to have F_s as low as possible, $R = 2$ has been chosen. Hence (3a) reduces to

$$F_s \geq Bfs + Bff. \tag{3b}$$

Additionally, since the sub-sampling operation has to provide a signal band centered at $\frac{1}{4}F_s$ (a fact that is the basis of our design), the center frequency f_0 must be related to the sampling frequency F_s by means of the expression

$$f_0 = \frac{1}{4}F_s + KF_s$$

or, equivalently,

$$F_s = 4f_0 / (4K + 1), \tag{4}$$

with K being an integer.

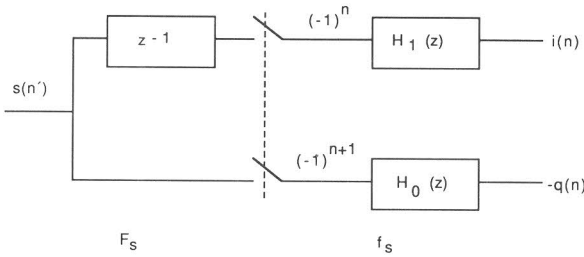

Figure 4. Practical implementation of in-phase and quadrature component sampling, where $H_0(z)$ and $H_1(z)$ were defined in (5).

Thus, F_s may be chosen as the lowest frequency defined by relation (4) that verifies condition (3b).¹

4. Practical implementation of component sampling system

Figure 4 shows the practical implementation of the theoretical diagram in Fig. 1(b). This realization stems from the following rationale. Let us define the sequences

$$s_i(n) = s(2n + i), \quad i = 0, 1,$$

in such a way that $s_0(n)$ and $s_1(n)$ include the even and odd samples of $s(n')$, respectively. The Z-transform $S(z)$ of $s(n')$ can be expressed by

$$S(z) = \sum_{i=0}^1 z^{-i} S_i(z^2),$$

where $S_i(z)$ is the Z-transform of $s_i(n)$. Thus, the Z-transform of the modulated sequence $x(n')$ is

$$X(z) = S(jz) = \sum_{i=0}^1 g(i) z^{-i} S_i(-z^2),$$

where

$$g(i) = (j)^{-i}.$$

By using the polyphase form [1] for the filter transfer function $H(z)$,

$$H(z) = \sum_{k=0}^1 z^{-k} H_k(z^2), \quad (5)$$

¹ As a matter of fact, f_0 may be also moved down to $-\frac{1}{4}F_s$ by subsampling with $F_s = 4f_0/(4K - 1)$. In this case, $s(n')$ must be modulated by $(j)^n$ in Fig. 1(b). In order to minimize F_s , both alternatives should be considered.

we obtain the Z-transform of the filter output

$$E'(z) = \sum_{i=0}^1 g(i) \sum_{k=0}^1 z^{-k-i} H_k(z^2) S_i(-z^2).$$

According to our theoretical framework, if we down-sample $e'(n')$ by a decimation ratio of 2, we get the low-pass equivalent $e(n)$ sampled at a rate f_s . It is not difficult to prove that

$$P(z) = \sum_{i=0}^1 g(i) z^{-1} H_{1-i}(z^2) S_i(-z^2)$$

is the Z-transform of the sequence

$$p(n') = \begin{cases} 0, & n' = 2n, \\ e'(n'), & n' = 2n + 1. \end{cases}$$

Thus, if we define the lowpass equivalent $e(n)$ as

$$e(n) = p(2n + 1),$$

its Z-transform

$$E(z) = \sum_{i=0}^1 g(i) H_{1-i}(z) S_i(-z)$$

leads to the filter configuration of Fig. 4.

This implementation is particularly advantageous when $H(z)$ is a finite impulse response filter with linear phase and odd impulse response length L ,

$$L = 2N - 1.$$

In such a case, the impulse response $h(n)$ satisfies

$$h(n) = h(L - 1 - n). \quad (6)$$

According to the polyphase decomposition (5), the impulse response $h_k(n)$ of every subfilter $H_k(z)$ is defined by

$$h_k(n) = h(k + 2n), \quad k = 0, 1, \quad (7)$$

with the respective lengths being

$$L_0 = N, \quad L_1 = N - 1.$$

From (6) and (7), it is easy to establish that the subfilters $H_k(z)$ also have a linear phase, i.e., their impulse responses verify

$$h_k(n) = h_k(L_k - 1 - n).$$

5. Example

Let us consider the IF signal of a HF receiver. This signal is centered at 455 kHz with bandwidth $Bfs = 10$ kHz and filtered by an anti-aliasing filter with bandwidth $Bff = 30$ kHz at 80 dB. The decimation filter $H(z)$ requires having a maximum pass-band attenuation $\alpha_p = 0.5$ dB and a minimum stop-band attenuation $\alpha_a = 80$ dB.

From (3b) and (4) we obtain

$$F_s = 40.\bar{4} \text{ kHz},$$

with $K = 11$. The specifications for filter $H(z)$ are

$$\alpha \leq \alpha_p = 0.5 \text{ dB} \quad \text{for} \quad |f| \leq f_p = \frac{1}{2}Bfs \\ = 5 \text{ kHz},$$

$$\alpha \geq \alpha_a = 80 \text{ dB} \quad \text{for} \quad |f| \geq f_a = \frac{1}{2}(F_s - Bfs) \\ = 15.\bar{2} \text{ kHz}.$$

These requirements are met by a linear phase FIR filter with an impulse response length $L = 13$.

6. Conclusions

A simple method for sampling in-phase and quadrature components of an analog bandpass

signal has been introduced. The main features of the method are

- (a) Each sequence is obtained by filtering a sub-sequence of the sampled bandpass signal.
- (b) The non-linear distortion introduced in the spectrum of the bandpass signal by the in-phase and quadrature representation is governed by the stopband attenuation of a decimating filter.
- (c) The analog signal is sampled at just twice the final sampling rate.
- (d) The sampling frequency determination and the filter design are straightforward.

References

- [1] M.G. Bellanger et al., "Digital filtering by polyphase network: Application to sample rate alteration and filter banks", *IEEE Trans. Acoust. Speech Signal Process.*, Vol. ASSP-24, No. 2, April 1976, pp. 109-114.
- [2] V. Considine, "Digital complex sampling", *Electronics Letters*, Vol. 19, No. 16, 4 August, 1983, pp. 608-609.
- [3] C.M. Rader, "A simple method for sampling in-phase and quadrature components". *IEEE Trans. Aerospace Electron. Systems*, Vol. AES-20, No. 6, November 1984, pp. 821-824.