

Data communication and control systems implementation in the OBSEA

Carola Artero¹, Marc Nogueras¹, Juanjo Dañobeitia², Antoni Mànuel¹

(1) SARTI (Remote Acquisition and Data Processing Systems), UPC (Technical University of Catalonia)
Rambla de l'Exposició, 24, Ed. VG5, 08800 Vilanova i la Geltrú (Barcelona) SPAIN.

Tel.:(+34) 938 967 200 eMail: carola.artero@upc.edu

(2) Unidad de Tecnología Marina (UTM), CSIC, Paseo Marítimo de la Barceloneta, 37-49, 08003, Barcelona, Spain

Abstract – In this paper is described the system that controls the connected devices in a subsea observatory. The control system is constantly monitoring the internal and external components of the observatory detecting operating faults and acting automatically in consequence.

Keywords

OBSEA, control system, SNMP, underwater communications

1. INTRODUCTION

More and more, needs for higher resolution, volume of information and longer data series are increasing in the oceanographic observation. In some applications, traditional observation systems such as autonomous oceanographic buoys and measures taken from oceanographic ships present serious disadvantages respect costs, volume of data delay of data or autonomy of the batteries. The new cabled underwater observatories can be modular, flexible and can be adapted to different uses and requirements to satisfy the requirements of the scientific community. The OBSEA [1] project (Expandable Seafloor Observatory) is a collaborative task, between CSIC (Consejo Superior de Investigaciones Científicas) [2] and UPC (Universitat Politècnica de Catalunya) [3], to design and develop a seafloor observatory placed in front of the Vilanova i la Geltrú (Spain) coast. The OBSEA structure consists in two stations: the Shore Station and the Subsea Station. The management servers in charge of status

monitoring and data recollection are placed in the Shore Station. In the Subsea Station are all the oceanographic instruments and related electronics for its power supply, communications and control. The data servers at Shore are continually storing the information and providing the interface toward the world, giving controlled access to the scientific community.

2. SYSTEM DESCRIPTION

Shore Station

As can be seen in figure 1, Shore Station is composed by the management servers, that are monitoring and controlling the status of all elements in the system, the data servers, which are storing and serving the acquired information, the communications system, which transmits the information through the submarine optical fiber, and the power system in charge of providing the necessary electrical power to the submerged elements.

The power system, is equipped with a cluster of AC/DC converters producing up to 320Vdc and 11Amps. The communication system is the Ethernet network of switches and optical fiber necessary to transmit data to the Marine Station. Finally, the control system contains the servers with the management and data storage software, which monitors and controls the connected devices.

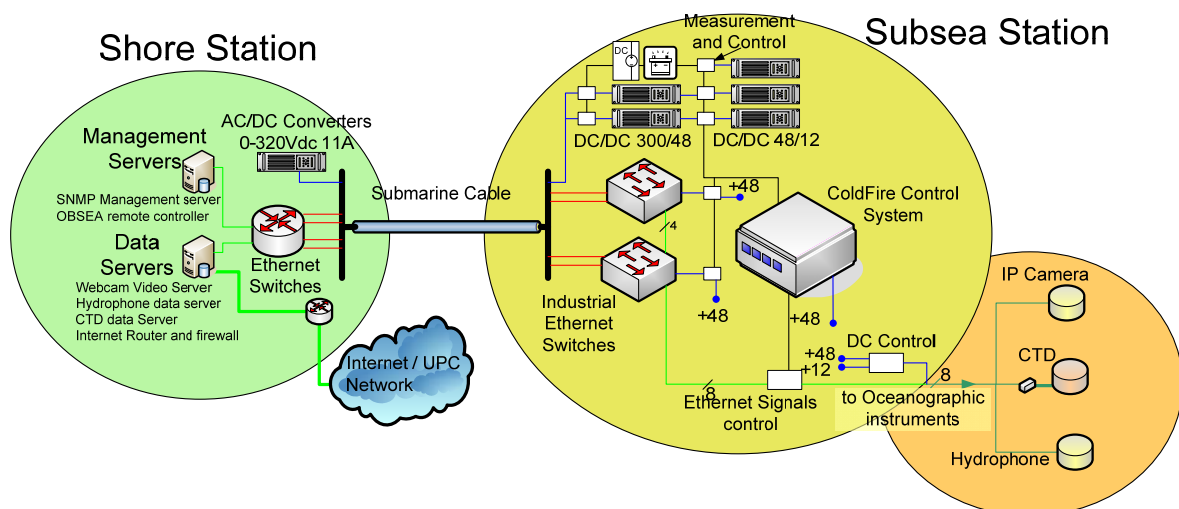

Figure 1 General diagram

Subsea Station

The Subsea Station is the point where are connected the different oceanographic instruments types according to the needs of our scientists, such as seismometer, CTD (Conductivity Temperature Depth), sensors for measurement speed, turbidity or existing amount of chlorophyll in the water. The Subsea Station will be in charge to supply the energy to the instruments, transmit its data to ground, control the status of all elements, and transmit it to the control server.

Likewise, the Subsea Station consists of the same three systems that Shore Station power, communication, and control systems:

Power System formed by the emergency batteries and 5 switching converters: 2 of 300/48V and 3 of 48/12V.

Communications system: Formed by two industrial Ethernet switches in charge of the optical interface towards the submarine cable and simultaneously the connection of the signals of the sensors and control system.

The submarine control system is composed by a platform from Dycce[4] that integrates a microcontroller of 32 bits ColdFire MCF5282[5]. This unit has the necessary functions to implement SNMP protocol (Management Protocol). This device monitors and controls the energy system, atmosphere and electric parameters, as well as performs the connection control of external instruments, and ensures the right running of subsea observatory.

In figure 1, we can see a scheme of general configuration of the station.

Control system of the subsea station

The control system is the one in charge of the supervision and control of several environmental and electrical parameters to maintain the correct operation of the subsea observatory. The system accepts commands and generates alerts using SNMP protocol and alternatively through a console RS232 communication for emergency operations.

In order to develop the control algorithm of the Subsea Observatory is necessary to obtain data from different measurement devices. For this reason, two peripheral from "National Control devices" have been included in the system: AD1232PROXR and XR16xDPDT [7]. The first one contains analogical to digital converters, which samples and quantifies the incoming signals from measurement devices. The second element contains relay drivers to control all the devices. The communication with these boards is performed through one serial RS232port, as is shown in Figure 2.

SNMP Control system

SNMP[8] is a standard protocol commonly used in networking. It is part of the TCP/IP family protocols and allows the system administrators to supervise a network

function, as well as to look for and to solve the possible problems. Two types of elements shape the protocol, an agent and a manager. In our case the agent is running in the control system of Subsea Station to manage and monitor the node, but all the other network elements also have its native SNMP agent. The manager is the software that is executed in the Shore Station, which is entrusted to monitor the network; his task consists of consulting the different agents which are in the nodes.

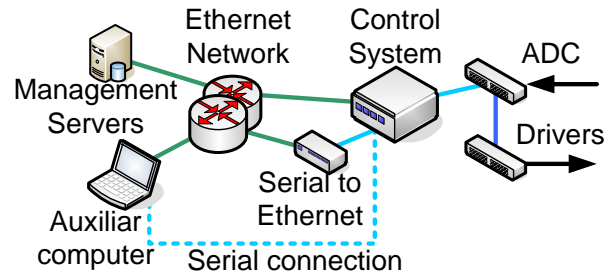

Figure 2 Diagram of the subsea control system

Control algorithm

The internal algorithm of the control system is in charge of these actions:

- To feed and control the operation of the oceanographic instruments connected to the Subsea Station.
- To assure that not used connectors are always free of voltage.
- To establish the connection/disconnection of instruments in water.
- To avoid that an external instrument can affect the internal operation of station.
- To monitor internal atmosphere for thermal control and leakage detection.
- To monitor and control all internal components.

3. OBTAINED RESULTS

The observatory OBSEA was commissioned on May 19th of 2009 with 3 oceanographic instruments (CTD, hydrophone and submarine camera). From that moment it is completely operative and working correctly. But before, some laboratory tests were executed consisting of behavior simulation of the Subsea Station elements using an Iberco [9] 20 bar hyperbaric chamber. First tests were executed to verify the used materials resistance and watertightness of the equipment infrastructure. In figure 3 as can be seen one of the hyperbaric chamber tests. Another set of tests has been done also to verify all the electronic components individually and connected together obtaining by this way optimal configurations for communications equipment, adjusts of power supplies and calibration coefficients for analog to digital converters. A high stress test has been done also to certify that control software is stable under all the possible conditions and situations.

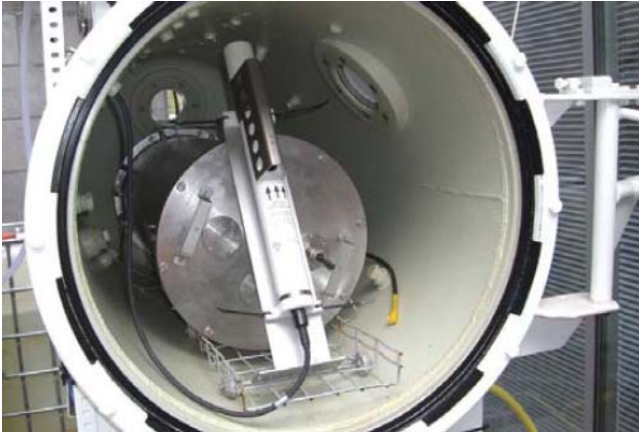

Figure 3 Hyperbaric chamber

4. CONCLUSIONS

In the submarine observatories the system of data-acquisition and control is one of the fundamental parts. In this way, parameters and variables needed by the scientist are retrieved with this acquisition system

The control system entrust at any moment that the Subsea Station works correctly. Before failure or wrong operation from the observatory elements, the control system acts sending alarms to the Ground station.

Thanks to OBSEA project is possible to obtain all data and variables from different sensors types through SNMP and have them monitored at any moment. This monitoring must be friendly for the technician who is supervising the connected devices operation of the stations. At present OBSEA project is working perfectly and in the future is expected to increase the number of underwater nodes.

For more information visit <http://www.cdsarti.org> or <http://www.obsea.es>.

ACKNOWLEDGMENT

The project OBSEA is being founded from the Spanish Ministry of Education and Science (MEC) with the projects “Interoperabilidad en redes de sensores marinos y ambientales” CTM2008-04517/MAR and “Prototipo preliminar de Observatorio Submarino Expandible Cableado” EMSO CAC-2007-09. The authors acknowledge the support of the Telefonica representatives Jorge Rubio, Isabel Alcober and Francisco Fernandez Veigas, also to Mariano Santos from Tyco Marine, and Lluís Sales from Prysmian Cables y Sistemas.

REFERENCES

- [1] OBSEA, <http://www.obsea.es>
- [2] CISC, <http://www.csic.es>
- [3] UPC, <http://www.upc.es/>
- [4] DYCEC, <http://www.dycec.com/>
- [5] Motorola, “MCF5282 ColdFire Microcontroller User's Manual”, Rev.2 1/2004.
- [6] 68K/ColdFire, www.freescale.com/coldfire
- [7] National Control Devices, LLC “ProXR Series. RS-232 E3C Networkable Relay Controllers” <http://controlanything.com/>
- [8] Stallings, William (1999). “SNMP, SNMPv2, SNMPv3, and RMON 1 And 2”. Addison-Wesley, ISBN 0201485346.
- [9] Iberco- Cámaras Hiperbáricas e Ingeniería, <http://www.iberco.es/>
- [10] M. Nogueras, J. Santamaria, A. Mánuel, “Construction of the OBSEA Cabled Submarine Observatory” Instrumentation Viewpoint, Num.6, pp33-34, autumn 2007.
- [11] C. Artero, M. Nogueras, S. Shariat-Panahi, A. Mánuel, et al.. “Diseño del sistema de control y adquisición de datos del Observatorio Submarino ExpAndible (OBSEA)”. SAAEI08. Cartagena (España). Septiembre 9-11 de 2008.