

A NEW ALGORITHM FOR ADAPTIVE IIR FILTERING BASED ON THE LOG-AREA-RATIO PARAMETERS

José A. Rodríguez-Fonollosa, Enrique Masgrau

Departament de Teoria del Senyal i Comunicacions
 Universitat Politècnica de Catalunya
 Apdo. 30.002, 08080 Barcelona, Spain.

Log-area ratios have been traditionally used in speech processing applications because, in the autoregressive model, the spectral sensitivity curves are almost flat for these parameters, and this property make them useful to quantize the LPC coefficients and in the definition of spectral distances. In this communication it is shown that this almost flat spectral sensitivity it is also an interesting property in adaptive IIR filtering. A new IIR lattice-form algorithm is proposed in which the update equation is applied to these parameters instead of the reflection coefficients. This transformation gives a more uniform performance surface with no unstability region and, as a result, the behavior of the gradient search methods is clearly improved.

1. INTRODUCTION

To date, the majority of adaptive filtering problems have been solved with finite-impulse-response (FIR) filters because they are well behaved, i.e., they are unconditionally stable and their error surface is unimodal. However, infinite-impulse-response (IIR) filters present some advantages over FIR filters and it is anticipated that the adaptive IIR filter will replace the widely-used adaptive FIR filter in many applications.

Adaptive IIR filtering has been an active area of research over the last several years and it is also closely related to the problem of recursive parameter estimation. Nevertheless several problems still remain unsolved because the analysis involves highly nonlinear systems. Unlike adaptive FIR filtering, the error surfaces for adaptive IIR filters based on the output error formulation [1] may have some local minima. Their convergence properties are also difficult to study and computer simulations are usually necessary to compare the performance of different algorithms.

In adaptive FIR filtering the performance or error surface, (excess squared error), is a quadratic function with respect to the coefficients and gradient techniques perform well because there is a linear relation between the coefficients vector error and the gradient. However, in adaptive IIR filtering the error surfaces are very different and the slow rate of convergence which is characteristic of this class of adaptive algorithms is in part due to this nonuniform

performance surface. Another drawback associated with the IIR filters is that they may become unstable during adaptation and it is usually necessary to include a stability test. The proposed algorithm has been derived with the aim of solving or reducing these two problems.

2. IIR LATTICE FORM

The adaptive IIR lattice filter (Fig. 1) consists of a feedback lattice structure characterized by the reflection coefficients $\{k_i(n)\}$ and a feedforward structure characterized by the coefficients $\{v_i(n)\}$ [1]. Its primary advantage is that stability monitoring is easy to perform, requiring only that each reflection coefficient satisfy $|k_i(n)| < 1$.

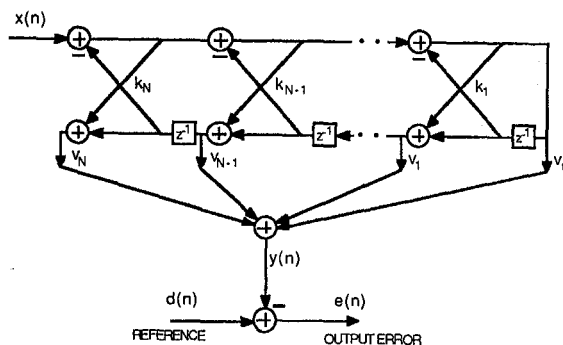

Figure 1. IIR lattice filter

The forward and backward residuals of each stage are calculated as

$$\begin{aligned} f_N(n) &= x(n) \\ f_{i-1}(n) &= f_i(n) - k_i(n)b_{i-1}(n-1) \\ b_i(n) &= b_{i-1}(n-1) + k_i(n)f_{i-1}(n) \quad i=N..1 \\ b_0(n) &= f_0(n)(1) \end{aligned}$$

where $x(n)$ is the filter input.

Then the output $y(n)$ is obtained as the sum of the backward residuals weighted by the feedforward coefficients

$$y(n) = \sum_{i=0}^N b_i(n)v_i(n) \quad (2)$$

The lattice implementation need more computations than the direct form but it has better limited precision properties. The direct form is very sensitive to finite-precision effects so other realizations are usually preferred in fixed filter implementations. In adaptive applications these alternative realizations has been somewhat overlooked because of the simplicity of the direct form but it has been shown recently that structures as the parallel, cascade, and lattice can be useful to overcome the limited precision sensitivity and they offer more simple stability monitoring.

3. ADAPTIVE IIR ALGORITHMS

Most of the adaptive algorithms are gradient-based methods, i.e., algorithms designed to minimize at each instant of time a cost function. These methods perform well when there is a linear relation between the coefficients vector error and the gradient as in FIR filtering.

Nevertheless, in adaptive IIR filtering, this kind of algorithms usually have convergence and stability problems. One of the reasons of these problems is that the gradient tends to infinite when the coefficients are close to the instability region [2]. In the IIR lattice filter is easy to know how far we are from this instability region and in [2] a correction term was derived to reduce the absolute value of the gradient used by the adaptive algorithm as the coefficients get close to the limits of the stability region. The result was a significant improvement in both convergence and robustness of the IIR steepest descent algorithms.

In the work that we present here we have followed another approach in which the performance surface of the adaptive algorithm is modified by a coefficient transformation based on spectral sensitivity. In [3] it is shown that in the all-pole model the sensitivity curves are almost flat for the logarithms of the ratios of area (log-area-ratios). Therefore, it is expected that if we express the mean squared output error as a function of the log-area ratios instead of the reflection coefficients, the error surface will be closer to the desired quadratic shape. Another advantage of this transformation is that now there is no instability region.

All of the adaptive IIR algorithms we have considered have the following form

$$\theta(n+1) = \theta(n) - \mu H^{-1}(n) \psi(n) e(n) \quad (3)$$

where $\theta(n)$ is the coefficient vector

$$\theta(n) = [l_1(n), \dots, l_N(n), v_0(n), \dots, v_N(n)] \quad (4)$$

and $e(n)$ the output error.

$\psi(n)$ is the gradient vector formed with the the derivative of the output of the adaptive filter $y(n)$ with respect to the coefficients

$$\psi(n) = \left[\frac{\partial y(n)}{\partial l_1(n)}, \dots, \frac{\partial y(n)}{\partial l_N(n)}, \frac{\partial y(n)}{\partial v_1(n)}, \dots, \frac{\partial y(n)}{\partial v_N(n)} \right] \quad (5)$$

The complexity of the gradient has always been pointed as the major disadvantage of the lattice realization, because it was assumed that it required order N^2 computations, while in the direct form only order N computations are necessary. Nevertheless, our current work indicates that, in the lattice form, it is also possible to compute the gradient with order N computations without introducing any approximation [8]. In [6] a simplified algorithm with a complexity of order N was also derived but it was based on a approximation that caused convergence problems.

Other terms in (3) are the scalar step size μ that controls the convergence rate and H^{-1} that is an estimate of the inverse Hessian matrix. In a previous paper [7], we studied the performance of the proposed algorithm when a full estimate of this matrix was used to improve the convergence rate. Nevertheless, this estimation increases considerably the computational complexity and, in this paper, we consider the use of simplified diagonal matrix [4]. The diagonal Hessian requires

only
usin
are
abo
give
cost

In a
siml
ada
the
not
qua
less
mat

4. I

In th
wer
prop
by th

The
refle

In th
resp

x(n)

only order N computations, while, in the case of using the full Hessian matrix, order N^2 computations are required. This fact, in combination with the above mentioned simplified gradient computation, gives an algorithm with a reasonable computational cost.

In adaptive FIR filtering the Hessian matrix, or its simplified versions, depend only on the data, but in adaptive IIR filtering, it is time-varying even when the data is stationary because the error surface is not quadratic. Again, a error surface close to the quadratic shape is expected to be useful to obtain a less time-varying and better estimated Hessian matrix.

4. LAR-DH ALGORITHM

In the algorithms studied in [4] the parameters $l_i(n)$ were the reflection coefficients $k_i(n)$ while in the proposed algorithm these coefficients are replaced by the log-area-ratio parameters (LAR).

The log-area-ratios l_i are calculated from the reflection coefficients k_i as

$$l_i = \ln \frac{1-k_i}{1+k_i} \quad (7)$$

In the gradient vector the derivative of $y(n)$ with respect to the log-area-ratio is calculated now as

$$\begin{aligned} \frac{\partial y(n)}{\partial l_i(n)} &= \frac{\partial y(n)}{\partial k_i(n)} \frac{\partial k_i(n)}{\partial l_i(n)} \\ &= \frac{\partial y(n)}{\partial k_i(n)} \left\{ -\frac{1}{2} (1-k_i(n)^2) \right\}, \quad i=1 \dots N \end{aligned} \quad (8)$$

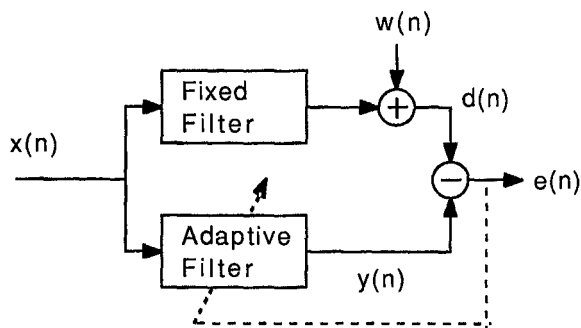

Figure 2. System Identification Configuration

Then, after updating the log-area-ratio parameters with a simplified version of equation (3), (Diagonal Hessian), the reflection coefficients must be computed to be used by the adaptive IIR lattice filter.

$$k_i = \frac{1-e^{l_i}}{1+e^{l_i}}, \quad i=1 \dots N \quad (9)$$

In a real-time implementation the above equation can be simplified and/or stored in a table to reduce more the computation cost.

5. COMPUTER SIMULATIONS

We have performed several computer simulations in a system identification configuration (Fig. 2) to compare the convergence properties of the proposed algorithm (LAR-DH) with the previous diagonal Hessian algorithm (K-DH) described in [4]. Figure 3 illustrates the mean-square-error learning curves that were obtained by averaging $e^2(n)$ over 100 independent computer runs. The system to be identified has the following lattice coefficients

$$\begin{aligned} v_0=1 & \quad v_1=0 & \quad v_2=0 & \quad v_3=0 & \quad v_4=0 \\ k_1=-0.95 & \quad k_2=0.60 & \quad k_3=-0.20 & \quad k_4=0.1 \end{aligned}$$

The LAR-DH algorithm shows good convergence properties and its step size can be increased until $\mu=0.05$ without having any problem. In contrast, the K-DH algorithm has convergence problems and its μ must be reduced when the system to be identified has k coefficients close to 1 (in absolute value). In the showed results we used $\mu=0.01$. With these step sizes the convergence rate of the proposed algorithm (LAR-DH) is clearly faster than that of the (K-DH).

Figure 4 and 5 compare the coefficient tracks of the K-DH and the proposed algorithm in the same system identification case. It can be observed that the K-DH algorithm gives a track with a great oscillation when its step size is only 0.01, on the contrary, the LAR-DH algorithm results in a good convergence although its step size is 5 times greater (0.05).

Similar results have been obtained when the algorithm has been tested with other systems and the difference between both algorithms was more clear when the unknown system had the poles near of unity circle. These results are in concordance with the previously reported in [7] where the full Hessian matrix was used.

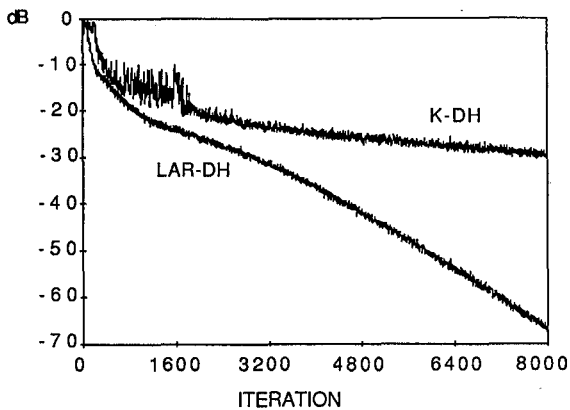
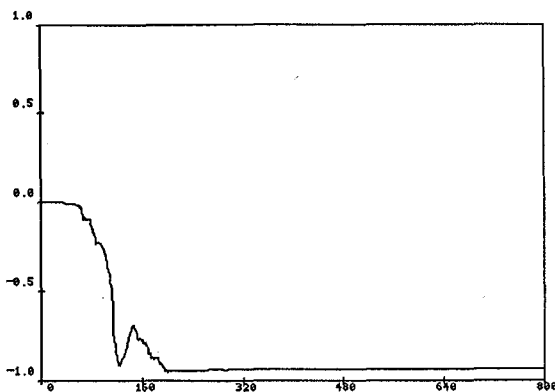
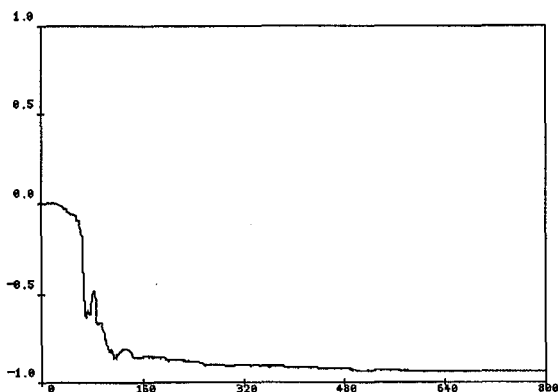

Figure 3. MSE learning curves

Figure 4. K-DH coefficient track (k_1).Figure 5. LAR-DH coefficient track (k_1).

6. CONCLUSIONS

A new algorithm for Adaptive IIR lattice filtering has been derived in which the log-area ratio parameters are updated instead of the reflection coefficients. This modification gives an error surface with no instability region and with a more uniform behavior. Effectively, the results show that the use of the log-area-ratio parameters and a simplified diagonal matrix gives an algorithm with a good convergence rate and stability.

We have derived a simplified IIR lattice gradient that makes this structure competitive in computational cost with others structures, and that allows its real time implementation using high orders.

REFERENCES

- [1] John J. Shynk. "Adaptive IIR Filtering". IEEE ASSP mag., Vol. 6, No. 2 April 1989
- [2] José A. Rodríguez - Fonollosa. "Improved Convergence of Gradient algorithms for Adaptive IIR Filters". IEEE Proc. ISCAS'89, pp 1732-1735, May 1989.
- [3] R. Viswanathan, J. Makhoul. "Quantization Properties of Transmission Parameters in Linear Predictive Systems". IEEE Trans. on ASSP, Vol 23, pp 309-321. June 1975.
- [4] John J. Shynk. "On Lattice-form Algorithms for Adaptive IIR filtering". IEEE Proc. ICASSP, pp 1554-1557. 1988.
- [5] John J. Shynk. "Performance of alternative adaptive IIR realization". Proc. 21st Asilomar Conf. Signals, Systems and Computers, Pacific Grove, CA, Nov. 1976.
- [6] I.L. Ayala, "On a new adaptive lattice algorithm for recursive filters", IEEE Trans. on ASSP, vol. 30, no.2, pp. 316-319, Apr. 1982.
- [7] J.A. Rodríguez-Fonollosa, E. Masgrau. "Spectral Sensitivity and Convergence Rate in Adaptive IIR Filtering". IEEE Proc. Int. Symp. on Circ. and Systems, May 1990.
- [8] J.A. Rodríguez-Fonollosa. "Simplified Gradient Calculation in Adaptive IIR Lattice Filters". (In preparation).