

Comparison of Environmental and Life Cycle Impact of a Switched Reluctance Motor Drive and Inverter-Fed Induction Motor Drives

P. Andrada, B. Blanqué, E. Martínez, J.I. Perat, J.A. Sánchez, M. Torrent

Grup d'Accionaments Elèctrics amb Commutació Electrònica (GAECE)
EPS d'Enginyeria de Vilanova i la Geltrú, Departament d'Enginyeria Elèctrica
Universitat Politècnica de Catalunya (UPC)
Avinguda Víctor Balaguer, s/n, 08800 Vilanova i la Geltrú, Barcelona, Spain
Tel./fax:+0034 938967732, e-mail: andrada@ee.upc.edu

Abstract. This paper compares the environmental and life cycle impact of one switched reluctance motor (SRM) drive and two inverter-fed induction motor (IM) drives. The study was carried out according to the Directive on the Ecodesign of Energy-Using Products (EuP 2005/32/EC) and following the Methodology for the Ecodesign of Energy-Using Products (MEEUP). The following base-case models were used: an IM (Eff3), an IM (Eff1) and an 8/6 SRM. All of these base-case models are rated at 1.5 kW of output power and are considered to be representative of the low-power range. The analysis shows that SRM drive has a lower environmental impact than the IM drives and offers a high savings potential, comparable to, or even greater than that of the IM (Eff1) in the use phase.

Key words

Life cycle assessment, environmental, efficiency, induction motor, switched-reluctance motors.

1. Introduction

Energy-efficient motors can save enormous quantities of energy and reduce emissions of greenhouse gases [1-2]. It is no longer enough to take into account the efficiency of an electric motor; all life cycle costs (i.e. production, use and disposal) must be considered. The Directive on the Ecodesign of Energy-Using Products (EuP 2005/32/EC) establishes requirements that certain energy-using products must fulfill in order to be placed on the market and/or put into service. The Methodology for the Ecodesign of Energy-Using Products (MEEUP) [3] was developed to determine whether, and to what extent, a product fulfills the criteria that would make it eligible under the Directive. Although energy-efficient motors are usually associated with three-phase induction motors (IMs) [4], switched-reluctance motors (SRMs) have been vying for a place in the electric motor market thanks to their simple, rugged construction, their fault-tolerance capability and their high efficiency [5]. This paper compares the environmental and life cycle impact of one SRM drive and two inverter-fed IM drives. The

study was carried out according to EuP 2005/32/EC and following the MEEUP methodology.

2. Description of the drives

Three base-case models were adopted as representative of the low-power range of variable-speed drives (VSDs): one SRM drive and two inverter-fed IM drives.

The SRM was an 8/6 SRM, 300 V, with 1.5 kW of output power and an IEC-90 frame (see Fig. 1). The SRM was designed using the FLUX 2D FEM package; Fig. 2 shows flux plots in aligned and unaligned positions. In addition, several ecodesign criteria were taken into account:

- The number of materials should be reduced.
- The number of non-recyclable parts (i.e. plastics) should be minimized.
- The motor should be easily assembled and disassembled.
- The windings should be easy to remove.

The SRM was built by the authors but has not yet been commercialized [6].



Fig. 1. Photograph of the disassembled 8/6 SRM

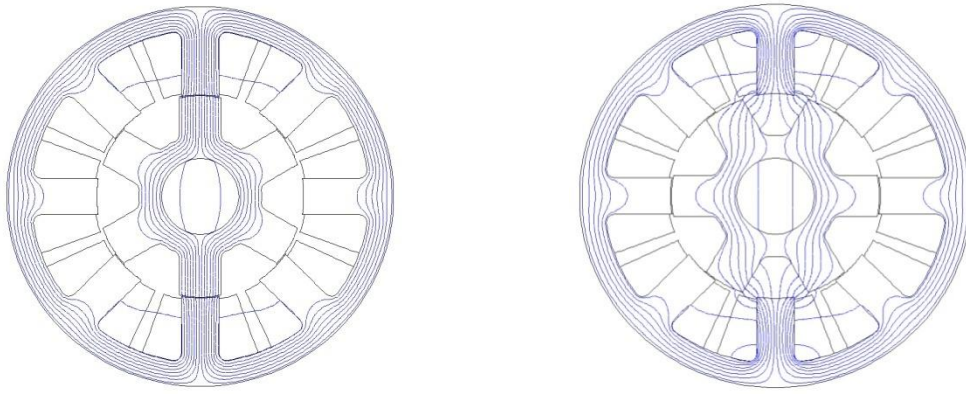

Fig. 2. Flux plots of the 8/6 SRM in aligned (left) and unaligned (right) positions obtained using the FLUX 2D FEM package

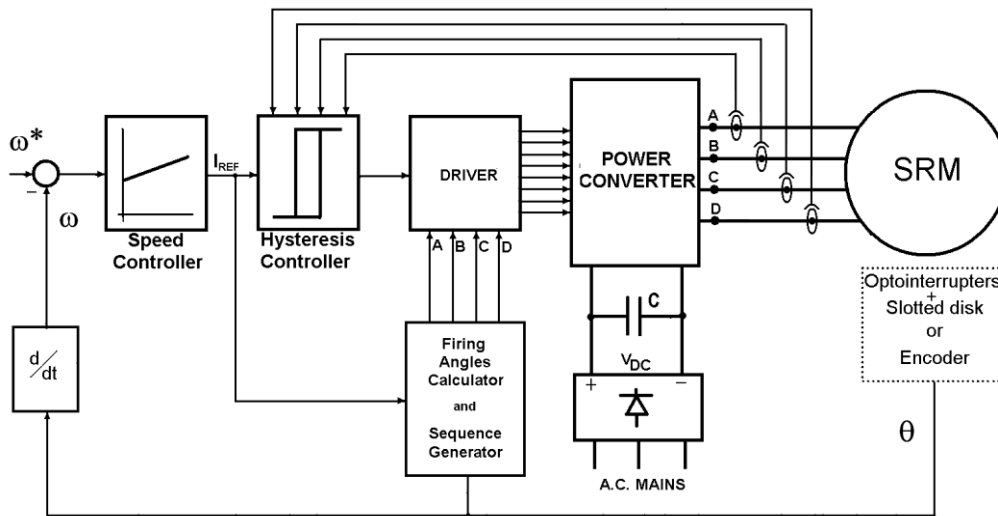

Fig. 3. Schematic diagram of the SRM drive

The SRM was controlled using the drive depicted in Fig. 3. The power converter is a four phases, half asymmetric bridge or classic converter, with two IGBTs and two fast diodes per phase. The rotor position is determined by means of an encoder or an ensemble formed by a slotted disk and three opto-interrupters placed inside the SRM. The speed controller, a proportional-integral (PI) controller, generates a current command based on the error between the reference speed and the motor speed. The current in the appropriate phase is regulated at the reference current by hysteresis control. The firing angle calculator computes the turn-on and turn-off angles at every instant, taking into account the actual speed and reference current [7].

The IMs were four poles, 230/400 V, 1.5 kW of output power and IEC-90 frame. The first was an Eff3 and the second an Eff1 (for more details, see Appendix). Both motors were driven by an inverter-fed vector control in closed loop through an incremental encoder. Both the motors and the vector-control equipment are commercially available.

A full description of the base case requires an inventory of the products used, including the packing (bill of materials). It also requires records of the energy and other resources consumed during the production phase and the use phase. Finally, it requires a scenario for recycling, re-

use and disposal. Table I, the bill of materials, shows all of the products used. Table II shows the inputs of the use phase: lifetime, global efficiency and operating hours. Global efficiency versus torque was obtained experimentally and is shown in Fig. 4 for the IM (Eff3) drive, in Fig. 5 for the IM (Eff1) drive, and in Fig. 6 for the SRM drive.

3. Environmental impact and life cycle costs

Table III shows the life cycle impact of the drives, considering a lifetime of 12 years, 4000 hours per year of operation, and an average load factor of 60%. The life cycle indicators are classified in three groups: main indicators, emissions to air, and emissions to water. It is important to point out that in this table a loss based impact analysis is presented because electric drives are considered as energy converters and not as end use devices therefore only losses are consumed inside the drives, with the remaining energy being transmitted as mechanical power. Table IV summarizes the life cycle costs (LCC). The product price list of the SRM is just an estimation. The electrical energy costs are computed considering 4000 hours of operation per year and the price of electricity in Spain. Repair and maintenance costs were considered negligible because motors smaller than 5 kW are not, normally, repaired upon failure.

TABLE I. Bill of materials

Material (kg)	IM (Eff3)	IM (Eff1)	8/6 SRM
Electrical steel	7.84	8.65	7.46
Other steel	2.18	1.73	1.50
Aluminum	5.13	5.28	4.48
Copper	1.80	2.05	2.50
Insulation material	0.07	0.07	0.01
Impregnation resin	0.44	0.44	0.20
Paint	0.15	0.15	0.06
Plastics	0.49	0.49	0.53
Electronics	0.36	0.36	0.36
Packing material	1.50	1.50	1.50

TABLE II. Use phase

Variable	IM (Eff3)	IM (Eff1)	8/6 SRM
Lifetime (years)	12	12	12
Global efficiency (%)	75.1	77.5	83.6
Operating hours	4000	4000	4000

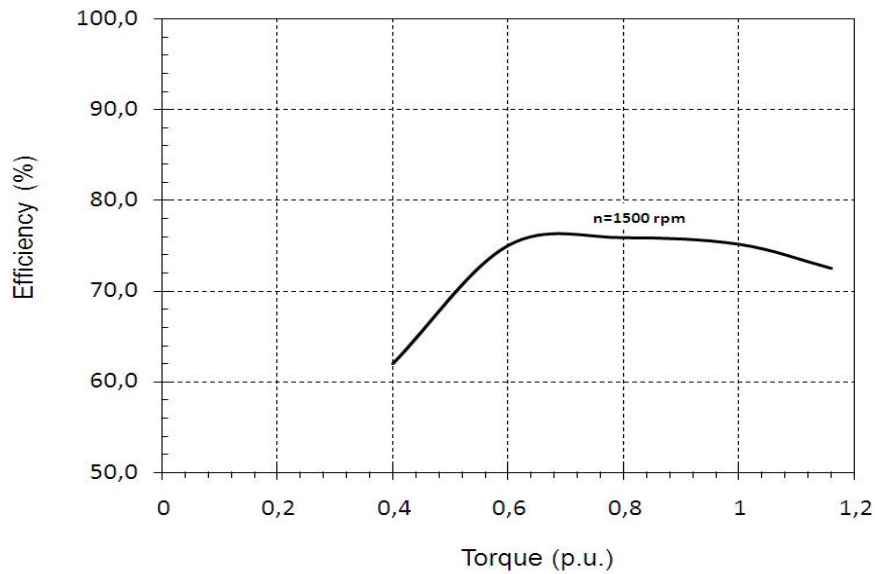

Fig. 4. Global efficiency vs. torque for the IM (Eff3) drive

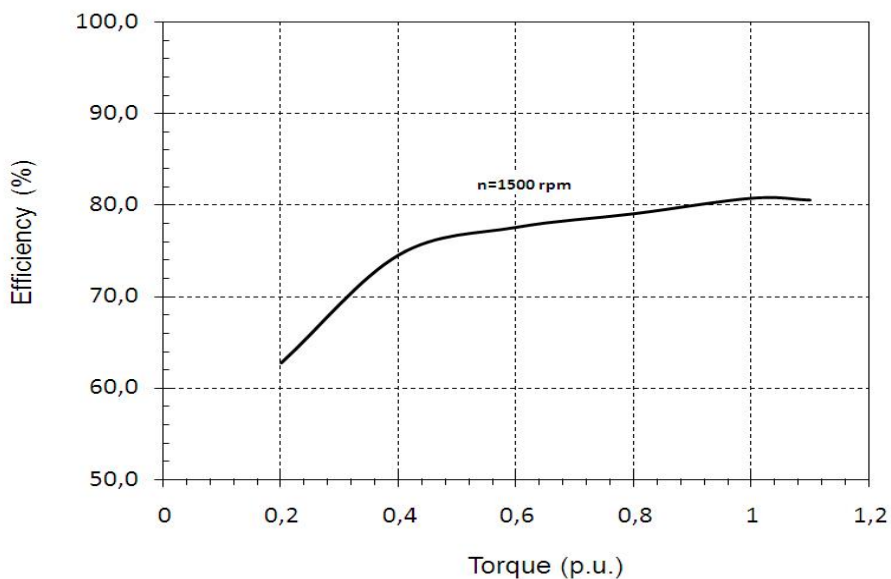

Fig. 5. Global efficiency vs. torque for the IM (Eff1) drive

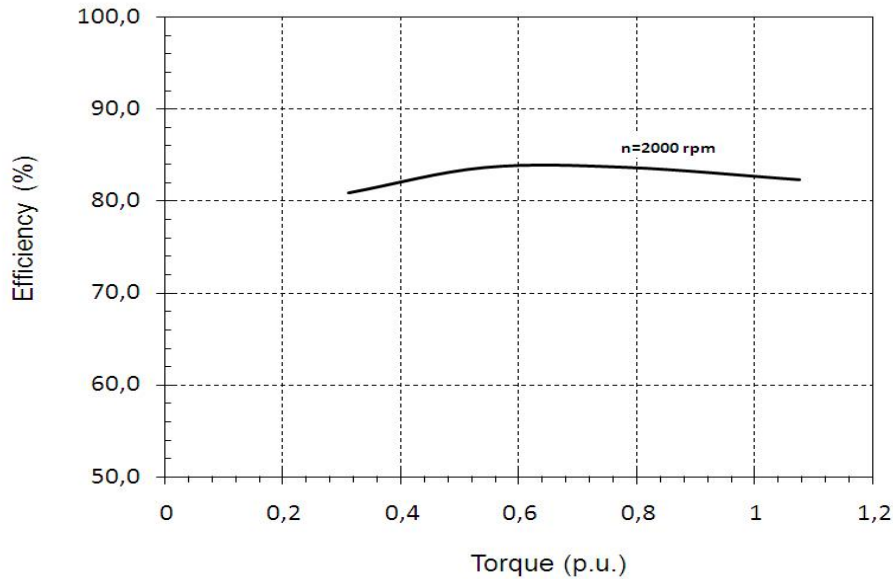

Fig. 6. Global efficiency vs. torque for the 8/6 SRM drive

TABLE III. Environmental impact for each product (drive)

Main indicators	IM (Eff3)	IM (Eff1)	8/6 SRM
Total energy GER ⁽¹⁾ (MJ)	153052	133983	91511
Of which, electricity (in primary MJ)	151022	131879	89506
Water process (l)	10205	8928	6100
Waste, non-hazardous landfill (g)	233709	217846	174648
Waste, hazardous incinerated (g)	4889	4448	3263

Emissions to air	IM (Eff3)	IM (Eff1)	8/6 SRM
Greenhouse gases in GWP100 ⁽²⁾ (kg CO ₂ eq)	6736	5905	4049
Ozone depletion emissions (mg R-11 eq)	negligible		
Acidification potential (g SO ₂ eq)	39883	35039	24226
VOC (g) ⁽³⁾	72	65	49
Heavy metals (mg Ni eq)	3013	2706	1987
Particulate matter (g)	3813	3715	3444

Emissions to water	IM Eff3	IM Eff1	SRM
Heavy metals (mg Hg/20)	1059	941	661
Eutrophication (g PO ₄)	14	14	9

- (1) Gross energy requirement
- (2) Global warming potential
- (3) Volatile organic compounds

TABLE IV. LCC for each product (drive)

Main indicators	IM (Eff3)	IM (Eff1)	8/6 SRM
Product list price (€)	123	267	384
Electrical energy (€)	1209	1055	717
Repair and maintenance costs	---	---	---

4. Conclusion

This paper has compared the environmental and life cycle impact of one 8/6 SRM drive and two IM drives that are considered to be representative of the low-power range. The analysis was carried out according to EuP

2005/32/EC and following the MEEUP methodology. The analysis showed that the SRM drive has a lower environmental impact than the IM drives in all aspects considered. In addition, the SRM drive offers a high savings potential, mainly due to its high efficiency. In the use phase, SRM motors are comparable to, or even superior to, the Eff1 three-phase IMs. Unfortunately, one

drawback of the MEEUP methodology is that it does not reflect one of the main advantages of SRM—namely, the ease with which its various parts and materials can be separated in the disposal phase.

SRM motors have not yet reached the status of standard commodity products. As a consequence, OEMs, which are mainly interested in a motor’s list price since they do not pay for operating costs, do not consider them a good choice [8]. In any event, the production phase of SRM motors must be improved in order to reduce first costs; one clear disadvantage is the large amount of magnetic steel waste generated from punching. However, this will be difficult to achieve if there are very few potential purchasers. Regulatory measures focused on minimum efficiency standards for motors would be a first step towards removing inefficient motors from the market and pushing SRMs to the frontline.

Acknowledgment

This research was supported by the Spanish Ministry of Education and Science and the European Regional Development Fund (DPI2006-09880).

References

- [1] A.T. de Almeida, F.J.T.E. Ferreira, D. Both. “Technical and Economical Considerations in the Application of Variable-Speed Drives with Electric Motor Systems,” IEEE Transactions on Industry Applications, Vol. 41, No. 1, January/February 2005, pp. 188-198.
- [2] A. Binder. “Potentials for Energy Savings with Modern Drive Technology: A Survey.” SPEDAM 2008, pp. 90-95.
- [3] http://ec.europa.eu/energy/demand/legislation/eco_design_en.htm
- [4] A.T. de Almeida, F.J.T.E. Ferreira, J. Fong, P. Fonseca. “EUP Lot 11 Motors: Final,” February 2008.
- [5] A. Binder. “Switched Reluctance Drive and Inverter-Fed Induction Machine: A Comparison of Design Parameters and Drive Performance.” Electrical Engineering 82, 2000, pp. 239-248.
- [6] FLUX User’s Manual, www.cedrat.com
- [7] E. Martínez, P. Andrada, B. Blanqué, M. Torrent, J.I. Perat, J.A. Sánchez. “Environmental and Life Cycle Cost Analysis of a Switched Reluctance Motor.” ICEM 2008, CD-ROM, 6-9 September 2008 , Vilamoura (Portugal).
- [8] A.T. de Almeida, P. Fonseca, H. Falkner, P. Bertoldi. “Market Transformation of Energy-Efficient Motor Technologies in the EU.” Energy Policy, Vol. 31, 2003, pp. 563-576.

Appendix

IM nameplate data

	IM (Eff3)	IM (Eff1)
Frame size	90L	90L
Power	1.5 kW	1.5 kW
Speed	1420 rpm	1440 rpm
Voltage	230/400V	230/400 V
Current	6.1/3.5 A	5.7/3.3 A
Power factor	0.8	0.77
IP	IP55	IP55
Insulation class	F	F