

# Protection of AC and DC distribution systems Embedding distributed energy resources: A comparative review and analysis.

Mehdi Monadi<sup>1,2,\*</sup>, M. Amin Zamani<sup>3</sup>, Jose Ignacio Candela<sup>1</sup>, Alvaro Luna<sup>1</sup>, Pedro Rodriguez<sup>1,4</sup>

<sup>1</sup> Technical University of Catalonia, Barcelona, Spain

<sup>2</sup> Shahid Chamran University of Ahvaz, Ahvaz, Iran

<sup>3</sup> Kinectrics Inc., Toronto, Canada

<sup>4</sup> Abengoa Research, Seville, Spain

**Abstract-** The integration of Distributed Generation (DG) units into distribution networks has challenged the operating principles of traditional AC distribution systems, and also motivated the development of emerging DC systems. Of particular concern is the challenges associated with the operation of conventional protection schemes and/or devices. This paper first analyses the fault current characteristics in AC and DC distribution systems; it then presents a comprehensive review of the latest protection methods proposed for distribution systems embedding DGs. In addition, the advantages and disadvantages of each method are outlined and compared. The differences between the protection algorithms employed in / proposed for AC and DC systems are also discussed. Finally, this study identifies the future trends and provides recommendation for researches in the field of protections of DC distribution networks.

**Keywords-** AC distribution systems; DC distribution systems; distributed generation; power system protection; renewable energy resources.

## 1. INTRODUCTION

The employment of Renewable Energy Systems (RESs) such as wind energy systems, Photovoltaic (PV) systems, biomass power plants, and small hydro turbines is increasing in electric networks. These resources, which constitutes one of the most relevant technologies among DGs, are typically smaller than conventional power plants and more distributed from a geographic point of view [1, 2]. Although the main part of electrical power is still generated by conventional power plants, RESs are the world's fastest growing energy market [3]. Moreover, deregulation of electric utilities based on the liberalism of power markets, increases the opportunity for further deployment of RESs and other types of DGs [4]. One of the main reasons for this worldwide attention is the environmental concerns about the effects of using conventional power plant. While conventional power plants with fossil-based fuel has a significant impact on the greenhouse emission and global warming, RESs stand out as clean resources of energy [4, 5]. On the other hand, the limitation of fossil fuels and their increasing costs, along with the limited investment on constructing new large power plants and transmission lines, are the other reasons that have contributed to the deployment of small power plants. These power plants can be connected to strategic points of distribution systems or close to load centers [2].

Despite the aforementioned incentives, the integration of renewable-energy-based DGs into power systems has dramatic effects on the energy supply and the service continuation of distribution network; it also causes fundamental changes in the topology and operation of these networks [6]. Traditionally, distribution systems are passive grids [7] which deliver the electrical power from upper voltage levels down to the loads connected to medium-/low-voltage networks without generation

---

\*Corresponding author. Tel. : +34661153290; Fax: +34 93739 8225

Email: meh\_monadi@yahoo.com

Address: Research Center on Renewable Electrical Energy Systems (SEER Center), GAIA building, 22, Rambla Sant Nebridi, 08222, Campus Terrassa, Barcelona, Spain

facilities. The topology of these systems is selected based on the required consumer reliability and economic considerations. Although loop topology has been used in distribution systems, most distribution feeders have a radial structure [8, 9]. The integration of RESs into distribution networks changes the operational philosophy of conventional power systems, especially those with the radial and passive nature [10, 11]. In other words, RESs converts the distribution system to an active network [7]. In addition, the intermittent nature of most RESs can adversely impact the operational aspects of power systems. Protection coordination, voltage control, system stability, and power quality are the major issues associated with DGs [12-14]. Particularly, protection of active distribution networks may not be adequately achieved by conventional methods, and new techniques are required [9, 15, 16].

Most RESs are interfaced with the grid through power-electronic converters [2, 17]. Therefore, using DC distribution systems can contribute to the loss/cost reduction, as some power conversion stages are eliminated [18, 19]. Moreover, compared to AC systems, DC networks can transmit higher power over longer distances. Enhancement in system safety, reduction of electromagnetic fields, and power quality improvement are other advantages of DC networks [19]. In addition to the abovementioned points, the simple integration of most modern electronic loads that are supplied by DC power has caused the concept of DC distribution systems to attract a considerable attention. It is worth mentioning that almost all voltage and current levels can be currently obtained by series or parallel combination of new power electronic devices [20, 21].

The employment of medium-voltage DC (MVDC) distribution systems has so far remained as a research topic, although they had limited application such as electrical ships [22]. However, due to their advantages, they are introduced as an alternative for AC systems in future commercial and industrial grids [23-29]. Creation of multi-microgrids [30], providing collection grids for off-shore wind farms and wide-area solar power plants [20, 31, 32], increasing the power transmission capacity of the existing AC lines [26, 33], and simple integration of industrial DC loads, [24] are some of the applications of MVDC systems. Fig. 1 shows a typical multi-terminal DC distribution system. Although MVDC systems can be considered as a future alternative for AC distribution networks, there are serious concerns about their application. Protection is one of the main key issues associated with the application of DC grids [3, 20, 34, 35]. The differences between the characteristics of AC and DC fault currents, inadequacy of conventional protection methods for fault detection, fault location, and fault interruption devices/methods are some of the protection challenges in these grids.

Aside from the type of the distribution system, it must be effectively protected against different types of faults. An effective protection scheme shall provide adequate sensitivity, redundancy, selectivity, and security [36]. Therefore, it must be designed based on the characteristics of the system as well as applicable standards/regulations. This means that the following main protection issues should be addressed in emerging AC and DC distribution systems:

- 1) The impacts of DGs on the protection schemes of existing AC distribution systems, and proposing new effective protection methods.
- 2) Identification of the protection requirements for emerging DC distribution networks.

The main objective of this paper is to provide a comprehensive and up-to-date review of the latest protection methods employed in /proposed for AC and DC distribution systems embedding DGs. The study also identifies the differences between the protection schemes in AC and DC systems. The review could be of great value for protective relay manufacturers, utility engineers as well as academicians and researchers. The rest of the paper is organized as follows: Section 2 discusses and compares the characteristics of fault currents in AC and DC systems. The protection challenges in both AC and DC systems are studied in Section 3. The proposed methods for AC and DC distribution systems are explained in Sections 4 and 5, respectively. Section 6 provides a brief comparison between the AC and DC protection schemes. Finally, the conclusions and future trends are provided in Section 7.

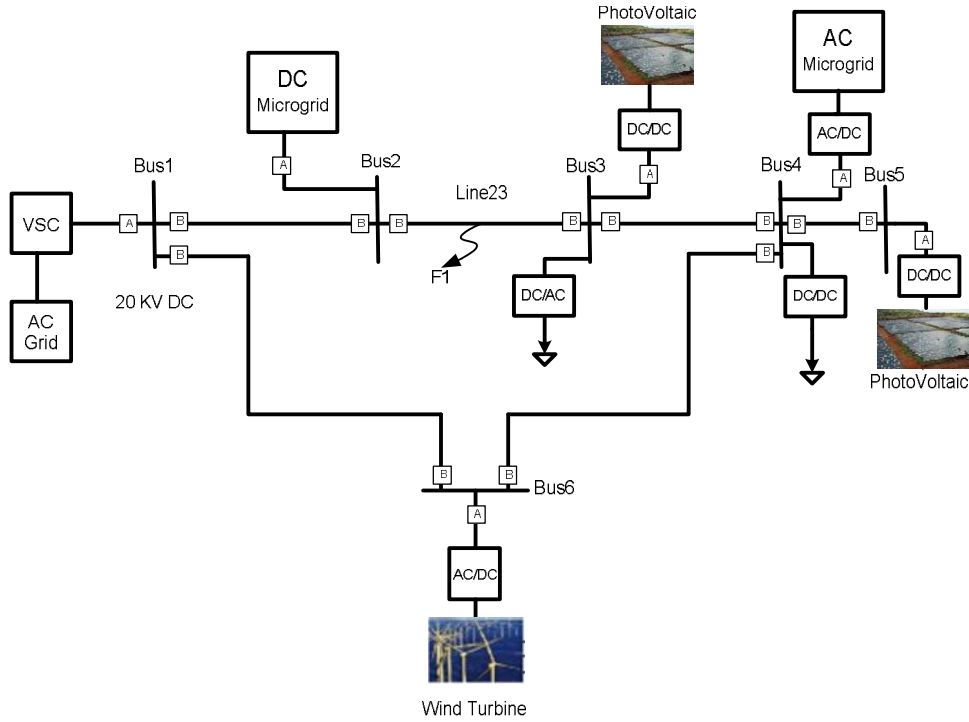

Fig 1. The structure of a prototype DC distribution system.

## 2. FAULT CHARACTERISTICS IN AC AND DC DISTRIBUTION SYSTEMS

The design of a proper fault detection method requires some knowledge of the fault current characteristics. In addition, to coordinate protective devices and to determine the type and rating of fault interrupting and/or measuring devices, the features of the fault current should be known. In this section, the main characteristics of short-circuit currents in AC and DC systems are briefly discussed while the DG impacts are ignored; the effects of DGs will be discussed in Section 3.

### 2.1. Fault Characteristics in AC Systems

Fault types vary from network to network. However, their classifications are universally accepted. They can generally be categorized to symmetrical faults, that is, three-phase faults (LLL, LLLG), and asymmetrical faults, that is, single-phase-to-ground faults (LG), phase-to-phase faults (LL), and double-phase-to-ground faults (LLG). The magnitude of the fault current depends on the type, location, and impedance of the fault. Typically, three-phase faults create maximum fault currents; Fig. 2 shows a simplified equivalent circuit of a power system when a three-phase fault impacts the network.

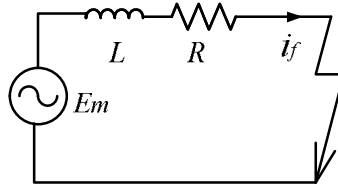

Fig 2. Equivalent circuit for LLLG fault in AC systems.

AC power systems are typically energized by three-phase synchronous generators, which can be modeled by a voltage source in series with impedance. Considering the equivalent circuit of Fig. 2, the three-phase fault current can be obtained as [36]:

$$i_f(t) = \frac{E_m}{Z} \sin(\omega t + \beta - \theta) + \left[ \frac{E_m}{Z} \sin(\theta - \beta) + i(0^+) \right] e^{-\frac{t}{\tau}} \quad (1)$$

where  $E_m$  denotes the nominal source voltage;  $Z = |Z| \angle \theta$  is the equivalent impedance, which consists of the generator impedance and the impedance from the generators terminal to the fault point, ( $Z = R + jX$ );  $\omega$  signifies the network nominal

frequency (in rad/s);  $\beta$  is the phase angle (point of wave) at which the fault is initiated;  $i(0^+)$  is the pre-fault current, and  $\tau = X/R\omega$  denotes the circuit time constant.

As Equation (1) shows, the fault current in AC networks has two components: *i*) decaying DC component and *ii*) steady-state AC component [37, 38]. Although the term steady-state is commonly used, it should be noted that the magnitude of this component is not constant during the first few cycles following the fault. Therefore, subsequent to a fault, the AC component will have different magnitudes during the three following periods [39] :

- 1) Sub-transient period, during which the magnitude of the AC component is calculated using the generator sub-transient reactance ( $x''_d$ ); this period typically lasts for less than 50ms.
- 2) Transient period, during which the generator transient reactance ( $x'_d > x''_d$ ) is used to obtain the fault current level; based on the transient reactance value, fault currents during the transient period (50ms-1s) are smaller than those experienced during the sub-transient period.
- 3) Steady-state period, during which the fault current settles at its steady-state value; the fault current at this period is calculated using the generator synchronous reactance ( $x_d > x'_d$ ) and is smaller than the sub-transient and transient fault currents.

## 2.2. Fault Characteristics in DC Systems

In bipolar DC systems, short circuit faults are divided into two main categories, namely, pole to pole faults and pole to ground faults. In pole to pole faults, the positive pole is directly connected to the negative pole (PP) or simultaneously connects to the negative pole and ground/neutral point (PPG). These faults are often of low-impedance type and, thus, endanger the system very seriously. Pole to ground (PG) faults, on the other hand, occur when either the positive or negative pole is connected to the ground or the neutral point. This type of faults, which usually occur due to the insulation degradation, are the most common types of short circuits in DC grids; however, they are not as critical as pole to pole faults [40-42].

Different types of Voltage Source Converters (VSCs) are widely employed to connect DGs to DC grids and to construct DC switchgears. For instance, a multi-level VSC is used to interface an MVDC grid with an existing AC system [43]. Connection of PV systems and/or wind farms to DC networks also requires an energy conversion mechanism, including a medium-frequency interconnection transformer [44]. The transformer is particularly necessary for the connection of low-voltage DGs. It is important to note that, in addition to the network impedance, the operational characteristics of VSCs affect the behavior of DC faults and must be considered in the design of a proper protection system. This paper mainly focuses on VSC-based DC distribution systems. The fault characteristics of PP faults are discussed in the following paragraphs.

Fig. 3 shows a simplified schematic diagram of a typical PP fault assuming that a two-level VSC is used as an interface. In this figure, R and L represent the resistance and inductance of the DC line between the main DC bus (location of DC-link capacitor) and the fault location. The analysis of the equivalent circuit of Fig. 3 indicates that the fault current is supplied by three sources, that is, *i*) DC-link capacitor, *ii*) cable inductance (discharged through freewheeling diodes), and *iii*) utility grid [45, 46]. Therefore, DC fault currents are constituted of three different components with different behavior, as follows:

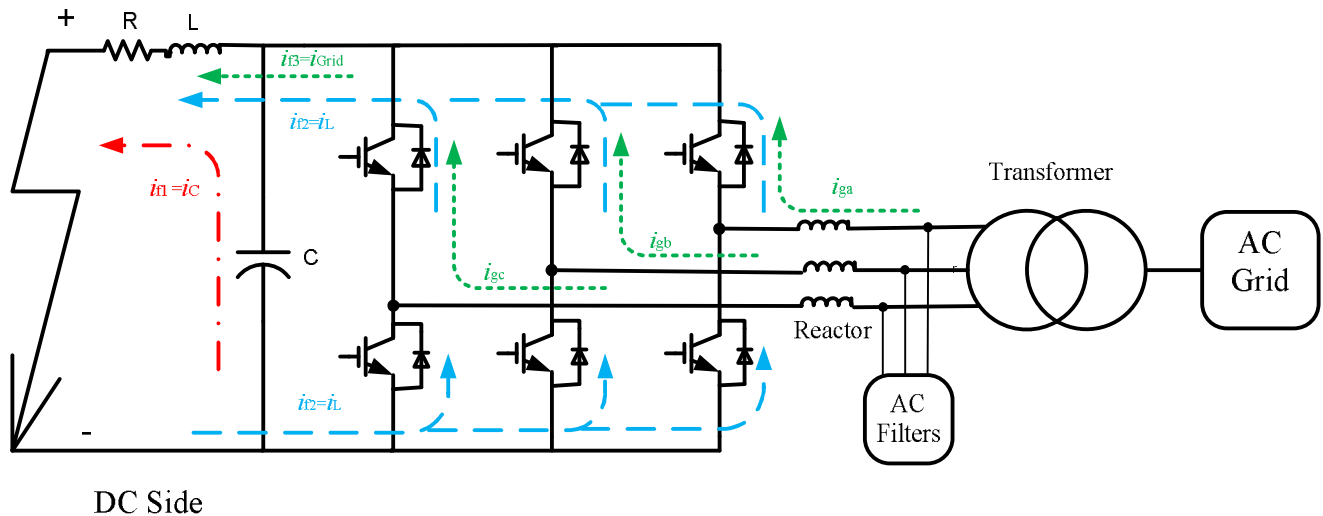

Fig 3. A simplified schematic diagram for a PP fault in a VSC-based DC grid.

### 2.2.1-DC-Link Capacitor Discharge Component

Following the occurrence of the fault in DC grids, the DC-link capacitor is discharged, mainly due to the voltage drop of the main DC bus. Using the equivalent circuit of Fig. 3 (see also Table 1), the DC-link capacitor component,  $i_c$ , can be obtained by solving the following second-order differential equation:

$$\frac{d^2 i_c}{dt^2} + \frac{R}{L} \frac{di_c}{dt} + \frac{1}{LC} i_c = 0 \quad (2)$$

where R and L denote the DC line resistance and inductance, respectively; and C represents the capacitance of the DC-link capacitor. Depending on the damping factor (i.e.,  $\xi$ ) of the RLC circuit (see Table I), three different responses can be considered for the DC-link capacitor current, namely, i) under-damped response ( $\xi < 1$ ), ii) critically damped response ( $\xi = 1$ ), and iii) Over-damped response ( $\xi > 1$ ). The damping factor, in turn, is given by:

$$\xi = \frac{R}{2} \sqrt{\frac{C}{L}} \quad (3)$$

As Equation (3) shows, the waveform of the DC-link capacitor current depends on the system impedance (R and L) as well as the DC-link capacitor (C). For example, in a short distribution feeder, if a solid fault impacts the DC line, the fault current will most likely have an under-damped form which is obtained as [45]:

$$i_c(t) = -\frac{V_0}{L\omega_d} e^{-\frac{R}{2L}t} \sin(\omega_d t) + I_0 e^{-\frac{R}{2L}t} \left[ \cos(\omega_d t) + \frac{R}{2L\omega_d} \sin(\omega_d t) \right] \quad (4)$$

where  $\omega_d = \sqrt{\frac{4L - R^2C}{4L^2C}}$ , and  $V_0$  and  $I_0$  are the initial values of the capacitor voltage and cable current.

The above discussion shows that the fault impedance can significantly affect the characteristics of the DC-link capacitor component of the fault current. In particular, the fault resistance changes both the magnitude and transient response of the fault current. It should also be pointed out that the DC-link capacitor current appears subsequent to a fault in all VSC-based DC grids, whereas the existence of the two other fault current components depends on other factors including the type and control of the VSC supplying the DC bus.

### 2.2.2-Cable-Discharge Component

Fig. 3 shows a typical VSC whose DC side is struck by a fault. Subsequent to the fault, the control scheme of the converter turns off the VSC switches (e.g., IGBTs) to protect them against the overcurrent condition. Once the switches are blocked and the DC-link capacitor is discharged ( $V_c(t) = 0$ ), the energy stored in the cable inductance will be discharged through the antiparallel freewheeling diodes. Using the equivalent circuit of this phase (see Table 1), the cable-discharge component,  $i_L$ , can be obtained by solving a first-order differential equation as follows:

$$L \frac{di_L}{dt} + i_L \cdot R = 0 \quad (5)$$

Solving (5), the cable-discharge current is calculated as:

$$i_L(t) = I_0 e^{-\frac{R}{L}t} \quad (6)$$

### 2.2.3-Grid-Side Component

Following the blocking of the main converter switches, the VSC operates as an uncontrolled full-bridge rectifier; thus, it continues to feed the fault from the AC grid through the freewheeling diode paths [47, 48]. In case of a three-phase AC-to-DC converter, this rectified current is obtained by [46]:

$$i_{Grid}(t) = i_{ga}, (> 0) + i_{gb}, (> 0) + i_{gc}, (> 0) \quad (7)$$

where  $i_{gx}$  ( $> 0$ ) denotes the positive value of phase-x current ( $i_{gx}$ ) which contribute to the fault current through freewheeling diodes. For example, the phase-a part  $i_{ga}$  ( $> 0$ ) is calculated as [46] :

$$i(t) = K_1 \sin(\omega_s t + \gamma) + K_2 e^{\frac{-R}{L_T} t} + \frac{K_3}{\omega_d} \omega_0 e^{\frac{-R}{L} t} \sin(\omega_d t + \beta) + \frac{K_4}{\omega_d} \omega_0 e^{\frac{-R}{L} t} \sin(\omega_d t) \quad (8)$$

where  $K_1 = I_g [(1 - \omega_s^2 LC)^2 + (RC\omega_s)^2]^{\frac{1}{2}}$ ;  $L_T = L_{Reactor} + L$ ;  $\gamma = \alpha - \arctan\left(\frac{RC\omega_s}{1 - \omega_s^2 LC}\right) - \arctan\left(\frac{\omega_s L_T}{R}\right)$ ;  $K_3 = -(K_1 \sin \gamma + K_2)$ ;  $K_4 = \frac{K_2 L_T}{R} - \omega_s K_1 \cos \gamma$ ;  $I_g$  is the maximum grid current amplitude; and  $\omega_s$  and  $\alpha$  are the angular frequency and phase voltage angle of phase-a of the grid voltage.

It is noted that, except the DC-link capacitor current, the other two fault current components flow through the freewheeling diodes; thus, these diodes may get damaged quickly if proper provisions are not put in place [47, 49].

### 2.3. Comparison of AC and DC Fault Current Characteristics

Based on the discussion of Sections 2.1 and 2.2, it is evident that AC and DC fault currents have different characteristics. In the view of the system protection, the main differences can be categorized as the following:

- Since the AC fault current has a sinusoidal shape, it has two zero crossing points in each period. Hence, the fault interrupting devices can break the currents during a zero crossing of the current waveform. However, DC fault currents do not cross a zero point. Consequently, AC breakers are not suitable for breaking DC fault current.
- In AC power systems, the fault impedance consists of reactance and resistance limits the fault current where the value of reactance is normally larger than its resistance. In DC networks, however, the value of reactance is quite negligible as compared to the network resistance. Consequently, not only the peak value of DC fault currents is higher than the peak value of fault currents in counterpart AC systems, but also the lower value of the fault impedance gives rise to a higher rate of change of the DC fault currents [50].
- Since DC faults cause a high-raising-rate currents, faults in VSC-based DC systems develops faster than AC systems [34, 51]. On the other hand, the withstand rating of semiconductor devices employed in VSCs is fairly lower than that in AC power generators [41]. Consequently, the protection systems in DC networks must operate relatively faster in order to prevent any damage to the converter's semiconductor (particularly, freewheeling diodes). The operating time of DC protection systems, which is in the range of several milliseconds, is typically less than the operating time of AC protection systems and is given by [46]:

$$t_1 = (\pi - \arctan((V_0 C \omega_0 \sin \frac{\beta}{V_0 C \omega_0 \cos \beta - I_0}) / \omega)) / \omega \quad (9)$$

where  $\omega_0 = \frac{1}{\sqrt{LC}}$ .

It can be concluded from Equation (9) that many of conventional protection methods for AC systems are not suitable for application in DC systems as they are not fast enough. Thus, conventional protection schemes in AC grids should be modified to fulfill the fault detection/isolation requirements in DC systems. To provide a better understanding of issues, Table 1 has summarized the main differences between the characteristics of AC (LLLG) and DC (PP) fault currents.

**Table 1.** Comparison of AC and DC fault currents characteristics.

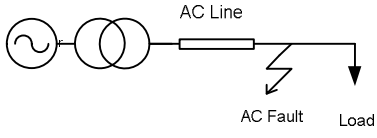
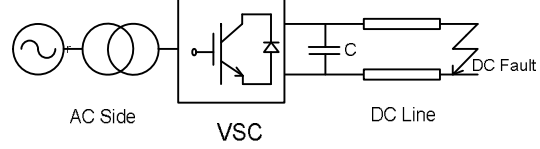
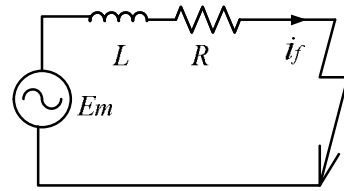
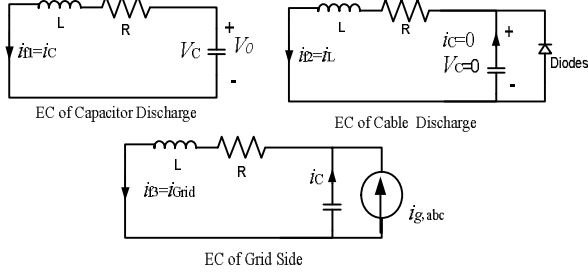
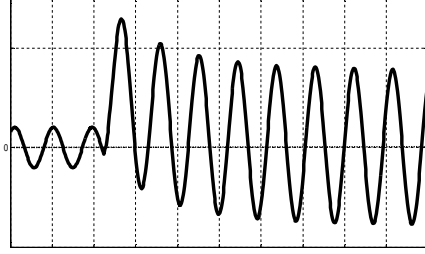
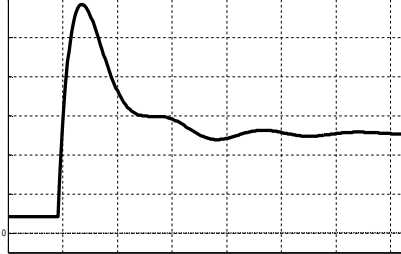
	AC Fault (LLLG)	DC Fault (PP)
Schematic of faulty feeder		
Equivalent circuit (EC) of faulty feeder		
Fault Current waveform		
First stage of fault current	Sub-transient stage: $I_f'' = \frac{V_F}{(Z_{net} + x_d')}$	Capacitor discharge current (for under-damping condition): $i_c(t) = \frac{V_0}{L\omega_d} e^{-\alpha t} \sin(\omega_d t) + I_0 e^{-\alpha t} [\cos(\omega_d t) - \frac{\alpha}{\omega_d} \sin(\omega_d t)]$
Second stage of fault current	Transient stage: $I_f' = \frac{V_F}{(Z_{net} + x_d')}$	Cable discharge current: $i_l(t) = I_0 e^{-\frac{R}{L}t}$
Final stage of fault current	Steady state current: $I_f = \frac{V_F}{(Z_{net} + x_d)}$	The rectified grid side current: $i_{grid}(t) = i_{ga}, (> 0) + i_{gb}, (> 0) + i_{gc}, (> 0)$
Zero crossing time	Based on the rated frequency.	No zero crossing point (direct current).
Maximum value of fault current	Is related to voltage and equivalent fault impedance.	Is according to the size of DC-link capacitor, DC voltage and equivalent fault impedance.
Effect of fault impedance	Change the amplitude of fault current.	Change in the fault current characteristics. (Under/over/critical damping).
Ideal fault clearing time	The first possible zero crossing point.	Before finishing the capacitor discharge stage.

### 3. PROTECTION CHALLENGES IN AC AND DC SYSTEMS

Conventional distribution systems are passive networks and are mostly arranged in radial topology [8]. These networks are normally protected by current-based devices such as O/C relays, fuses, reclosers, and sectionalizers. The O/C protective relays monitor the current flowing through a protected circuit/element and trip the CB if the current exceeds a threshold for a specific period of times. The operating time of the relay is determined by the current magnitude measured by the relay, the relay settings, and the employed time-current characteristic (definite-time or inverse-time). O/C relays provide a non-unit protection in which the physical borders of the protected zone are not specified. The main feature of the non-unit protection is that the upstream relays can provide remote backup for downstream ones. However, the coordination between the main and backup relays should be performed very accurately so that adequate selectivity and sensitivity are achieved. Conventional protection systems are designed based on the assumption of unidirectional flows of power within the network, which may be affected in the presence of DGs. With the increasing penetration of DGs, the fundamentals of distribution system protection have been challenged. In the following paragraphs, the main issues associated with the protection of AC distribution system embedding DGs as well as protection challenges of DC grids are discussed.

#### 3.1. Protection Challenges in AC Systems

As discussed in previous section, the introduction of DGs has affected several operational aspects of AC power systems including their protection philosophy [8, 52]. Although impacts of DGs on the distribution network depend on such factors as size, type, location, and interconnection interface of DGs [52-55], they can potentially change the following: *i*) fault current level of the feeder and *ii*) power flow direction on the feeder. These changes, in turn, can impact the performance of current-based protection schemes as described below.

##### 3.1.1. Change in the fault current level

DGs can change the fault current seen by a protective device depending on their size, type, location, and interconnection medium [56]. The increment in current can cause nuisance tripping if the measured current by the relay exceeds its pick-up setting. On the other hand, O/C protective devices of a distribution feeder are coordinated for a range between the minimum and maximum fault currents of that feeder. Therefore, any change in the fault current may lead to the protection mis-coordination amongst relays, fuses, and reclosers [16, 57]. Moreover, in the presence of DGs, both DG and the main grid will contribute to the fault and hence, the fault current will be shared between them. This can reduce the fault contribution of the main grid and cause a delayed operation (or non-operation) of the corresponding relays, which is known as “blinding of protection” [39]. The severity of protection blinding depends on the local short-circuit level, grid impedance, and DG capacity and location [16].

##### 3.1.2. Change in the power flow direction

Connection of a DG to a distribution feeder can also change the power flow and fault current direction in the corresponding feeder [55]. Therefore, the coordination amongst current based devices can be disrupted as most of them are non-directional units. On the other hand, when a DG is installed on a feeder, it can contribute to faults located on adjacent radial feeders. In this case, due to the change of the fault current direction (i.e., from feeder to main bus), the non-directional relays may incorrectly operate for a fault in the neighboring feeder. This issue, which is referred to as the “false tripping” in the technical literature [39], can decrease the system reliability. It should be pointed out that, with the addition of DGs to distribution networks, the demands will play a more active role in power systems. Thus, the system operational condition may regularly change. This requires the protection system adapting itself to the new operational situation in order to ensure system reliability.

#### 3.2. Protection Challenges in DC Systems

In addition to the aforementioned issues which may happen in both AC and DC systems with DGs, there are specific challenges which are related to the use of conventional protection devices in DC systems. These issues, which can exist with or without the presence of DGs, are described in the following subsections.

##### 3.2.1. Difficulties in the coordination of O/C relays

The key point in the coordination of time-inverse O/C protective devices is the discrepancy between the fault currents measured by them. Due to low value of the line reactance and the high rising rate of DC fault currents, coordination of O/C relays in DC systems is a challenging task [58, 59]. As mentioned before, the raising rate of DC fault currents is relatively higher than AC fault currents. Therefore, subsequent to the fault, all in-series O/C relays simultaneously measure a high



$I_{\text{Fault}}/I_{\text{Setting}}$  ratio. This may lead them to operate on instantaneous mode. Moreover, O/C relays must be able to effectively detect both PP and PG faults, whereas there is a significant difference between the current magnitudes of these two types of fault. If the relay settings are selected based on the PP fault currents, it may result in the delayed operation of the protection scheme for PG faults. On the other hand, selection of a low pick-up for the relay can cause protection mis-coordination for PP faults. Reference [18] has analyzed various fault scenarios for a typical DC feeder. The results of the study show that O/C relays cannot protect DC systems in a coordinated manner, leading to a decreased selectivity. Although definite-time O/C relays can be used as an option to achieve selectivity in DC systems, coordination of definite-time relays may result in a long fault clearance in large DC systems with several radial lines [60].

### 3.2.2. Inadequacy of AC circuit breakers (ACCBs)

ACCBs are conventional fault current interrupters in distribution systems; they typically have a mechanical operating mechanism which is capable of clearing the fault in several tens of milliseconds [61]. ACCBs interrupt the fault current during a zero crossing of the current waveform. DC fault currents, however, do not cross zero point. Moreover, DC systems require a relatively faster protection system capable of operating in several milliseconds to prevent any damage to the freewheeling diodes of VSCs [18, 49, 62]. Therefore, conventional ACCBs are not suitable for fault current interruption in DC systems. Different types of solid-state and hybrid DC breakers have been proposed/implemented by researchers/engineers [63, 64]. However, due to the economic and technical issues associated with these CBs, fault interrupting devices are still one of the main challenges in the development of DC systems.

Table 2 provides a summary of the main protection issues in AC distribution systems embedding DGs as well as MVDC grids.

**Table 2.** Main issues associated with the use of conventional protection schemes in AC and DC distribution systems.

Method	AC distribution systems	DC distribution systems
	Without DG: <ul style="list-style-type: none"> <li>• Coordination of protection devices.</li> <li>• Detection of High-Impedance Faults (HIF)</li> </ul>	Without DG: <ul style="list-style-type: none"> <li>• Difficult relay coordination due to the high raising rate of DC fault currents [58, 59].</li> <li>• Fault resistance changes not only the peak value of the fault current, but also changes its specifications [45].</li> </ul>
<b>O/C based fault detection</b>	With DG: <ul style="list-style-type: none"> <li>• Change in the current of the feeder which can cause nuisance tripping [54, 56].</li> <li>• Mis-coordination between current based devices due to the change in the minimum and maximum level of fault and also current direction [8, 54].</li> <li>• False tripping [39].</li> <li>• Blinding of protection [16].</li> <li>• Requirement to relays with flexible setting.</li> </ul>	With DG: <ul style="list-style-type: none"> <li>• Similar issues as AC systems.</li> <li>• Requirement for a fast action protection limits obtaining of the useful information for fault location [49].</li> </ul>
<b>AC circuit breakers</b>		<ul style="list-style-type: none"> <li>• ACCBs interrupt the fault current at zero-crossing points which do not exist in DC fault currents.</li> <li>• ACCBs are not fast enough to prevent damages on the freewheeling diodes of the VSC.</li> <li>• Major economic and technological challenges around production of solid-state or hybrid DCCBs.</li> </ul>

## 4. PROTECTION METHODS FOR AC SYSTEMS EMBEDDING DGs

As discussed above, the integration of DGs to the distribution systems results in the inefficiency of traditional O/C protection schemes. Therefore, in this section, various protection methods that have been proposed for AC distribution systems with DGs are studied.

### 4.1. Classical Alternative Methods

Due to the inadequacy of O/C relays, other traditional methods such as voltage-based methods, impedance-based methods, differential relays, and directional relays have been proposed as the first alternatives to address the protection issues associated with the DG penetration in distribution feeders. These methods are described below.

#### 4.1.1. Voltage-Based Protection

A voltage-based method has been proposed in [65] in which the RMS value of the DG terminal voltage is measured continuously. If this value is above 88% of the rated voltage, it is considered as normal condition (or an out-of-zone fault). However, when this value drops below 88% of its nominal rating, it is interpreted as a fault close to the DG; thus, the DG has to limit its output current through the intervention of the control system. The main advantage of the voltage-based methods is that their performance is independent of the value/direction of the current, which may change in the existence of DGs. However, the network voltage can be affected by various transient incidents other than faults. Therefore, this type of protection would be vulnerable to transient cases such as load switching and/or energization of dynamic loads. On the other hand, voltage-based methods cannot provide an adequate selective protection.

#### 4.1.2. Distance Protection

Distance or impedance-based protection is one of the traditional protection schemes for transmission lines. Introduction of DGs to distribution systems have made them similar to transmission networks where power can flow in both directions. Therefore, distance relays can be used for active distribution systems [66] where protection zones are defined based on the DG location. The main issue about using impedance-based relays is the effect of fault resistance on the calculated impedance. The effect is particularly important in distribution system where the lines are short and the feeders are more likely to experience high-impedance faults. In addition, the measured current by distance relay depends on the DG status which, in turn, impacts the impedance measured by the relay.

#### 4.1.3. Differential Protection

Differential relays offer a sensitive unit protection capable of detecting faults in a short period of time; moreover, the protection scheme is not affected by the DG type, location, and size. Therefore, differential relays can be used to overcome the limitation of non-unit protections in the existence of DGs [67]. As shown in Fig. 4, the relay located at one end of the line receives the current measurements from the other end via the communication link; the relay monitors the current difference between the two ends of the line and issues a trip signal if this differential current exceeds a threshold. Since unit protections cannot provide backup for other neighboring relays, differential relays should be equipped with a backup protection scheme. For example, wide area backup protection has been proposed in [68]. The implementation of this backup method in distribution feeder requires additional communication links. However, due to the requirement for the infrastructure of communication links, this method is not an economic solution for some types of small distribution system. It is noted that a synchronizing mechanism may also be needed in case the line is long [69].

#### 4.1.4. Directional O/C-Based Protection

In active distribution systems, fault current can be supplied by more than one source and fed from more than one direction. Therefore, directional overcurrent units have been used to determine the faulty feeder when each feeder embeds several DGs [15, 70].

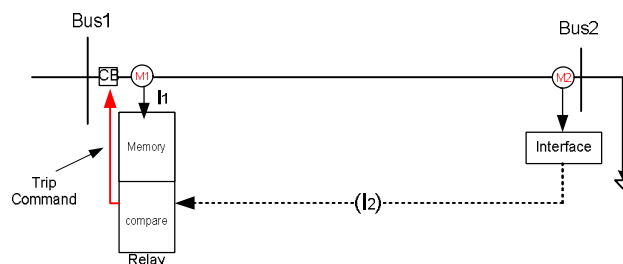

Fig 4. Differential protection scheme for distribution feeders.

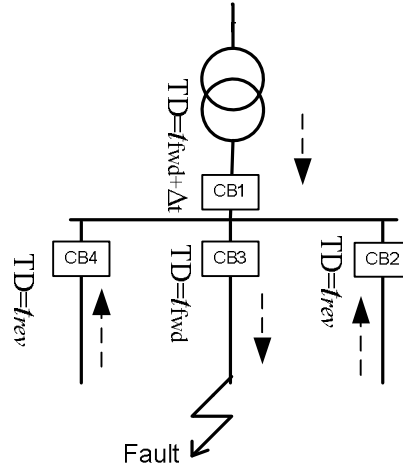

Fig 5. Directional O/C based protection [70].

Fig. 5 shows a simple three-feeder distribution system with directional O/C relays. Once a fault occurs in a feeder, it is fed by all DGs in the system as well as the main utility grid. Therefore, the O/C relays installed at the beginning of healthy feeders may measure large current in reverse direction. If non-directional relays are used, there is a possibility of protection mal-operation. Using directional units, only the protective relay of the faulty feeder operates, after  $t_{fwd}$ , and other devices work as backup for this relay. It should be noted that O/C elements are coordinated considering the presence of DGs [15]. Moreover, in addition to distribution feeders with high penetration of DGs, this method can be applied to collector grid of wind-power plants [71].

#### 4.2. Fault Current Limiting Methods

The protection issues in active distribution systems are mainly caused by the contribution of DGs to fault currents. Therefore, several methods have been proposed to decrease/eliminate the contribution of DGs to the fault without using adaptive techniques. These methods rely on either Fault Current Limiters (FCLs) or DG disconnection subsequent to the fault; they are discussed below.

##### 4.2.1. Application of Fault Current Limiters (FCLs)

FCL is a device that has no effect on the normal operation of the distribution system, but inserts a high impedance in series with the DGs (immediately after the fault inception) to limit the magnitude of the fault current [57]. These devices are used to decrease/eliminate the fault current contribution of DGs in order to prevent mis-coordination amongst O/C relays [72, 73]. Typically, FCLs have a constant impedance although the use of variable-impedance FCLs has also been proposed in the literature [57]. In these types of FCL, the impedance of the FCL is adapted according to the system operating condition. Using FCLs, the fault current level will not significantly change in different operational modes of distribution systems and, hence, protection coordination is maintained. However, the application of FCL-based methods in typical distribution systems requires more experience with these devices [74]. In addition, the performance of FCLs for transient incidents, sudden change in load current, and high-impedance faults should be thoroughly studied [75].

##### 4.2.2. Immediate Disconnection of DGs Subsequent to the Fault

In this method, all DGs connected to the faulty feeder will be disconnected from the network once a fault is detected. As such, the conventional protection will not be disrupted by DG contributions [76]. IEEE Standard 1547 recommends that, subsequent to abnormal voltages/frequencies caused by network faults, DGs must be disconnected in a pre-specified period of time [77]. Temporary/permanent disconnection of DGs in response to faults is a simple method to preserve coordination between protective devices. The main disadvantage of this method is that all DGs that experience the voltage drop will be tripped, even if they are not directly connected to the faulty feeder. Thus, the use of communication media has been proposed to prevent unnecessary tripping of DGs. For example, Reference [78], has proposed to divide the distribution system into several zones controlled by a central relay. The boundaries of zones are determined based on the location of CBs. The proposed method is able to detect the faulty zone and send the trip signals, via communication links, to corresponding CBs and DGs in order to isolate the faulty zone. Consequently, only the DGs inside the faulty zone are disconnected in response to the fault. A similar method has been proposed in [79] where Artificial Neural Network (ANN) has been used to detect the faulty zone. It should, however, be noted that recent standards make some allowance for DGs to remain connected during faults in order to mitigate voltage drops, improve system stability, and increase network reliability [80].

### 4.3. Adaptive Protection Schemes

As discussed earlier, fixed relay settings may not provide adequate protection for distribution systems with DGs. Therefore, adaptive protection schemes have been introduced such that the relay settings/characteristics are adapted based on the operational condition of the power system [81]. Most of the adaptive methods have the following common elements [56]:

- 1) A central unit for continuous monitoring of the operational parameters of the protected system such as current and voltage.
- 2) An algorithm developed in the central unit to recognize the structure of the network by analyzing vital data such as status of CBs and/or DGs.
- 3) An effective method to calculate/select new protection settings based on the system operating conditions. All required settings can be calculated off-line and stored in a look-up table or be calculated on line.
- 4) An efficient communication medium amongst protective devices and central controller.

Although the aforementioned elements are necessary for an effective adaptive scheme, they may not be sufficient. The main difference between various adaptive methods is the algorithms used to determine protection settings. Therefore, based on the complexity level of the power system, the central controller must be equipped with the proper relay coordination algorithms. The proposed methods for the calculation of relay settings in distribution systems with high penetration of DGs can broadly be divided into the following categories:

- 1) Mathematical methods: various mathematical methods such as graph analysis [82] and optimization methods [83] are used for relay coordination in loop networks. These methods can also be applied to active distribution systems; however, they are typically time consuming and must be executed after any change in the topology of the distribution system.
- 2) Intelligent methods: Genetic Algorithm (GA) [84], ANN [85-87], and fuzzy systems are some of the intelligent-based techniques that have been proposed for relay coordination in the presence of DGs.

Although adaptive methods can provide acceptable protection for active distribution systems, they are normally expensive due to the communication requirements. Moreover, after any fundamental change in the distribution system (e.g., addition of new feeder), it is necessary to update the relay coordination algorithm [88].

### 4.4. Communication-Based Methods

With the recent advances in communication technologies, it has become possible to employ accurate, secure, and safe protection methods using network-wide information. Various types of data can be transferred to different elements of protection systems through communication links. For instance, an agent-based method has been proposed in [89] to coordinate relays in the presence of DGs. In this method, to coordinate the relay settings by use of a pair-to-pair method, the adjacent relays exchange their current through communication link. A multi-agent based protection method has also been presented in [9], where the current of adjacent and remote buses are analyzed using the wavelet transform to detect the fault. Reference [78] proposed an adaptive communication-based scheme in which transfer trip signals are sent from a central relay to all CBs. In the communication-assisted method proposed in [90], the current directional information is used to detect the faulty section. Once the faulty zone is detected, a trip signal is sent out to the corresponding CB(s) to isolate the section. In [91], by use of the signs of the wavelet transform coefficients (WTC), the relay of each bus recognize that fault is inside the bus or not. If the fault is recognized to be external, each busbar relay exchange the direction of the fault current with the neighboring busbar relay(s) to determine the faulty feeder. The reliability of the communication media is the main concern associated with communication-based protection methods. In addition, it is costly to establish a high-speed communication link within the electric network.

IEC61850 is one of the standard protocols which is used in substation automation applications in order to meet the increasing demand of modern power systems [92]. It is an Ethernet-based protocol which has the capability to be translated for the future communication networks [93]. In this protocol, the data is represented in an object-oriented manner and is transmitted multiple times to ensure its receipt. Moreover, IEC61850 can be used for time-critical applications where a fast protection scheme is required [94, 95]. According to this protocol, a standard format is used for the data format which is communicated between Intelligent Electronic Devices (IEDs). Some of the advanced communication-based methods for distribution systems relay on this protocol. In [96], for example, the information of different IEDs within the network is transferred to a centralized controller using the IEC61850 protocol. The method uses multi-setting microprocessor-based relays whose settings are selected based on the network operating conditions. Reference [11] proposes a centralized protection scheme based on the standard transferred variables (data/attribute) defined by the IEC61850-7-420 protocol, that is, the recent version of IEC61850 developed for DGs. IEC 61850 has also been proposed for fault location based on the positive-sequence of voltage and current phasors of the two ends of the feeder [97].

**Table 3.** Advantages and disadvantages of protection methods in AC distribution systems embedding DGs

Protection method	Advantage	Disadvantage
Voltage based	<ul style="list-style-type: none"> <li>Stable performance against change in the value/direction of current, due to DG connection.</li> </ul>	<ul style="list-style-type: none"> <li>Operation for transient incidents and disturbances.</li> <li>Vulnerability to HIFs.</li> <li>Cannot provide adequate selectivity.</li> </ul>
Distance	<ul style="list-style-type: none"> <li>Providing backup for neighbor protection devices.</li> </ul>	<ul style="list-style-type: none"> <li>Fault impedance impacts measured impedance and cause mis-operation.</li> <li>Limited accuracy for distribution systems with short lines.</li> <li>The reach of the relay can be reduced by installed DG.</li> </ul>
Differential	<ul style="list-style-type: none"> <li>Better sensitivity</li> <li>Lower dependency to fault impedance.</li> <li>Provide selective protection.</li> <li>The current direction does not impact the fault detection methodology.</li> </ul>	<ul style="list-style-type: none"> <li>Requirement to communication link which increase the cost of the implementation.</li> <li>No backup protection is provided.</li> <li>Dependency on communication.</li> </ul>
Directional O/C	<ul style="list-style-type: none"> <li>Applicable for networks with different type of DGs</li> <li></li> </ul>	<ul style="list-style-type: none"> <li>Long delay on the operation of backup protections for large-scale power systems due to using time constant relays.</li> <li>Applicable for small scale distribution systems with radial configurations.</li> </ul>
Fault current limiting.	<ul style="list-style-type: none"> <li>No need to protection audit (DGs do not affect protection coordination).</li> </ul>	<ul style="list-style-type: none"> <li>No systematic method to find the exact values of FCL impedance.</li> <li>Requires more experience and development to provide reliable devices especially for networks with high short circuit level.</li> <li>Dependency operation time of FCL.</li> </ul>
DG disconnection	<ul style="list-style-type: none"> <li>Relays coordination is simply preserved without any external devices.</li> </ul>	<ul style="list-style-type: none"> <li>Negative network-wide impacts (e.g., on the voltage stability)</li> <li>Impacts on the sound loads and reduced selectivity/security</li> <li>Increased outage time due to the delay on returning the system to normal condition after faulty isolating.</li> </ul>
Communication based	<ul style="list-style-type: none"> <li>Can provide a fast and selective protection without any complex algorithm.</li> </ul>	<ul style="list-style-type: none"> <li>Requirement to a backup protection during the communication failures.</li> <li>Costly method due to the requirement to high speed and reliable communication.</li> </ul>
Adaptive protection	<ul style="list-style-type: none"> <li>Providing accurate setting for various operating conditions.</li> <li>Possibility of using effective algorithms for detection of such special faults as HIFs.</li> </ul>	<ul style="list-style-type: none"> <li>Communication requirements which, in turn, impact the system cost and reliability.</li> <li>Need to complex methods for relay setting calculations, especially in a high- DG penetrated environment.</li> <li>Possible requirement to revisit the protection algorithm subsequent to a change in the system.</li> </ul>

## 5. PROTECTION METHODS FOR DC SYSTEMS

Due to the specific characteristics of DC systems, they cannot be effectively protected by conventional protection methods, at least in the same manner that they are used in AC systems. Thus, modified or new fault detection/interruption methods are needed for these systems. This section describes some of the proposed methods for DC systems. It is noted that the protection methods which can be applied to both HVDC networks and MVDC distribution systems are also discussed in this section.

### 5.1. Fault Interruption Schemes

As mentioned before, one of the main protection challenges in DC distribution networks is the choice of a fast and cost-effective fault interrupting schemes [98]. This is in contrast to AC networks where the fault interrupting technology has been well developed. In the following subsections, some of the proposed methods for fault clearance in DC grids are discussed.

#### 5.1.1. Converter Blocking Schemes

All the conventional and RES-based sources are interfaced with DC grids through an energy conversion system. Therefore, the controller of converter can turn off the main converter switches subsequent to a fault occurrence to provide protection for the network. This type of protection, the “converter blocking”, causes a complete shut-down for the entire system and is normally used for HVDC lines [36, 99]. Although blocking the converter can break the fault current in line commutated converters (LCC), this method is not useful for VSC-based DC networks. Further, once the main switches of the VSC are blocked, the VSC will lose its control and the fault can be still fed through the freewheeling diodes [44]. Therefore, to provide adequate protection for VSC-based multi-terminal DC systems, revising the converter topology has been proposed [41, 62, 100]. Replacing the IGBT-Diode configuration of VSC by a structure consist of two Emitter Turn Off (ETO) has been used in [62], while [41] suggests using thyristor switches to eliminate the freewheeling effect of diodes. These methods, however, increase the initial investment on the converters. In addition, they may cause unnecessary outage of healthy load and sources, especially in multi-terminal DC systems. In addition, for a typical two-terminal DC line, it is acceptable to de-energize the line once a fault takes place within the line; however, for multi-terminal distribution systems such as the one shown in Fig. 1, this option does not provide adequate selectivity and system reliability.

#### 5.1.2. Converter Blocking with AC-Side CBs

The operation of the AC-side CBs introduced in [47] along with the converter blocking scheme can provide an economic protection method for VSC-based DC networks. In this method, after the fault occurrence and blocking the VSCs, ACCBs located on the AC-side of the VSCs operate to prevent the fault to be fed through the freewheeling diodes. Although this method can interrupt the fault current contribution from the AC side, it is not fast enough to prevent damages to the freewheeling diodes of VSCs; this is due to the fact that the operation time of medium-voltage ACCBs is in the range of several tens of milliseconds [61]. Moreover, AC-side CBs cannot break the discharge current of DC-link capacitors. Also, selectivity issues remains as the main weakness of these methods [40].

#### 5.1.3. Converter Blocking with AC-side CBS and DC Isolator Switches

To provide a selective protection, the use of fast DC isolator switches has been suggested by researchers. Although these switches cannot extinguish the fault current, they can be used to de-energize low-current and/or no-load DC feeders. Reference [101] has suggested that each DC feeder be equipped by a DC isolator switch, e.g. DC contactor, which operate in coordination with the fully controllable converters. In this method, once a fault impacts a feeder, all the converters are blocked to de-energize the DC bus. While the fault current decay to a low value, less than the nominal current of DC switch, the switch of faulty feeder operates and isolates the faulty part. Subsequently, the converter re-energizes the DC bus and sound loads. The method also proposes to equip each load with a capacitor in order to prevent any interruption of the supply during the temporary de-energizing of the DC bus. This method can provide a selective protection and prevent unnecessary outage of healthy feeders. However, the efficiency of the method for VSC-based MVDC systems is still a question under investigation; this is because the discharge current of capacitors is allowed to flow in the fault circuit, consisting of DC busbar and faulty feeder. Moreover, this method is not applicable to general structures of VSCs in which the converter is not able to interrupt the fault current.

In [102], another method has been proposed which provides selective protection for looped DC networks using DC switches. The method which has been named ‘Hand Shaking’ method is based on the coordinated operation of high-speed DC switches, converter controllers, and AC-side CBs. For a typical looped DC distribution system with DGs, as shown in Fig. 1, the switches of all converters are blocked once a fault takes place within the system. The AC-side CBs are then tripped to clear the fault. After the fault current interruption, the corresponding DC switches of the faulty feeder, labeled by B in Fig. 1, will operate to isolate the fault. Finally, the rest of the system is re-energized by closing the ACCBs and unblocking the VSCs.

These methods do not consider the requirements for proper equipment capable of breaking/reducing the capacitor discharge current; it is borne in mind that the capacitor discharge current is the most hazardous part of DC fault current and can seriously damage the system equipment. On the other hand, as mentioned in Section 5.1.2, AC-side CBs are not fast enough to prevent damages to freewheeling diodes. This is in addition to the fact that operation of AC-side CBs can impact the AC network. To that end, such methods which are based on ‘cut and try’ process can potentially threaten the system reliability [20].

#### **5.1.4. Fault Current Limiting Methods**

Limiting the fault current can protect sensitive elements employed in VSC and DC grids. For example, using a well-designed inductor at the terminal of converters has been suggested in [44]. The employment of active DC fault current limiters (FCLs) which consist of superconducting windings has been proposed in order to reduce the short-circuit level in DC systems [103]. Installation of FCLs in series with VSCs, see locations labeled by A in Fig. 1, can protect the freewheeling diodes against the fault current and mitigate the impacts of DGs on the protection coordination. On the other hand, multi-mode control schemes can also be used for special designed converters to limit the fault current in DC distribution systems; this is done by switching between different control mode as the system operating conditions changes [35, 104]. Such techniques have also been proposed for a prototype MVDC distribution network used in a shipboard [35]. In this method, the distribution system divided into various zones, and each zone is protected by Power Electronics Building Blocks (PEBB) converters. Therefore, applying this method to distribution systems requires replacing all switches (locations A and B in Figs. 1) with PEBB-based converters, resulting in a costly approach.

#### **5.1.5. Employment of DC Circuit Breakers**

DC circuit breakers (DCCBs) are designed to operate based on the specification of DC fault currents, and various applications have been proposed for them. For instance, employing a solid-state DCCB in series with the DC-link capacitor can prevent fast discharging currents from flowing [51, 62]. Although this type of CBs can interrupt the main part of the DC fault current, i.e., capacitor discharge part, they also affect the voltage of the main bus and sound feeders. Further, switching the DC-link capacitors has a destructive effect on the system power quality [45].

Reference [105] has proposed to use hybrid DCCBs at the connection point of VSCs and DC grid (locations A in Fig. 1), while fast DC isolating switches should be used in other locations within the network (locations B in Fig. 1). In this method, when a fault impacts the DC grid, all the DCCBs operate to interrupt the fault current. Then, DC switches located on both sides of the faulty part isolate the fault and, finally, the healthy parts of the network are re-energized by reclosing proper DCCBs. A similar method was also presented for DC microgrids [106], where the fault is first cleared by DCCBs as well as converter disconnection; then, re-energization of healthy parts is achieved by the operation of disconnect switches. Although these methods can provide selectivity, their operating time should be verified in accordance with power quality standards. Moreover, the application of these switching-based methods in DC systems should be investigated if industrial and sensitive loads are used in the network; this is because they may adversely impacts the reliability of DC systems [34].

Expanding upon the above discussion, it has been proposed to use independent CBs and relays for each feeder of the DC network (both locations labeled by A and B in Fig. 1) to increase the reliability of complex DC grids embedding DGs [107]. It is, however, acknowledged that economic and technical issues associated with the widespread use of DCCBs require further investigations. Table 4 summarizes the operational aspects of DC fault clearance methods in the context of the system of Fig. 1, when a fault occurs in the line between Bus2 and Bus3 (i.e., Fault F1 on LineL23).

**Table 4.** Compare the performance of fault interruption schemes for a typical VSC-based MVDC Systems, shown in Fig. 1.

<b>Fault interruption method</b>	<b>Protection system description</b>	<b>parts which loss the supply after fault at F1 (see Fig. 1)</b>	<b>Remarks</b>
Converter blocking	<ul style="list-style-type: none"> <li>Blocking the converter</li> <li>No switch in points A and B</li> </ul>	Entire DC system.	<ul style="list-style-type: none"> <li>No selective protection and reduce the reliability.</li> <li>Incapability in breaking capacitor discharge current.</li> <li>No backup protection.</li> <li>Incapability in breaking fault current feeding from AC-side (for typical VSCs).</li> </ul>
Converter blocking with AC-side CB	<ul style="list-style-type: none"> <li>Blocking the converters</li> <li>AC-side CB</li> <li>No switch in points A and B</li> </ul>	Entire DC system.	<ul style="list-style-type: none"> <li>No selective protection.</li> <li>No fast enough method to prevent damage on freewheeling diodes.</li> <li>Incapability in breaking capacitor discharge current.</li> <li>Negative impact on AC side network.</li> </ul>
Converter blocking with DC switches and AC-side CB	<ul style="list-style-type: none"> <li>Blocking the converter</li> <li>AC-side CB</li> <li>Fast isolating DC switches in points A and B</li> </ul>	Temporary overall blackout during 'cut and try' process and then Line23.	<ul style="list-style-type: none"> <li>Provide selectivity after a 'cut and try' process.</li> <li>No fast enough method to prevent damage on freewheeling diodes.</li> <li>Incapability in breaking capacitor discharge current.</li> <li>Impacts on the operation of sensitive loads.</li> <li>Negative impact on AC side network.</li> </ul>
Employment of DCCB [51, 62]	<ul style="list-style-type: none"> <li>DC CB for main capacitor</li> </ul>	Based on the existence of switches in points B.	<ul style="list-style-type: none"> <li>No backup protection.</li> <li>Destructive impacts on DC-bus voltage and power quality.</li> </ul>
Employment of DCCB [105, 106]	<ul style="list-style-type: none"> <li>DC CBs in point A</li> <li>Fast isolating DC switches in point B</li> </ul>	Temporary overall blackout during 'cut and try' process and then Line23.	<ul style="list-style-type: none"> <li>Provide selectivity after an overall blackout.</li> <li>Can impact on the operation of sensitive loads.</li> </ul>
Employment of DCCB [46, 107]	<ul style="list-style-type: none"> <li>DC CBs in both A and B Points</li> </ul>	Only the faulty line (Line23).	<ul style="list-style-type: none"> <li>Costly.</li> <li>Selective protection.</li> <li>Requirement to effective fault detection and location methods.</li> </ul>

## 5.2. Fault Detection Methods

Although different types of fault detection techniques have been proposed for AC systems, protective methods in DC systems are still in the early stage of development [58]. Moreover, the characteristics of DC systems limit the variety of the methods that can be employed to detect faults in these systems. For instance, a number of fault location methods are designed for AC systems, which work based on the phasor and harmonic analysis. However, due to the lack of frequency and phasor information, these methods are unlikely to be applied to DC systems [49]. Moreover, the lack of information in time domain limits the use of digital-signal-processing-based methods, such as DFT-based methods [58]. On the other hand, the need for a fast protection in DC networks prevents the application of those methods that extract fault data from the voltage and current waveforms [18, 49]. In the following section, the most important proposed methods for protection of active MVDC system are discussed.

### 5.2.1. Current-Based Protection

Due to the simplicity of O/C protection, they are always the first choice for the protection of AC distribution systems. However, as explained in Section 3.2., this type of protection does not provide adequate selectivity for multi-terminal DC systems. Nonetheless, these relays can be used along with other types of protective functions to protect small DC grids. For instance, Reference [25] has proposed to analyze the magnitude of DC-link voltage along with the fault current in order to locate the fault in low-voltage DC microgrids. In Reference [62], a hybrid relay has been devised which is based on overcurrent and under-voltage elements; once both the overcurrent and under-voltage element pick up, the relay confirms the occurrence of the fault. The methodology proposed in [108] and the O/C-based relay suggested in [109] have been designed



based on the slope of the current in DC networks. However, as discussed in Section 3.1., the O/C-based methods can potentially fail when DGs are integrated into the network.

Establishing communications between O/C relays has been proposed to improve the protection selectivity. For instance, References [110] suggests using the current magnitude, current direction, and voltage of the DC bus to provide a fast and reliable protection for low-voltage DC networks. In this method, faults are detected by monitoring the DC current of the individual feeders and the voltage of the DC bus. Then, the faulty feeder is determined based on the direction of the DC fault currents. It is noted that the feeder relays exchange the information of fault current directions via a suitable communication link. If a relay detects the fault with a forward current direction, its corresponding feeder is recognized as the faulty feeder and is disconnected from the DC bus.

### 5.2.2. Distance Protection

In [46], a distance protection scheme has been proposed for MVDC networks. The salient difference between the proposed method and the conventional distance protection in AC system is on the calculation of the fault location. As compared to AC systems, the method of Reference [46] employs a simpler formulation to achieve a fast fault detection. According to the proposed methodology, the fault distance is estimated using two DC measuring elements installed on the protected line, and is given by:

$$x = \frac{v(n)}{v(n) - v(r)} d \quad (10)$$

where  $v(n)$  and  $v(r)$  are the measured voltages by the two DC measuring elements, and  $d$  denotes the distance between these two measuring devices. This method has a favorable fast detecting time and also is applicable in DC systems with DGs. Active impedance estimation (AIE) has also been suggested in [111], where a current with a wide-range frequency is injected to the DC feeder while the resultant voltage is recorded. Then, using the measured voltage and current, the equivalent system impedance is estimated. The main challenge associated with the distance protection is that it is vulnerable to the fault impedance. Also, the choice of a proper frequency range for injected current is an important shortcoming of the AIE method.

### 5.2.3. Differential Protection

As discussed in Section 4.1.3, differential protection has an accurately defined protection zone. The fault current level, the rate-of-change-of the current, existence of DGs, and fault resistance have relatively low impact on the performance of differential protection, making differential protection one of the best options for the protection of DC systems [18]. Reference [40] has proposed a protection methods for DC systems in which each section of the system is protected by a master controller; the controller, in turn, operates based on the difference between the measured currents at two ends of the protected section. If the current difference is more than a threshold, it is interpreted as a fault and trip commands are sent to the solid-state switches located at both ends of the faulty section. References [112, 113] suggested that a telecommunication link should be used between the protective devices in the both sides of each DC feeder. Then, each differential relay, which is installed on one side of the line, will only send the trip command to its corresponding CB. It is remembered that the protection system must be very fast for DC systems and, thus, differential protection is a proper choice. The results of Reference [114] show that differential-based protection methods can detect DC faults in less than 40 $\mu$ s while the operating time of differential protection in AC networks is more than 20ms; these times are without considering the communication delay. It is worth noting that most of differential relays in Ac systems have to compare both the magnitude and the phase-angle of 3phase currents, whereas only the current magnitude are compared in DC systems; therefore, it can operate faster. It should be pointed out that communication delay and/or failure must also be taken into consideration when differential protection systems are designed, especially in case of MVDC feeders. For example, Reference [107] has employed O/C relays to provide backup protection if the communication network fails. Nonetheless, providing remote backup for adjacent protections, dependency on the communication network, and potential need for synchronized measurements in large systems are some of the challenges associated with differential protection in DC systems.

### 5.2.4. Signal-Processing Based Methods

To overcome the challenges about the fault location in DC grids and provide a selective protection for these systems, wavelet-transform-based methods have been suggested in [34, 115, 116]. In these methods, the criteria of fault location are defined based on the analysis of DC voltage and currents through wavelet transform (WT). For instance, a fault detection/location technique has been proposed in [34], which is based on the wavelet-transform coefficients of voltage and current as well as magnitude and derivative of the voltage. On the other hand, References [116] has used complex-wavelet coefficients of transient currents to detect DC faults. The use of a feature vector containing the energy of wavelet coefficients has been suggested in [115]; the proposed vector is generated based on the multi-resolution analysis (MRA) and compared with a

predefined threshold to detect the fault. The method proposed in [115] has also shown satisfactory results for the DC systems in the presence of DGs. However, since the fault location criteria and settings vary from network to network, the application of feature network may not provide a generic method for DC systems.

Artificial Neural Networks (ANNs) have widely been used in AC power system. In most cases, the input data to ANN is obtained from the analysis of post-fault waveforms. For instance, Fourier transform has been used in [117] to extract the harmonic contents of voltages/currents in order to feed an ANN. However, as mentioned before, FFT cannot be easily used in DC systems due to the lack of time-domain information as well as required time for the process. Therefore, it has been suggested in [118] that the sampled value of DC current and voltage be fed to ANN directly. The main concerns about the direct use of voltage and current samples include noise and incorrect sampling [34]. Therefore, the use of wavelet transform and multi-resolution analysis (MRA) has respectively been suggested in [58, 119] in order to extract the feature vector of faults and feed them to an ANN. It is worth mentioning that the ANN-based protection schemes have the capability of both detection and classification of DC faults.

The travelling-waves-based protection methods are also proposed for DC systems [120-122]. Following the fault occurrence in a line, the travelling waves are propagated from the fault point to the both sides of the line. By using the synchronized measurements, the accurate difference in arrival times of the travelling waves to each end of the line is determined. This means if the velocity of travelling waves is known, the fault location can be calculated. Reference [120] has used a travelling-wave-based method to protect multi-terminal DC systems with DGs. However, due to the small length of distribution feeders, it is very difficult to obtain the exact time difference and locate the faulty feeder. Moreover, since the travelling waves propagate along the lines of a multi-terminal system, most of the measurement devices installed within the DC network may receive these waves. As such, the travelling wave boundary method of Reference [122] may not find the exact location of the fault [116]. The abovementioned issues should be added to the concerns associated with the use of some sort of synchronizing mechanism for travelling waves in long lines

## **6. COMPARISON OF PROTECTION METHODS IN AC AND DC NETWORKS**

Different protection methods for AC and DC distribution networks were explained in Section 4 and 5, respectively. The main features of these methods are summarized and compared in Table 5.

**Table 5.** A summary of protection methods in AC and DC networks.

Fault detection method	AC distribution systems	DC distribution systems
Over current	<ul style="list-style-type: none"> <li>Simple algorithm.</li> <li>Inefficient in the presence of DGs.</li> </ul>	<ul style="list-style-type: none"> <li>Fast method.</li> <li>Should be used with other methods or equipped with communication links to provide selectivity.</li> <li>Applicable in fault interrupt methods based on blocking the converters when selectivity is not desired.</li> </ul>
Differential	<ul style="list-style-type: none"> <li>Mostly, phase and Magnitude of three-phase currents are compared.</li> <li>Detects faults in 20-50ms.</li> </ul>	<ul style="list-style-type: none"> <li>Only the magnitudes of DC currents are compared.</li> <li>Faster than AC differential relays.</li> <li>Insensitive to high raising rate of DC currents and fault resistance.</li> </ul>
Distance	<ul style="list-style-type: none"> <li>The measured current and voltage are used for distance estimation.</li> <li>Use of symmetrical components analysis to avoid the impact of fault resistance.</li> </ul>	<ul style="list-style-type: none"> <li>Simple algorithm (use simpler fault location estimator).</li> <li>Faster than AC relays.</li> <li>More sensitivity to fault resistance (as compared to AC systems).</li> </ul>
Fault current limiting	<ul style="list-style-type: none"> <li>Typically consists of constant or variable inductors.</li> </ul>	<ul style="list-style-type: none"> <li>Can be done by external inductors, or the current limiting modes of especial converter.</li> <li>Requires high-speed semiconductor switches.</li> <li>Requires devices with higher withstand rating DC current with high raising rate.</li> </ul>
Intelligent methods such as ANN, Fuzzy	<ul style="list-style-type: none"> <li>Fast methods for fault detection, classification, and location without requirement to complex mathematical equations.</li> <li>Requirements for analysis of the post-fault waveforms to input proper data to the ANN.</li> </ul>	<ul style="list-style-type: none"> <li>Frequency based transformations are not applicable for obtaining the input data.</li> <li>Direct use of sampled data to the ANN increases the complexity of its structure and its training time.</li> <li>Direct use of measured data increases the impact of noises and reduces the accuracy.</li> </ul>
Wavelet transform	<ul style="list-style-type: none"> <li>Effective for fault detection and location with or without other methods, e.g. wavelet-ANN, wavelet-Fuzzy, etc.</li> </ul>	<ul style="list-style-type: none"> <li>Applicable for the analysis post-fault waveforms.</li> <li>Can be used with intelligent methods for the protection of DC systems with DGs.</li> </ul>
Communication Based	<ul style="list-style-type: none"> <li>Is increasing in distribution systems and smart grids due to the providing a fast, accurate and selective protection.</li> </ul>	<ul style="list-style-type: none"> <li>Can be applicable for coordination of O/C relays instead of using time grading methods.</li> <li>Delay on the communication link can be a major concern.</li> <li>Lack of the standard protocols for DC systems.</li> </ul>
Directional O/C	<ul style="list-style-type: none"> <li>Detects the fault current direction according to the relative phases of the voltage and current.</li> </ul>	<ul style="list-style-type: none"> <li>Requirement to accurate and fast methods for detecting the current direction.</li> </ul>

## 7. CONCLUSIONS AND FUTURE TRENDS

This paper analyzed the fault current characteristics in AC and DC distribution systems. The issues associated with the protection of these systems in the presence of DGs were also explained in the paper. Moreover, the methods proposed for the protection of both AC and DC distribution systems embedding DGs have been compared. The analyses reviewed in this study show that the conventional protection schemes must be modified to provide adequate protection for distribution systems with DGs. In particular, the realization of future DC systems requires further investigation about protection issues/solution, especially in multi-terminal DC systems with DGs. The outcomes of this study are of great interest for protective relay manufacturers, utility engineers as well as academicians and researchers. The following are specific conclusions and/or recommendations of this study for future works:

- Fault detection/location methods in AC systems heavily rely on the processing of local values (current, voltage, harmonic contents, etc.) that are not effective for DC systems. Moreover, conventional protection methods, such as directional O/C relays and distance protection, must be modified based on the characteristics of DC networks during

faults and transient incidents. Therefore, worldwide application of DC distribution systems requires a fresh look into the traditional protection schemes.

- The effect of fault resistance on AC and DC systems are not exactly the same. Therefore, the proposed methods for high-impedance fault detection in AC systems are not necessarily applicable to DC systems. However, to the best of authors' knowledge, no independent study has been conducted on the detection and location of high-impedance faults in DC distribution systems.
- Due to the characteristics of DC fault currents, ACCBs are not suitable for fault current interruption in DC systems. On the other hand, economical concerns and technical challenges preclude the widespread use of DCCBs. Therefore, further studies are required to address the issues associated with fault breaking devices in DC distribution systems; the problem particularly manifests itself in medium-voltage level and above.
- The high rising rate of DC fault currents makes it difficult to coordinate current-based protective devices in these systems. Although the use of communication technologies may enhance the performance of DC protection systems and improve the selectivity, there are other issues such as communication delays and the speed of fault detection methodology which should be taken into consideration.
- The grounding method has a significant impact on the fault behavior and, hence, protection performance in DC systems. However, this factor has not been fully investigated in the existing technical literature. It is an important subject that should be addressed in the future studies.

## Acknowledgements

This work was supported in part by the Spanish Ministry of Economy and Competitiveness under Project ENE2013-48428-C2- 2-R. The work of M.Monadi was supported by the Ministry of Science, Research, and Technology, Iran. Any opinions, findings, and conclusions or recommendations expressed in this material are those of the authors and do not necessarily reflect those of the host institutions or founders.

## 8. REFERENCES

- [1] [1] Borges CLT. An overview of reliability models and methods for distribution systems with renewable energy distributed generation. *Renewable and Sustainable Energy Reviews*. 2012;16:4008-15.
- [2] Justo JJ, Mwasilu F, Lee J, Jung J-W. AC-microgrids versus DC-microgrids with distributed energy resources: A review. *Renewable and Sustainable Energy Reviews*. 2013;24:387-405.
- [3] Karabiber A, Keles C, Kaygusuz A, Alagoz BB. An approach for the integration of renewable distributed generation in hybrid DC/AC microgrids. *Renewable Energy*. 2013;52:251-9.
- [4] Tan W-S, Hassan MY, Majid MS, Abdul Rahman H. Optimal distributed renewable generation planning: A review of different approaches. *Renewable and Sustainable Energy Reviews*. 2013;18:626-45.
- [5] Joselin Herbert GM, Iniyana S, Amutha D. A review of technical issues on the development of wind farms. *Renewable and Sustainable Energy Reviews*. 2014;32:619-41.
- [6] Abdullah M, Agalgaonkar A, Muttaqi K. Assessment of energy supply and continuity of service in distribution network with renewable distributed generation. *Applied Energy*. 2014;113:1015-26.
- [7] Marvasti AK, Yong F, DorMohammadi S, Rais-Rohani M. Optimal Operation of Active Distribution Grids: A System of Systems Framework. *Smart Grid, IEEE Transactions on*. 2014;5:1228-37.
- [8] Conti S. Analysis of distribution network protection issues in presence of dispersed generation. *Electric Power Systems Research*. 2009;79:49-56.
- [9] El-Zonkoly AM. Fault diagnosis in distribution networks with distributed generation. *Electric Power Systems Research*. 2011;81:1482-90.
- [10] Pandi VR, Zeineldin H, Xiao W. Determining optimal location and size of distributed generation resources considering harmonic and protection coordination limits. *Power Systems, IEEE Transactions on*. 2013;28:1245-54.
- [11] Ustun TS, Ozansoy C, Zayegh A. Modeling of a centralized microgrid protection system and distributed energy resources according to IEC 61850-7-420. *Power Systems, IEEE Transactions on*. 2012;27:1560-7.
- [12] Coster EJ, Myrzik JM, Kruimer B, Kling WL. Integration issues of distributed generation in distribution grids. *Proceedings of the IEEE*. 2011;99:28-39.
- [13] Basak P, Chowdhury S, Halder nee Dey S, Chowdhury S. A literature review on integration of distributed energy resources in the perspective of control, protection and stability of microgrid. *Renewable and Sustainable Energy Reviews*. 2012;16:5545-56.
- [14] Ruiz-Romero S, Colmenar-Santos A, Mur-Pérez F, López-Rey Á. Integration of distributed generation in the power distribution network: The need for smart grid control systems, communication and equipment for a smart city — Use cases. *Renewable and Sustainable Energy Reviews*. 2014;38:223-34.

- [15] Zamani MA, Sidhu TS, Yazdani A. A Protection Strategy and Microprocessor-Based Relay for Low-Voltage Microgrids. *Power Delivery, IEEE Transactions on*. 2011;26:1873-83.
- [16] Firouz Y, Lobry J, Vallée F, Durieux O. Numerical Comparison of the Effects of Different Types of Distributed Generation Units on Overcurrent Protection Systems in MV Distribution Grids. *Renewable Energy: An International Journal*. 2014.
- [17] Noroozian R, Abedi M, Gharehpetian G, Hosseini S. Distributed resources and DC distribution system combination for high power quality. *International Journal of Electrical Power & Energy Systems*. 2010;32:769-81.
- [18] Fletcher SDA, Norman PJ, Galloway SJ, Crolla P, Burt GM. Optimizing the Roles of Unit and Non-unit Protection Methods Within DC Microgrids. *Ieee T Smart Grid*. 2012;3:2079-87.
- [19] Elsayed AT, Mohamed AA, Mohammed OA. DC microgrids and distribution systems: An overview. *Electric Power Systems Research*. 2015;119:407-17.
- [20] Yang J, Fletcher JE, O'Reilly J. Multiterminal DC wind farm collection grid internal fault analysis and protection design. *Power Delivery, IEEE Transactions on*. 2010;25:2308-18.
- [21] Dastgeer F. Direct current distribution systems for residential areas powered by distributed generation: Victoria University; 2011.
- [22] Arcidiacono V, Monti A, Sulligoi G. Generation control system for improving design and stability of medium-voltage DC power systems on ships. *IET Electrical Systems in Transportation*. 2012;2:158.
- [23] Nilsson D, Sannino A. Efficiency analysis of low-and medium-voltage dc distribution systems. *Power Engineering Society General Meeting, 2004 IEEE: IEEE; 2004*. p. 2315-21.
- [24] Baran ME, Mahajan NR. DC distribution for industrial systems: opportunities and challenges. *Industry Applications, IEEE Transactions on*. 2003;39:1596-601.
- [25] Salomonsson D, Soder L, Sannino A. Protection of low-voltage DC microgrids. *Power Delivery, IEEE Transactions on*. 2009;24:1045-53.
- [26] Larruskain DM, Zamora I, Abarrategui O, Iturregi A. VSC-HVDC configurations for converting AC distribution lines into DC lines. *International Journal of Electrical Power & Energy Systems*. 2014;54:589-97.
- [27] De Doncker RW, Meyer C, Lenke RU, Mura F. Power electronics for future utility applications. *Power Electronics and Drive Systems, 7th International Conference on: IEEE; 2007*. p. K-1-K-8.
- [28] Mura F, De Doncker RW. Design aspects of a medium-voltage direct current (MVDC) grid for a university campus. *Power Electronics and ECCE Asia (ICPE & ECCE), 2011 IEEE 8th International Conference on: IEEE; 2011*. p. 2359-66.
- [29] Planas E, Andreu J, Gárate JI, de Alegría IM, Ibarra E. AC and DC technology in microgrids: A review. *Renewable and Sustainable Energy Reviews*. 2015;43:726-49.
- [30] Majumder R. Aggregation of microgrids with DC system. *Electric Power Systems Research*. 2014;108:134-43.
- [31] Rufer A, Kenzelmann S. Modular DC/DC Converter for DC Distribution and Collection Networks [PhD]: ÉCOLE POLYTECHNIQUE FÉDÉRALE DE LAUSANNE; 2012.
- [32] Chen W, Huang AQ, Li C, Wang G, Gu W. Analysis and comparison of medium voltage high power DC/DC converters for offshore wind energy systems. *Power Electronics, IEEE Transactions on*. 2013;28:2014-23.
- [33] Larruskain DM, Zamora I, Abarrategui O, Aginako Z. Conversion of AC distribution lines into DC lines to upgrade transmission capacity. *Electric Power Systems Research*. 2011;81:1341-8.
- [34] De Kerf K, Srivastava K, Reza M, Bekaert D, Cole S, Van Hertem D, et al. Wavelet-based protection strategy for DC faults in multi-terminal VSC HVDC systems. *Generation, Transmission & Distribution, IET*. 2011;5:496-503.
- [35] Li H, Li W, Luo M, Monti A, Ponci F. Design of smart MVDC power grid protection. *Instrumentation and Measurement, IEEE Transactions on*. 2011;60:3035-46.
- [36] Anderson PM. *Power system protection*: McGraw-Hill New York; 1999.
- [37] Grainger JJ, Stevenson WD. *Power system analysis*: McGraw-Hill New York; 1994.
- [38] Kundur P, Balu NJ, Lauby MG. *Power system stability and control*: McGraw-hill New York; 1994.
- [39] Darwish A, Abdel-Khalik A, Elserougi A, Ahmed S, Massoud A. Fault current contribution scenarios for grid-connected voltage source inverter-based distributed generation with an LCL filter. *Electric Power Systems Research*. 2013;104:93-103.
- [40] Park J-D, Candelaria J. Fault Detection and Isolation in Low-Voltage DC-Bus Microgrid System. *IEEE Transactions on Power Delivery*. 2013;28:779-87.
- [41] Li X, Song Q, Liu W, Rao H, Xu S, Li L. Protection of nonpermanent faults on DC overhead lines in MMC-based HVDC systems. *Power Delivery, IEEE Transactions on*. 2013;28:483-90.
- [42] Jimmy Ehnberg TN. Protection system design for MVDC collection grids for off-shore wind farms. *Elforsk rapport 12:02*. [elforsk.se/Rapporter/?download=report&rid=12\\_02\\_2011](http://elforsk.se/Rapporter/?download=report&rid=12_02_2011).
- [43] Falcones S, Mao X, Ayyanar R. Topology comparison for solid state transformer implementation. *Power and Energy Society General Meeting, 2010 IEEE: IEEE; 2010*. p. 1-8.
- [44] Deng F, Chen Z. Design of protective inductors for HVDC transmission line within DC grid offshore wind farms. *Power Delivery, IEEE Transactions on*. 2013;28:75-83.
- [45] Fletcher S, Norman P, Galloway S, Burt G. Determination of protection system requirements for DC unmanned aerial vehicle electrical power networks for enhanced capability and survivability. *IET Electrical Systems in Transportation*. 2011;1:137-47.
- [46] Yang J, Fletcher JE, O'Reilly J. Short-circuit and ground fault analyses and location in VSC-based DC network cables. *Industrial Electronics, IEEE Transactions on*. 2012;59:3827-37.
- [47] Candelaria J, Park J-D. VSC-HVDC system protection: A review of current methods. *Power Systems Conference and Exposition (PSCE), 2011 IEEE/PES: IEEE; 2011*. p. 1-7.
- [48] Tang L, Ooi B-T. Protection of VSC-multi-terminal HVDC against DC faults. *Power Electronics Specialists Conference, 2002 pesc 02 2002 IEEE 33rd Annual: IEEE; 2002*. p. 719-24.

- [49] Park JD, Candelaria J, Ma LY, Dunn K. DC Ring-Bus Microgrid Fault Protection and Identification of Fault Location. *IEEE Transactions on Power Delivery*. 2013;28:2574-84.
- [50] Jin C, Dougal RA, Liu S. Solid-state Over-current Protection for Industrial DC Distribution Systems. 4th International Energy Conversion Engineering Conference and Exhibit (IECEC). 2006:26-9.
- [51] Peng C, Huang AQ. A protection scheme against DC faults VSC based DC systems with bus capacitors. *Applied Power Electronics Conference and Exposition (APEC), 2014 Twenty-Ninth Annual IEEE: IEEE; 2014*. p. 3423-8.
- [52] Ai Q, Wang X, He X. The impact of large-scale distributed generation on power grid and microgrids. *Renewable Energy*. 2014;62:417-23.
- [53] Kamel RM. Effect of wind generation system types on Micro-Grid (MG) fault performance during both standalone and grid connected modes. *Energy Conversion and Management*. 2014;79:232-45.
- [54] Javadian SAM, Haghifam MR, Fotuhi Firoozabad M, Bathaee SMT. Analysis of protection system's risk in distribution networks with DG. *International Journal of Electrical Power & Energy Systems*. 2013;44:688-95.
- [55] Girgis A, Brahma S. Effect of distributed generation on protective device coordination in distribution system. *Power Engineering, 2001 LESCOPE'01 2001 Large Engineering Systems Conference on: IEEE; 2001*. p. 115-9.
- [56] Geidl M. Protection of power systems with distributed generation: state of the art: ETH, Eidgenössische Technische Hochschule Zürich, EEH Power Systems Laboratory; 2005.
- [57] El-Khattam W, Sidhu TS. Restoration of directional overcurrent relay coordination in distributed generation systems utilizing fault current limiter. *Power Delivery, IEEE Transactions on*. 2008;23:576-85.
- [58] Li WL, Monti A, Ponci F. Fault Detection and Classification in Medium Voltage DC Shipboard Power Systems With Wavelets and Artificial Neural Networks. *Instrumentation and Measurement, IEEE Transactions on* 2014;63:2651-65.
- [59] Cuzner R, MacFarlin D, Clinger D, Rumney M, Castles G. Circuit breaker protection considerations in power converter-fed DC Systems. *Electric Ship Technologies Symposium, 2009 ESTS 2009 IEEE2009*. p. 360-7.
- [60] Gopalan SA, Sreeram V, Iu HH. A review of coordination strategies and protection schemes for microgrids. *Renewable and Sustainable Energy Reviews*. 2014;32:222-8.
- [61] Gas insulated MV circuit-breakers. In: ABB, editor. *Medium voltage products: [www.abb.com](http://www.abb.com)*; 2013.
- [62] Baran ME, Mahajan NR. Overcurrent protection on voltage-source-converter-based multiterminal DC distribution systems. *Power Delivery, IEEE Transactions on*. 2007;22:406-12.
- [63] M. Callavik AB, J. Häfner, B. Jacobson. The Hybrid HVDC Breaker: An innovation breakthrough enabling reliable HVDC grids. 2012 ed. [www.abb.com](http://www.abb.com) ABB Grid Systems, 2012; 2012.
- [64] Flourentzou N, Agelidis VG, Demetriades GD. VSC-Based HVDC Power Transmission Systems: An Overview. *Power Electronics, IEEE Transactions on*. 2009;24:592-602.
- [65] Yazdanpanahi H, Li YW, Xu W. A new control strategy to mitigate the impact of inverter-based DGs on protection system. *Smart Grid, IEEE Transactions on*. 2012;3:1427-36.
- [66] Ma J, Li J, Wang Z. An adaptive distance protection scheme for distribution system with distributed generation. *Critical Infrastructure (CRIS), 2010 5th International Conference on: IEEE; 2010*. p. 1-4.
- [67] Sortomme E, Venkata S, Mitra J. Microgrid protection using communication-assisted digital relays. *Power Delivery, IEEE Transactions on*. 2010;25:2789-96.
- [68] Tang J, McLaren P. A wide area differential backup protection scheme for shipboard application. *Power Delivery, IEEE Transactions on*. 2006;21:1183-90.
- [69] Dambhare S, Soman S, Chandorkar M. Adaptive current differential protection schemes for transmission-line protection. *Power Delivery, IEEE Transactions on*. 2009;24:1832-41.
- [70] Zamani A, Sidhu T, Yazdani A. A strategy for protection coordination in radial distribution networks with distributed generators. *Power and Energy Society General Meeting, 2010 IEEE: IEEE; 2010*. p. 1-8.
- [71] Jones D, Kumm J. Future distribution feeder protection using directional overcurrent elements. *Rural Electric Power Conference (REPC), 2013 IEEE: IEEE; 2013*. p. B4-1-B4-7.
- [72] Jiadong H, Zeyun Z, Xiaobo D. The Influence of the Distributed Generation to the Distribution Network Line Protection and Countermeasures. *Physics Procedia*. 2012;24:205-10.
- [73] Zhang Y, Dougal RA. Novel dual-FCL connection for adding distributed generation to a power distribution utility. *Applied Superconductivity, IEEE Transactions on*. 2011;21:2179-83.
- [74] Hussain B, Sharkh S, Hussain S, Abusara M. An Adaptive Relaying Scheme for Fuse Saving in Distribution Networks With Distributed Generation. 2013.
- [75] Ghanbari T, Farjah E. Development of an Efficient Solid-State Fault Current Limiter for Microgrid. *Power Delivery, IEEE Transactions on*. 2012;27:1829-34.
- [76] Nimpitiwan N, Heydt GT, Ayyanar R, Suryanarayanan S. Fault current contribution from synchronous machine and inverter based distributed generators. *Power Delivery, IEEE Transactions on*. 2007;22:634-41.
- [77] Basso TS, DeBlasio R. IEEE 1547 series of standards: interconnection issues. *Power Electronics, IEEE Transactions on*. 2004;19:1159-62.
- [78] Brahma SM, Girgis AA. Development of adaptive protection scheme for distribution systems with high penetration of distributed generation. *Power Delivery, IEEE Transactions on*. 2004;19:56-63.
- [79] Javadian S, Haghifam M-R, Rezaei N. A fault location and protection scheme for distribution systems in presence of dg using MLP neural networks. *Power & Energy Society General Meeting, 2009 PES'09 IEEE: IEEE; 2009*. p. 1-8.
- [80] Dewadasa M, Ghosh A, Ledwich G, Wishart M. Fault isolation in distributed generation connected distribution networks. *IET generation, transmission & distribution*. 2011;5:1053-61.

- [81] Conti S, Nicotra S. Procedures for fault location and isolation to solve protection selectivity problems in MV distribution networks with dispersed generation. *Electric Power Systems Research*. 2009;79:57-64.
- [82] Ma J, Wang X, Zhang Y, Yang Q, Phadke A. A novel adaptive current protection scheme for distribution systems with distributed generation. *International Journal of Electrical Power & Energy Systems*. 2012;43:1460-6.
- [83] Amraee T. Coordination of directional overcurrent relays using seeker algorithm. *Power Delivery, IEEE Transactions on*. 2012;27:1415-22.
- [84] Najy WK, Zeineldin HH, Woon WL. Optimal protection coordination for microgrids with grid-connected and islanded capability. *Industrial Electronics, IEEE Transactions on*. 2013;60:1668-77.
- [85] Zayandehroodi H, Mohamed A, Shareef H, Farhoodnea M. A novel neural network and backtracking based protection coordination scheme for distribution system with distributed generation. *International Journal of Electrical Power & Energy Systems*. 2012;43:868-79.
- [86] Rezaei N, Haghifam M-R. Protection scheme for a distribution system with distributed generation using neural networks. *International Journal of Electrical Power & Energy Systems*. 2008;30:235-41.
- [87] Javadian SAM, Haghifam MR, Bathaee SMT, Fotuhi Firoozabad M. Adaptive centralized protection scheme for distribution systems with DG using risk analysis for protective devices placement. *International Journal of Electrical Power & Energy Systems*. 2013;44:337-45.
- [88] Mirsaedi S, Mat Said D, Wazir Mustafa M, Hafiz Habibuddin M, Ghaffari K. An analytical literature review of the available techniques for the protection of micro-grids. *International Journal of Electrical Power & Energy Systems*. 2014;58:300-6.
- [89] Wan H, Li K, Wong K. An adaptive multiagent approach to protection relay coordination with distributed generators in industrial power distribution system. *Industry Applications, IEEE Transactions on*. 2010;46:2118-24.
- [90] Zamani MA, Yazdani A, Sidhu TS. A communication-assisted protection strategy for inverter-based medium-voltage microgrids. *Smart Grid, IEEE Transactions on*. 2012;3:2088-99.
- [91] Perera N, Rajapakse A, Buchholzer T. Isolation of faults in distribution networks with distributed generators. *Power Delivery, IEEE Transactions on*. 2008;23:2347-55.
- [92] Laaksonen HJ. Protection principles for future microgrids. *Power Electronics, IEEE Transactions on*. 2010;25:2910-8.
- [93] Mackiewicz R. Overview of IEC 61850 and Benefits. *Power Systems Conference and Exposition, 2006 PSCE'06 2006 IEEE PES: IEEE; 2006*. p. 623-30.
- [94] CODE P. Communication networks and systems in substations—Part 5: Communication requirements for functions and device models. 2003.
- [95] Vanfretti L, Chenine M, Almas MS, Leelarui R, Angquist L, Nordstrom L. SmarTS Lab—A laboratory for developing applications for WAMPAC Systems. *Power and Energy Society General Meeting, 2012 IEEE: IEEE; 2012*. p. 1-8.
- [96] Ishchenko D, Oudalov A, Stoupi J. Protection coordination in active distribution grids with IEC 61850. *Transmission and Distribution Conference and Exposition (T&D), 2012 IEEE PES: IEEE; 2012*. p. 1-6.
- [97] Zadeh HK, Manjrekar M. A novel IEC 61850-based distribution line/cable protection scheme design. *Innovative Smart Grid Technologies (ISGT), 2012 IEEE PES: IEEE; 2012*. p. 1-6.
- [98] Baran M, Mahajan NR. PEBB based DC system protection: opportunities and challenges. *Transmission and Distribution Conference and Exhibition, 2005/2006 IEEE PES: IEEE; 2006*. p. 705-7.
- [99] Peralta J, Saad H, Denetiere S, Mahseredjian J, Nguéfeu S. Detailed and averaged models for a 401-level MMC–HVDC system. *Power Delivery, IEEE Transactions on*. 2012;27:1501-8.
- [100] Friedrich K. Modern HVDC PLUS application of VSC in Modular Multilevel Converter topology. *Industrial Electronics (ISIE), 2010 IEEE International Symposium on: IEEE; 2010*. p. 3807-10.
- [101] Cairolì P, Kondratiev I, Dougal RA. Coordinated control of the bus tie switches and power supply converters for fault protection in dc microgrids. *Power Electronics, IEEE Transactions on*. 2013;28:2037-47.
- [102] Tang L, Ooi B-T. Locating and isolating DC faults in multi-terminal DC systems. *Power Delivery, IEEE Transactions on*. 2007;22:1877-84.
- [103] Shi J, Tang Y, Wang C, Zhou Y, Li J, Ren L, et al. Active superconducting DC fault current limiter based on flux compensation. *Physica C: Superconductivity*. 2006;442:108-12.
- [104] Ghisla U, Kondratiev I, Dougal R. Protection of medium voltage DC power systems against ground faults and negative incremental impedances. *IEEE SoutheastCon 2010 (SoutheastCon), Proceedings of the: IEEE; 2010*. p. 259-63.
- [105] Mehdi Monadi CK-C, Alvaro Luna, Jose Ignacio Candela, Pedro Rodriguez. A Protection Strategy for Fault Detection and Location for Multi-Terminal MVDC Distribution Systems with Renewable Energy Systems. *ICRERA2014, Milwaukee, USA: IEEE; 2014*.
- [106] Farhadi M, Mohammed O. Event-Based Protection Scheme for a Multiterminal Hybrid DC Power System.
- [107] Yuan C, Haj-ahmed M, Illindala M. Protection Strategies for Medium Voltage Direct Current Microgrid at a Remote Area Mine Site.
- [108] Fletcher S, Norman P, Galloway S, Burt G. Fault detection and location in DC systems from initial di/dt measurement. *Euro Tech Con Conference*. 2012.
- [109] Cinieri E, Fumi A, Salvatori V, Spalvieri C. A New High-Speed Digital Relay Protection of the 3-kVdc Electric Railway Lines. *Power Delivery, IEEE Transactions on*. 2007;22:2262-70.
- [110] Emhemed AA, Burt GM. An Advanced Protection Scheme for Enabling an LVDC Last Mile Distribution Network. 2014.
- [111] Christopher E, Sumner M, Thomas DWP, Xiaohui W, de Wildt F. Fault Location in a Zonal DC Marine Power System Using Active Impedance Estimation. *Industry Applications, IEEE Transactions on*. 2013;49:860-5.
- [112] Descloux J, Raison B, Curis J-B. Protection strategy for undersea mtcd grids. *PowerTech (POWERTECH), 2013 IEEE Grenoble: IEEE; 2013*. p. 1-6.
- [113] Hajian M, Zhang L, Jovcic D. DC Transmission Grid with Low Speed Protection using Mechanical DC Circuit Breakers. *Power Delivery, IEEE Transactions on*. 2014;PP:1-.
- [114] Fletcher SDA, Norman PJ, Fong K, Galloway SJ, Burt GM. High-Speed Differential Protection for Smart DC Distribution Systems. *Smart Grid, IEEE Transactions on*. 2014;5:2610-7.

- [115] Li W, Luo M, Monti A, Ponci F. Wavelet based method for fault detection in medium voltage DC shipboard power systems. Instrumentation and Measurement Technology Conference (I2MTC), 2012 IEEE International: IEEE; 2012. p. 2155-60.
- [116] Cheng J, Guan M, Tang L, Huang H. A fault location criterion for MTDC transmission lines using transient current characteristics. International Journal of Electrical Power & Energy Systems. 2014;61:647-55.
- [117] Joorabian M, Taleghani Asl SMA, Aggarwal RK. Accurate fault locator for EHV transmission lines based on radial basis function neural networks. Electric Power Systems Research. 2004;71:195-202.
- [118] Chanda NK, Fu Y. ANN-based fault classification and location in MVDC shipboard power systems. North American Power Symposium (NAPS), 2011: IEEE; 2011. p. 1-7.
- [119] Chang C, Kumar S, Liu B, Khambadkone A. Real-time detection using wavelet transform and neural network of short-circuit faults within a train in DC transit systems. Electric Power Applications, IEE Proceedings-. 2001;148:251-6.
- [120] Azizi S, Afsharnia S, Sanaye-Pasand M. Fault location on multi-terminal DC systems using synchronized current measurements. International Journal of Electrical Power & Energy Systems. 2014;63:779-86.
- [121] Xiaqing L, Shuyou G, Yiming Z, Yunhua L, Shengtao F. Research on Fault Diagnosis and Protect Model for DC Traction Power Supply System Based on Traveling Wave Theory. Robotics, Automation and Mechatronics, 2006 IEEE Conference on 2006. p. 1-5.
- [122] Xiaolei L, Osman AH, Malik OP. Hybrid Traveling Wave/Boundary Protection for Monopolar HVDC Line. Power Delivery, IEEE Transactions on. 2009;24:569-78.