



UNIVERSITAT POLITÈCNICA DE CATALUNYA
BARCELONATECH

Escola Superior d'Enginyeries Industrial,
Aeroespacial i Audiovisual de Terrassa

Design of a lightweight rover with adapted suspension for lunar exploration

Document:
Appendix

Author:
Daniel Fernández Torner

Director - Coodirector:
Carlos Gustavo Díaz González

Degree:
Bachelor's degree in Aerospace Vehicles Engineering

Term:
Autumn, 2021.

BACHELOR FINAL THESIS

Contents

| | |
|--|----------|
| List of Figures | 1 |
| A Appendix | 3 |
| A.1 Main body model plan | 4 |
| A.2 Wheel model plan | 5 |
| A.3 Suspension model plan | 6 |
| A.4 Main body design gallery | 7 |
| A.5 Wheel design gallery | 9 |
| A.6 Suspension design gallery | 11 |
| A.7 Rover final design gallery | 12 |

List of Figures

| | | |
|------|---|----|
| A.1 | Rover's concept design. Own source via <i>SolidWorks</i> | 3 |
| A.2 | Main body design concept, view 1. Own source via <i>SolidWorks</i> | 7 |
| A.3 | Main body design concept, view 2. Own source via <i>SolidWorks</i> | 7 |
| A.4 | Main body design concept, view 3. Own source via <i>SolidWorks</i> | 8 |
| A.5 | Wheel model concept design, view 1. Own source via <i>SolidWorks</i> | 9 |
| A.6 | Wheel model concept design, view 2. Own source via <i>SolidWorks</i> | 9 |
| A.7 | Wheel model concept design, view 3. Own source via <i>SolidWorks</i> | 10 |
| A.8 | Suspension model concept design, view 1. Own source via <i>SolidWorks</i> | 11 |
| A.9 | Suspension model concept design, view 2. Own source via <i>SolidWorks</i> | 11 |
| A.10 | Suspension model concept design, view 3. Own source via <i>SolidWorks</i> | 11 |
| A.11 | Rover final design concept, view 1. Own source via <i>SolidWorks</i> | 12 |
| A.12 | Rover final design concept, view 2. Own source via <i>SolidWorks</i> | 12 |
| A.13 | Rover final design concept, view 3. Own source via <i>SolidWorks</i> | 13 |

A | Appendix

The following appendix sections will show the rover's model plans and its views on *Solidworks*.

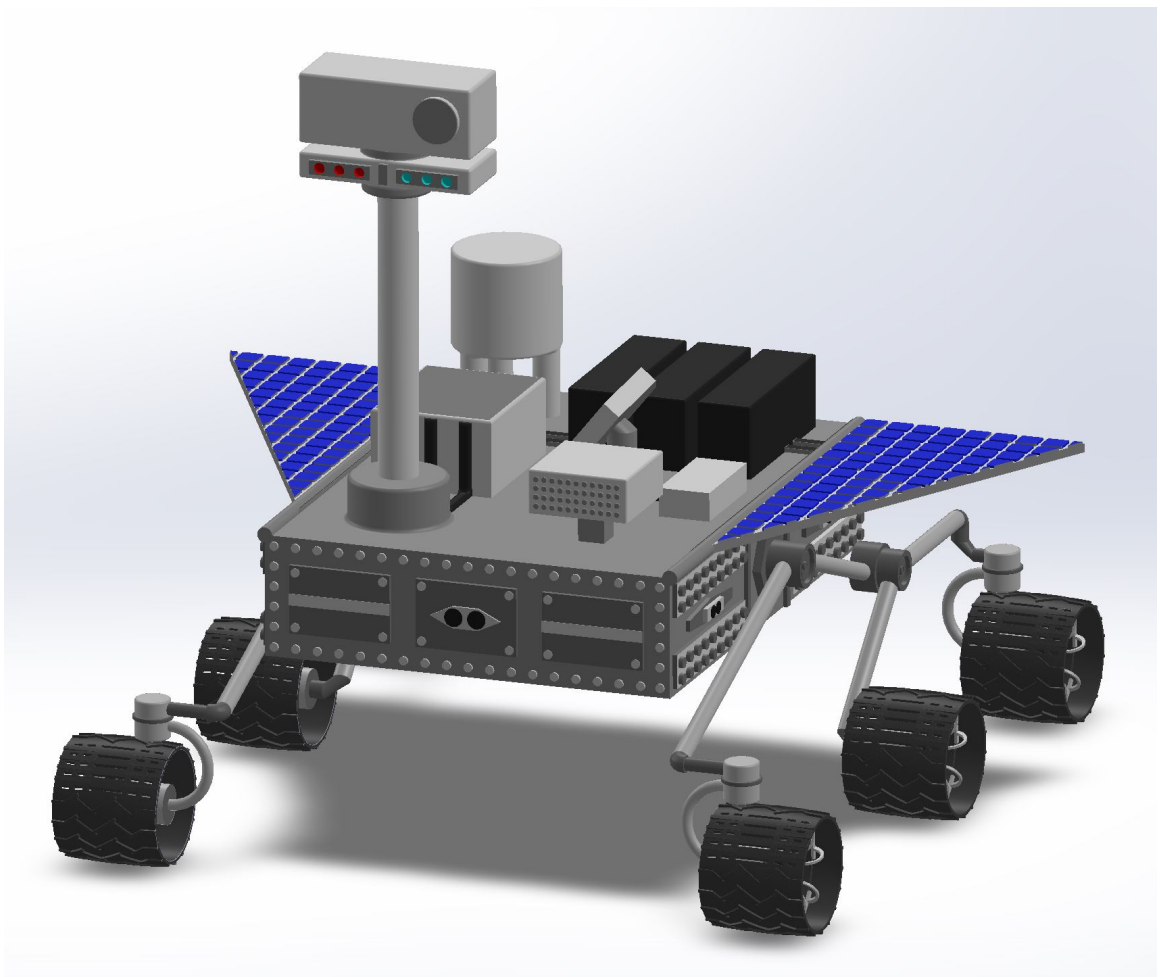
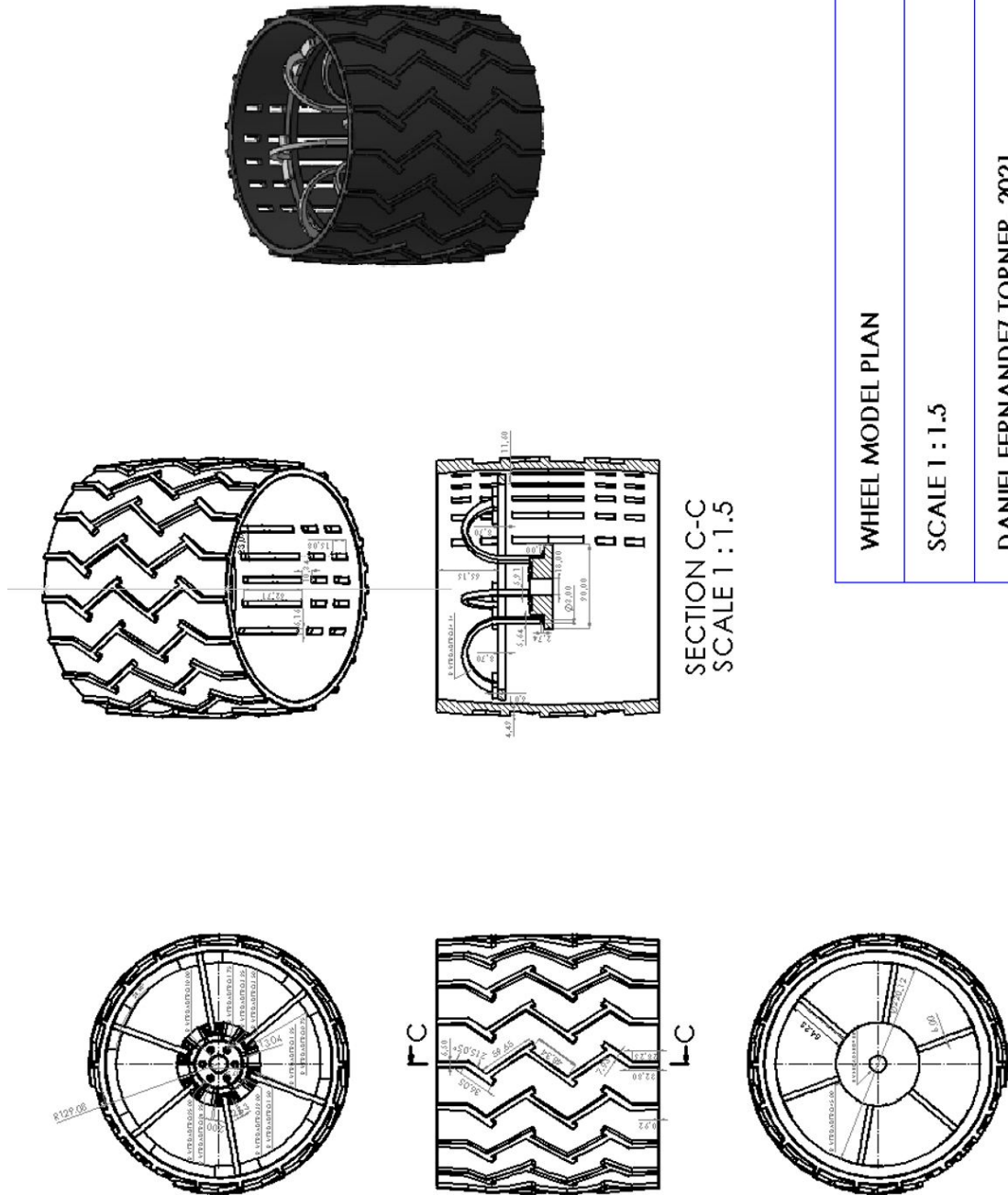

Figure A.1: Rover's concept design. Own source via *SolidWorks*.

A.2 Wheel model plan



| |
|---|
| WHEEL MODEL PLAN |
| SCALE 1:1.5 |
| DANIEL FERNANDEZ TORNER, 2021 |
| TFG, UNIVERSITAT POLITÈCNICA DE CATALUNYA |

A.3 Suspension model plan

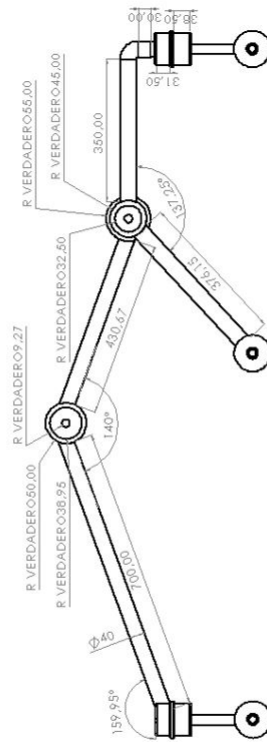
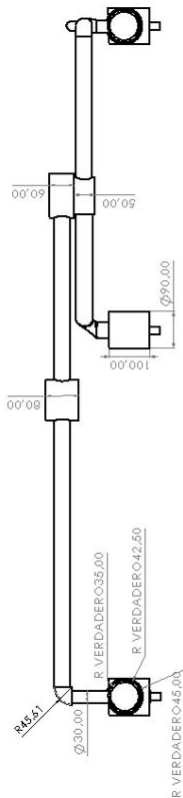
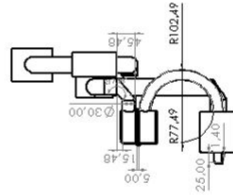
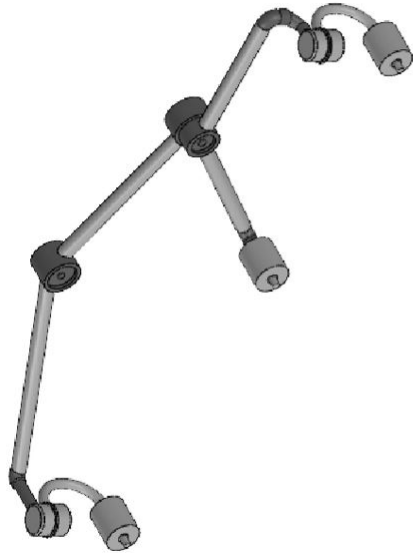

SUSPENSION MODEL PLAN

SCALE 1 : 3.5

DANIEL FERNANDEZ TORNER, 2021

TFG, UNIVERSITAT POLITÈCNICA DE CATALUNYA

A.4 Main body design gallery

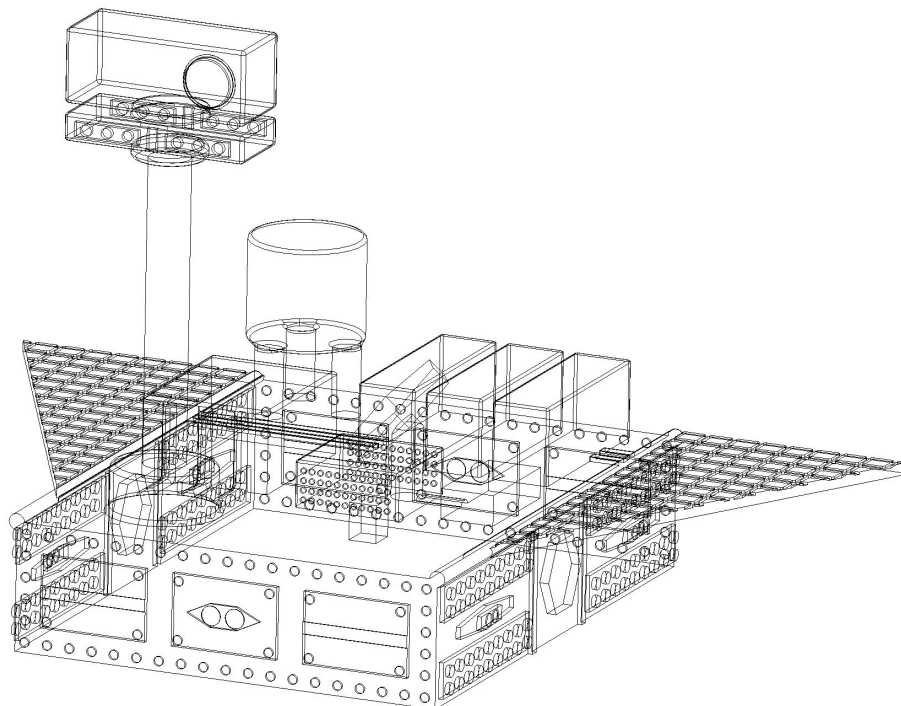

Figure A.2: Main body design concept, view 1. Own source via *SolidWorks*.

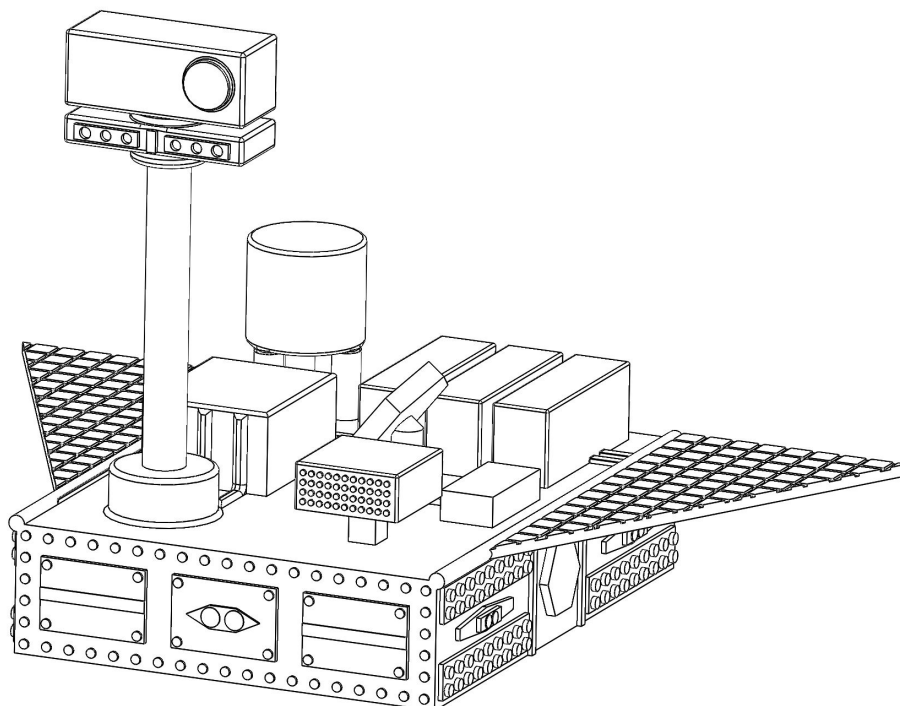

Figure A.3: Main body design concept, view 2. Own source via *SolidWorks*.

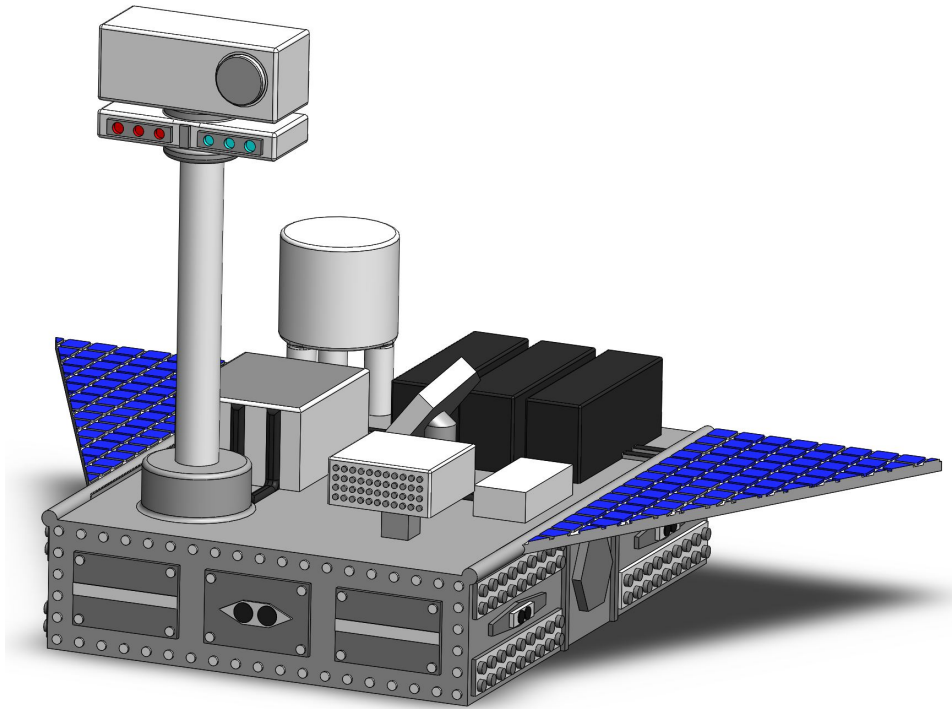

Figure A.4: Main body design concept, view 3. Own source via *SolidWorks*.

A.5 Wheel design gallery

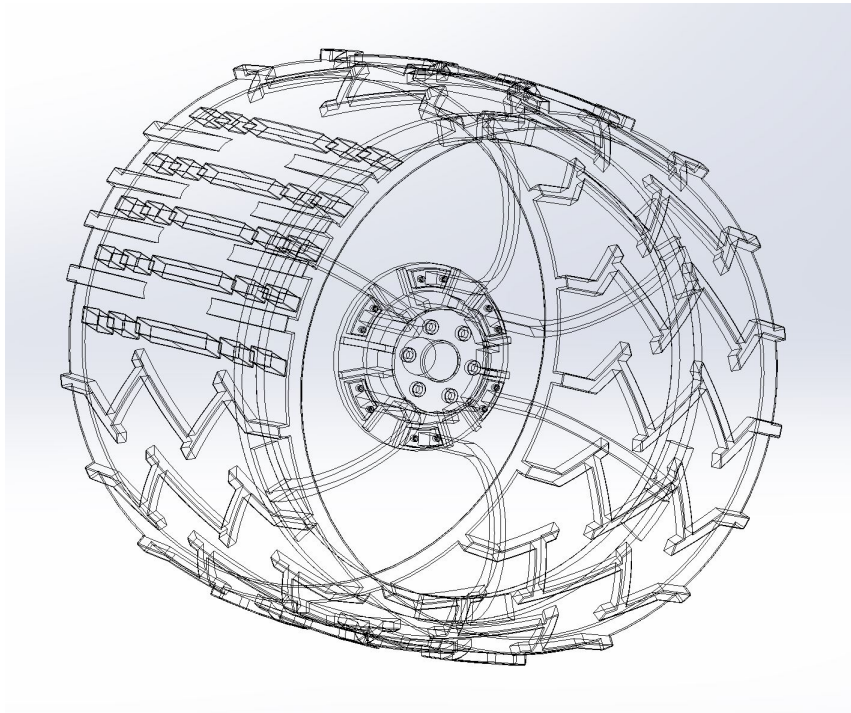

Figure A.5: Wheel model concept design, view 1. Own source via *SolidWorks*.

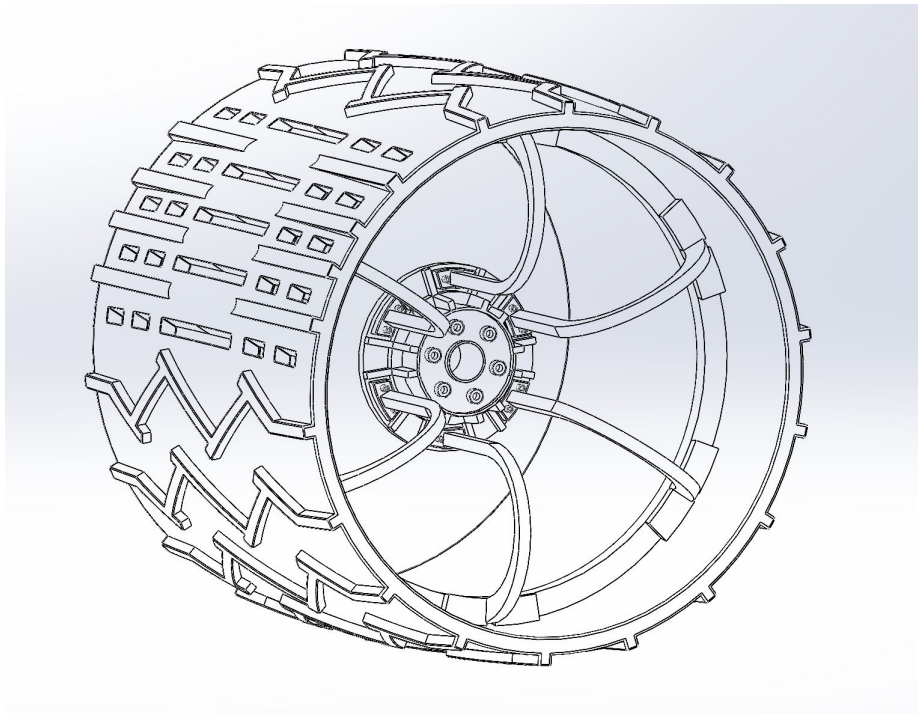

Figure A.6: Wheel model concept design, view 2. Own source via *SolidWorks*.

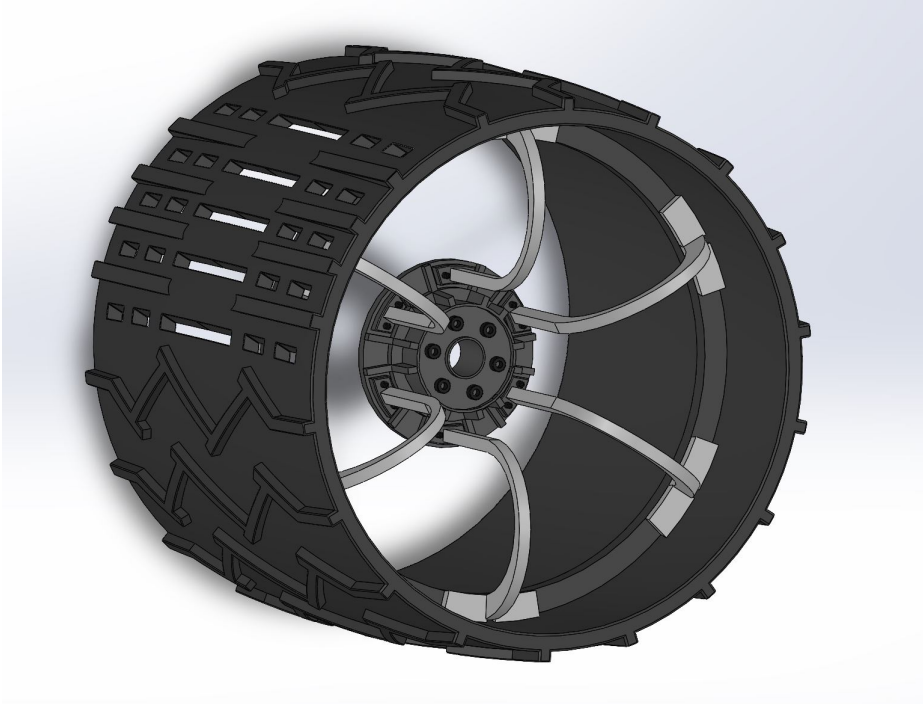

Figure A.7: Wheel model concept design, view 3. Own source via *SolidWorks*.

A.6 Suspension design gallery

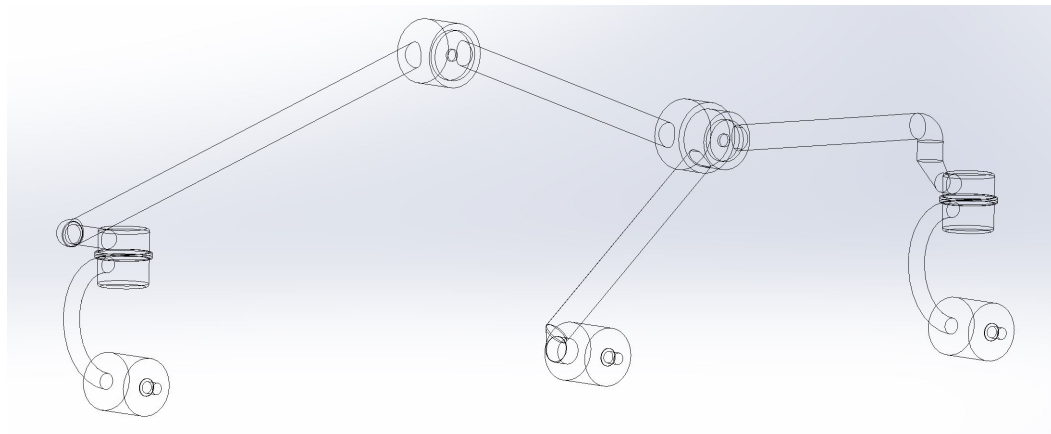

Figure A.8: Suspension model concept design, view 1. Own source via *SolidWorks*.

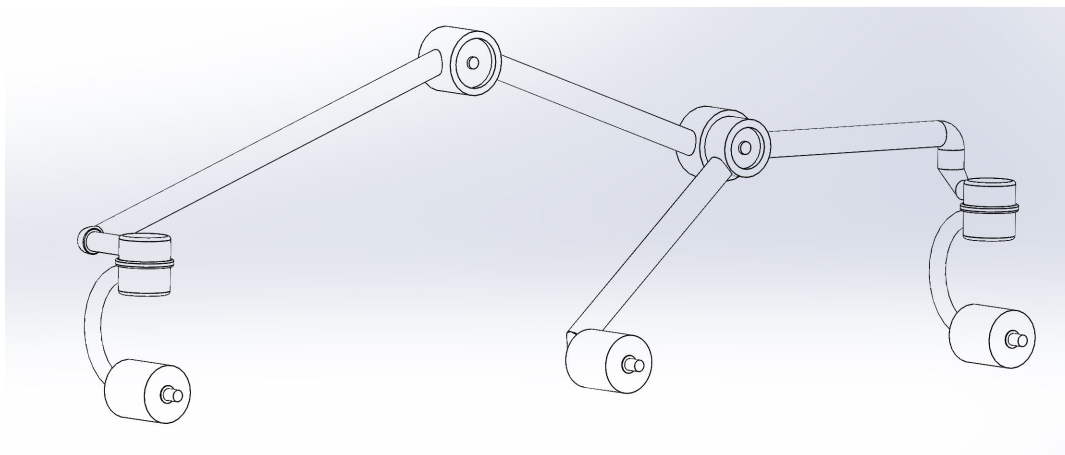

Figure A.9: Suspension model concept design, view 2. Own source via *SolidWorks*.

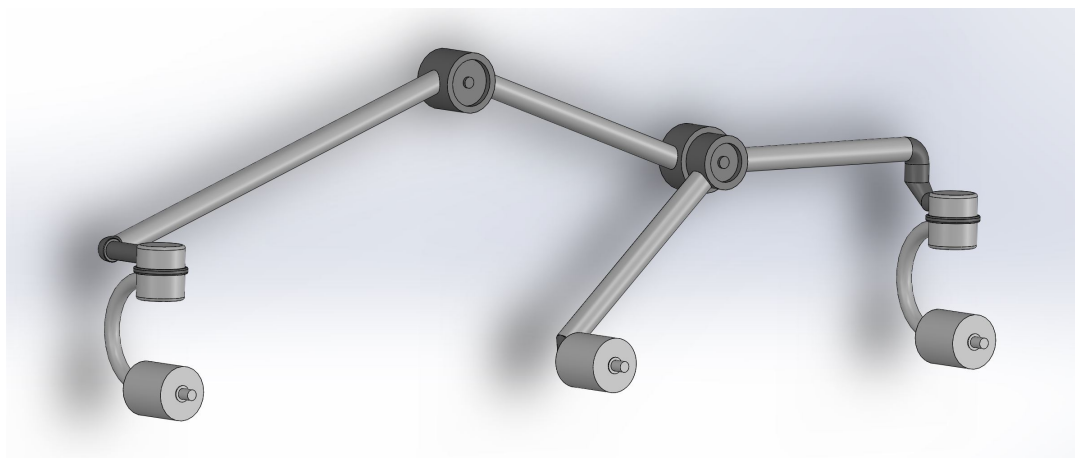

Figure A.10: Suspension model concept design, view 3. Own source via *SolidWorks*.

A.7 Rover final design gallery

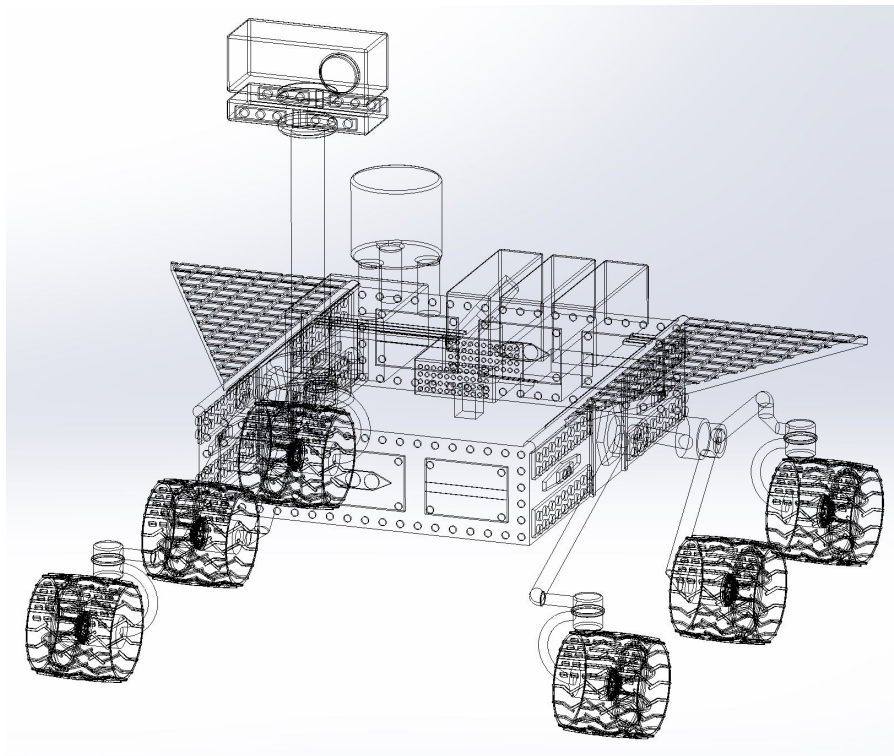

Figure A.11: Rover final design concept, view 1. Own source via *SolidWorks*.

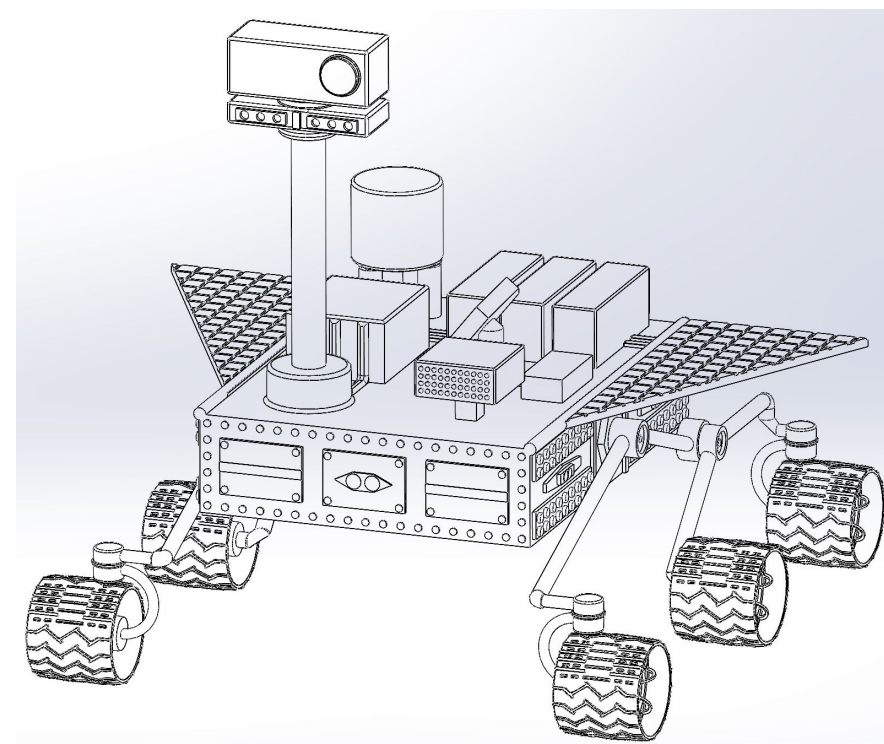

Figure A.12: Rover final design concept, view 2. Own source via *SolidWorks*.

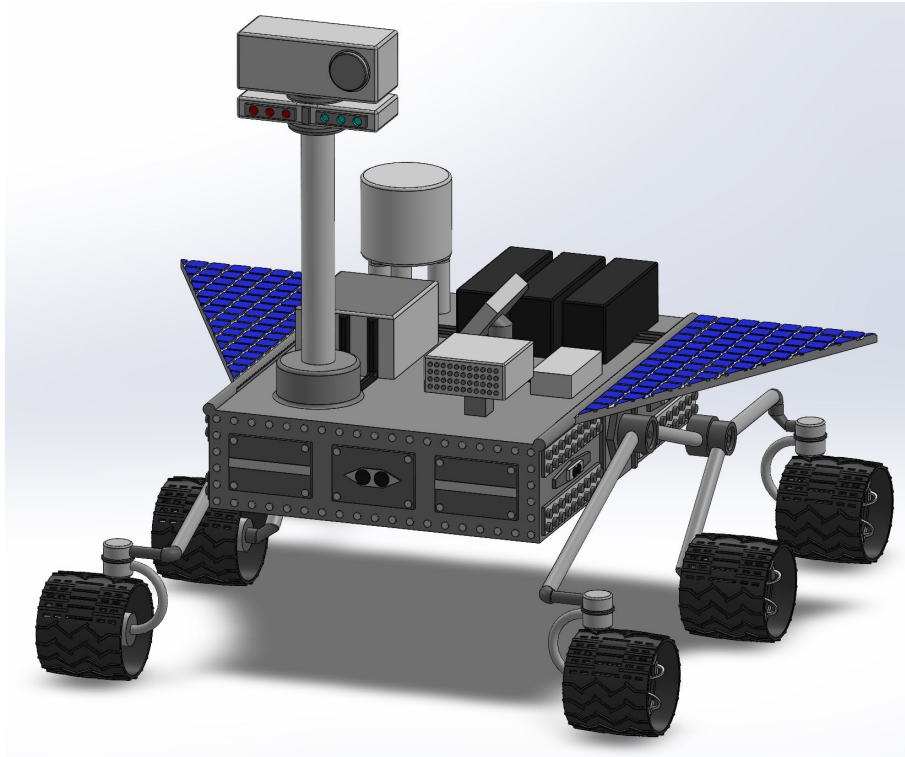

Figure A.13: Rover final design concept, view 3. Own source via *SolidWorks*.

