



UNIVERSITAT POLITÈCNICA
DE CATALUNYA

**GeoPlex experimental setup:
Generator and converter**

**Arnau Dòria Cerezo, Carles Batlle Arnau,
Enric Fossas Colet**

*ACES: Control Avançat de Sistemes d'Energia
IST_2001_34166*

*IOC-DT-P-2006-1
Gener 2006*

Institut d'Organització i Control
de Sistemes Industrials



GeoPlex experimental setup: Generator and converter.

Arnau Dòria-Cerezo, Carles Batlle and Enric Fossas
Universitat Politècnica de Catalunya

September, 2005

Abstract

The experimental setup of the Flywheel Energy Storage System is presented. The system is made of a doubly-fed induction machine coupled to a flywheel and a back-to-back converter.

1 Introduction

The system studied in this workpackage is an autonomous energy-switching system that regulates the energy flow between a local prime mover (a flywheel) and the electrical power network, in order to satisfy the demand of a time-varying electrical load. This system, used in the CERN (Centre Européen pour la Recherche Nucléaire) to store electrical energy for the particle accelerator or at the Okinawa Electric Power Company [1], has been also studied in [1]. The main goal of the system is, basically, to store kinetic energy into a flywheel and deliver it when an external load requires a high energy flow.

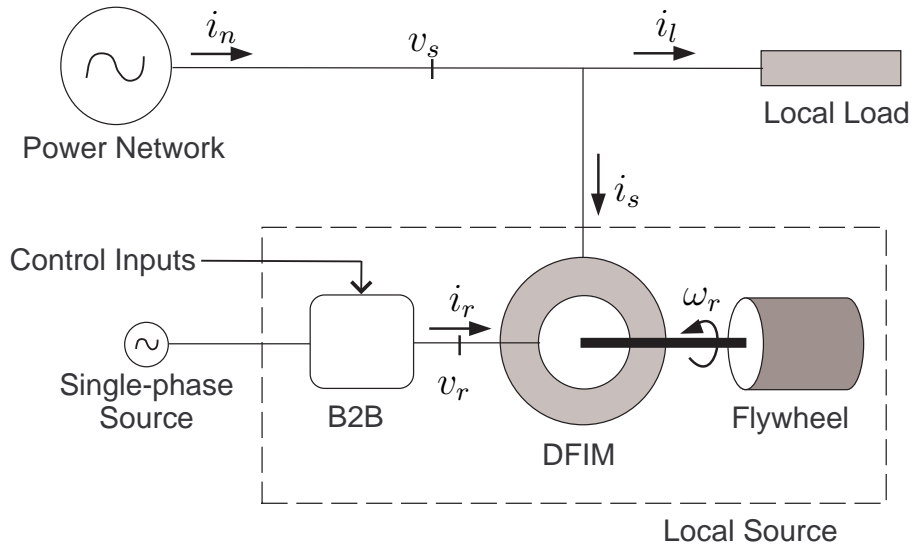

Figure 1: Doubly fed induction machine coupled to a flywheel, controlled by a back-to-back converter and connected to a power network and a load.

The system (see Figure 1) is composed by a doubly-fed induction machine (DFIM) coupled to a flywheel and controlled through the rotor windings by a back-to-back converter (B2B). This is the most common control architecture of the DFIM [1][6][8][9][10][11][14][15], typically achieved

by means of a B2B. In a case that the AC source of the B2B is connected to the 3-phase power grid, this architecture is also known as Scherbius Drive [8], *i.e.* the power converter is in a closed-loop with the DFIM. In practice, due to the fact that the power flowing through the power converter is smaller than the power flowing to the DFIM stator side, it is common to neglect this *feedback* connection.

The DFIM is controlled through the rotor windings port ($v_r, i_r \in \mathbb{R}^3$, where v and i are a three-phase voltage and current variables, and subindex r refers to the rotor). It is coupled to an energy-storing flywheel with port variables (τ_e electrical torque, ω mechanical speed). An electrical network modelled by an ideal AC voltage source with port variables ($v_n, i_n \in \mathbb{R}^3$ subindex n refers to the network variables), and a generic electrical three-phase load, represented by its impedance Z_l , is connected to the stator port variables ($v_s, i_s \in \mathbb{R}^3$).

As mentioned above, the main objective of the system is to supply the required power to the load with a high network power factor. Depending on the load demands, the DFIM acts as an energy-switching device between the flywheel and the electrical power network. The control problem is to optimally regulate the power flow.

These goals, assuming a maximal active power of the network P_n^{MAX} , can be summarized as follows:

- **To supply** the extra energy required by the load. Notice that this objective concerns the active power, and considering a constant grid voltage, $V_n = ct$, this requirement is achieved by the stator currents.
- **To store** kinetic energy in the flywheel when the load does not require all the grid power.
- **To compensate** the power factor ($\cos \phi$), *i.e.*, the whole system (load and local source acts as a pure resistor). That is $\cos \phi \sim 0$, or, in other words assuming, sinusoidal waveform and an equilibrated system, this objective can be written as $Q_n \sim 0$.

This control problem can be achieved by commuting between different steady-state regimes. The switching strategy was studied in [2].

2 The doubly-fed induction machine

Doubly-fed induction machines (DFIM) form a class of induction machines which have become very popular for renewable energy applications. They have been proposed in the literature, among other applications, for wind-turbine generators [8][13], hybrid engines [3] or high performance storage systems [1][2]. The attractiveness of the DFIM stems primarily from its ability to handle large speed variations around the synchronous speed (see [11] for an extended literature survey and discussion). Another advantage is that the power electronic equipment to control the machine only has to handle a fraction (maximum 20 – 30%) of the total power [12]. Therefore, the losses in the power electronic converter can be reduced, compared to a system where the converter has to handle the total power. In addition, the cost of the converter becomes lower.

Figure 2 shows the DFIM coupled to a flywheel. In order to increase the performance of the experimental setup the flywheel is split into two different inertias.

The DFIM is a 1.1kW machine De Lorenzo DL 1022K, with the following parameters: number of poles $n = 2$, voltage fed 220/380V (Δ/Y), nominal current 4.8/2.8A (Δ/Y), stator resistance $R_s = 4.92\Omega$, rotor resistance $R_r = 4.42\Omega$, mutual inductance $L_{sr} = 0.71H$, stator inductance $L_s = 0.725H$, rotor inductance $L_r = 0.715H$, mechanical damping $B_r = 0.005Kgm^2s^{-1}$ and inertia $J_m = 0.00512Kgm^2$.

The flywheel is a De Lorenzo DL-10410 with $J = 0.055Kgm^2$ each inertia.

3 The back-to-back converter

Electronic power converters [4] are devices able to deliver electrical energy in a suitable way for the applications, *i.e.*, with prescribed frequency, voltage amplitude or any other specification. They

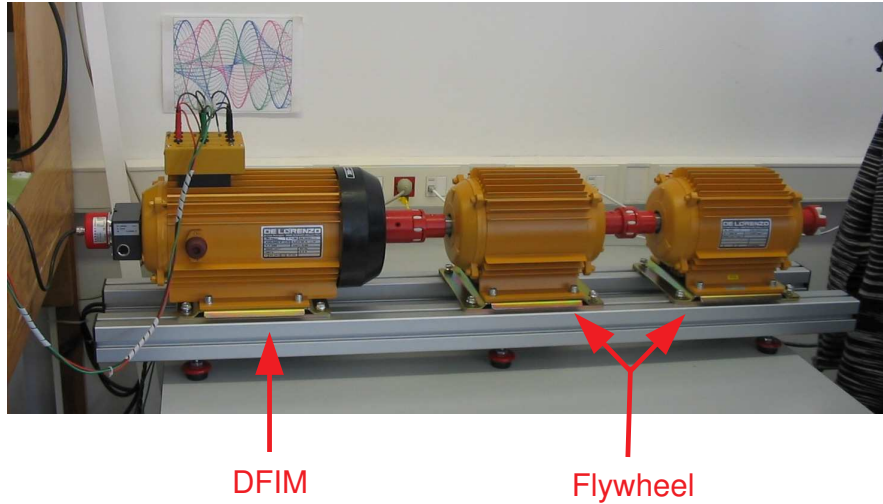

Figure 2: The DFIM coupled to a flywheel.

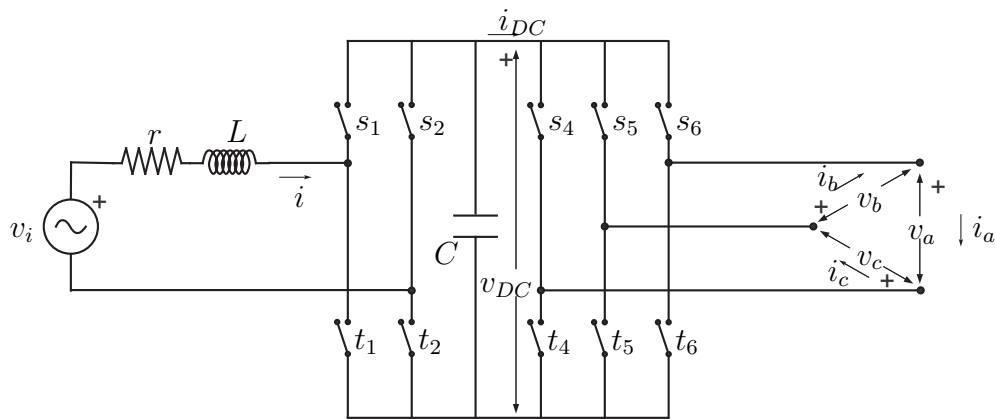

Figure 3: Back-to-back converter.

do the trick by periodically storing the energy in inductors and capacitors before releasing it in the desired form; in a given period the converter goes through a series of topological circuit changes by means of controlled switches (for instance IGBT switches).

The back-to-back converter consists of two converters, namely, machine-side converter and grid-side converter, that are connected "back-to-back". Between the two converters a dc-link capacitor is placed, as energy storage, in order to keep the voltage variations (or ripple) in the dc-link voltage small. With the machine-side converter it is possible to control the torque or the speed of the DFIM and also the power factor at the stator terminals, while the main objective for the grid-side converter is to keep the dc-link voltage constant.

Figure 3 shows the back-to-back converter selected for this system. It differs from the typical topology in the grid-side converter; in this case the dc-link voltage is controlled by a single-phase boost rectifier instead of a three-phase rectifier. The machine-side converter is a three-phase dc/ac inverter. The whole converter has an ac single *input* and its *outputs* are three-phase PWM (pulse width modulation) voltages which feed the rotor windings of the electrical machine. This system can be split into two parts: a dynamical subsystem (the full bridge rectifier, containing the storage elements) and an static subsystem (the inverter, which from the energy point of view, acts like a

transformer).

A single-phase ac voltage source v_i provides the energy in the direct operation mode, L is the inductance, C is the capacitor of the dc-link, r takes into account all the resistance losses (inductor, source and switches), s_k and t_k ($k = 1, 2, 3, 5, 6$). Switch states take values in $\{-1, 1\}$ and t -switches are complementary to s -switches: $t_k = \bar{s}_k = -s_k$. Additionally, $s_2 = \bar{s}_1 = -s_1$.

One of the principal requirements is that the B2B converter has to allow a bidirectional power flow, since, depending on the operational specifications, the DFIM can extract energy through the rotor. This feature is achieved using IGBT switches instead of diodes and thyristors, which have a low cost and an easiest implementation in the experimental setup [7].

The back-to-back converter is depicted in Figure 4 and has the following parts:

- A full-bridge boost converter (depicted in Figure 4) with IGBT switches (Siemens BSM 25GD 100D) and parameters: $r = 0.1\Omega$, $L = 1\text{mH}$, $C = 4500\mu\text{F}$. The switching frequency of the converter is 20 KHz and a synchronous centered-pulse single-update pulse-width modulation strategy is used to map the controller's output to the IGBT gate signals.
- A 3-phase DC/AC inverter with a set of IGBT switches (1200 V, 100 A). The switching frequency of the inverter is 20 KHz and a synchronous centered-pulse single-update pulse-width modulation strategy is used to map the controller's output to the IGBT gate signals.
- The analog circuitry for the sensors: the AC main source, PMW and DC bus voltages and currents are sensed with isolation amplifiers. All the signals from the sensors pass through the corresponding gain conditioning stages to adapt their values to A/D converters.
- Control hardware and DSP implementation: the control algorithm can be implemented using the Analog Devices DSP-21116 and DSP-21992 processors. The processing core of this device runs at 100MHz and has a 32bit floating-point unit. The sampling rate of the A/D channels has been selected at 20KHz, the same as the switching frequency of the full-bridge system.
- The nominal RMS AC mains voltage is $V_s = 48.9\text{V RMS}$ and its nominal frequency is 50 Hz.

4 Interconnection and Control

The control algorithm is coded into a computer running with RTLinux (Real Time Linux), using RTiC-Lab (Real Time Controls Laboratory) [5].

The control hardware setup consists of:

- PC computer: Pentium IV, 1.8 GHz, 512MB RAM.
- A/D card: 3 PCI-DAS 4020/12 modules. Ultra High-Speed PCI-bus Compatible, 4-Channel, 12-Bit Analog Input Board with two Analog Output Channels and 24 Digital I/O Channels.
- PWM card: NuDAQ PCI-8133. 3-Channel quadrature encoder counters for a PCI PnP-bus and a 12-Bit PWM waveform generators.

Figure 5 shows the signal connection scheme between the system and the control hardware ¹.

References

- [1] H. Akagi and H. Sato. Control and performance of a doubly-fed induction machine intended for a flywheel energy storage system. *IEEE Trans. Power Electron.*, 17(1):109–116, 2002.

¹The processing hardware of another plant [3], called Joint System (JS), which shares some elements with ours (FW), is also displayed

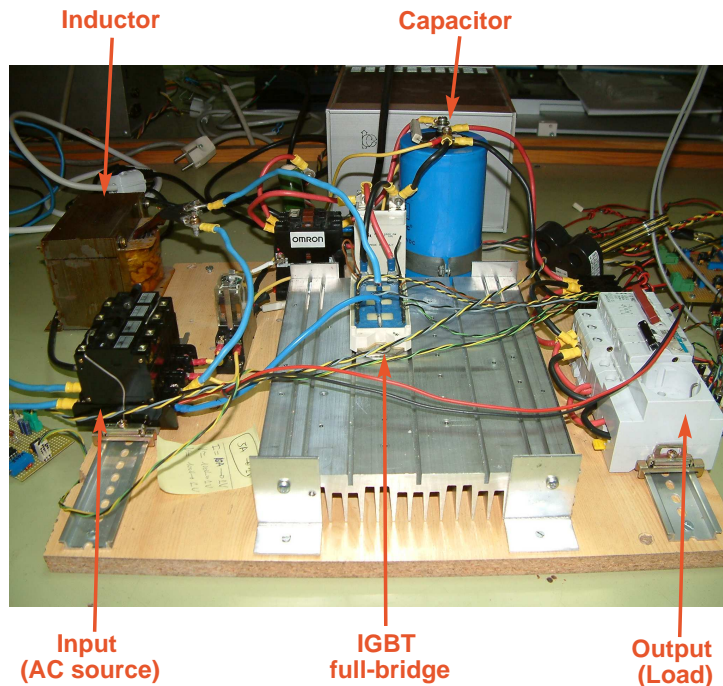
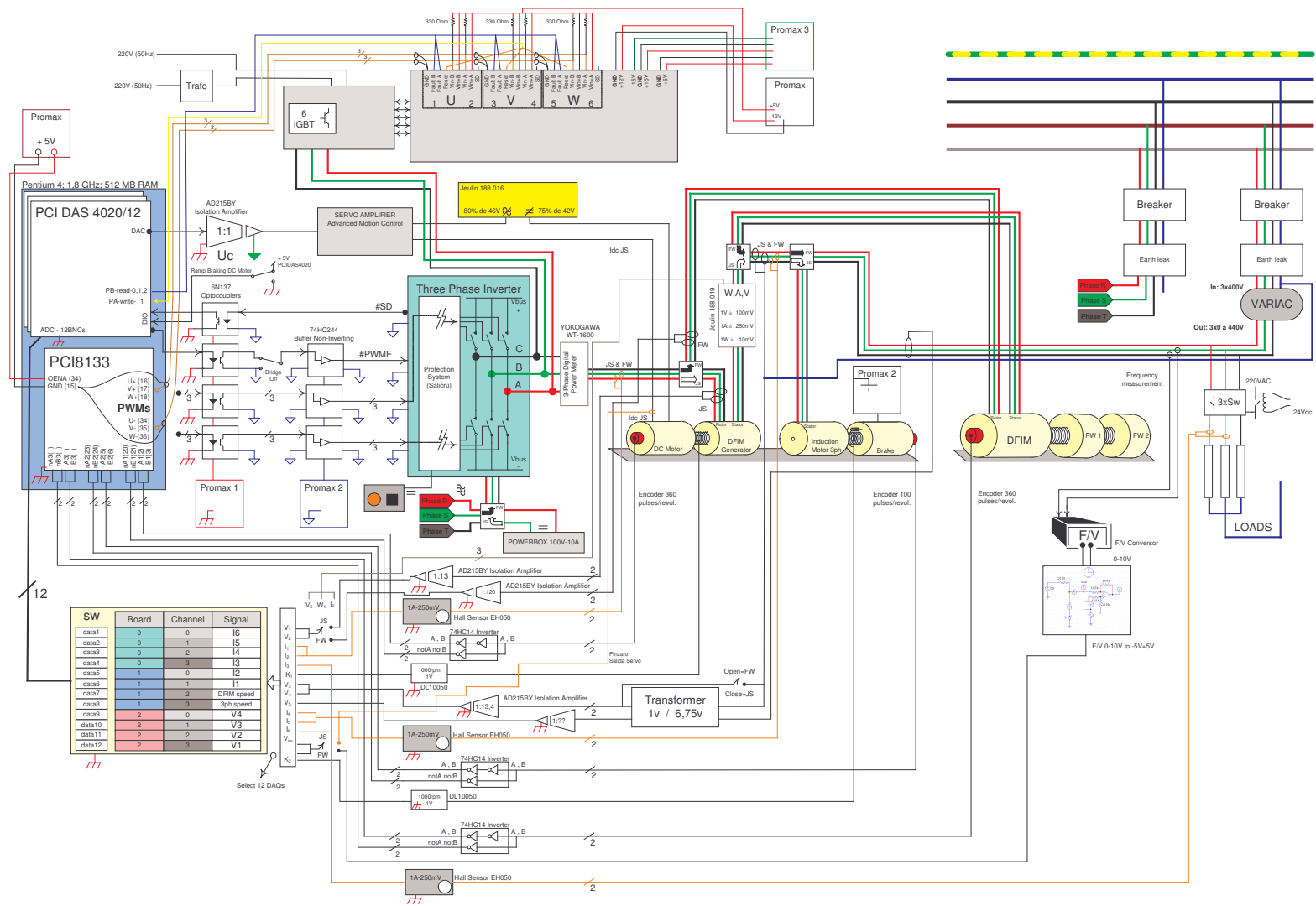

Figure 4: Experimental setup: full-bridge rectifier, DSP card, sensors, data acquisition.

- [2] C. Batlle, A. Dòria-Cerezo, and R. Ortega. Power Flow Control of a Doubly-Fed Induction Machine Coupled to a Flywheel. *European Journal of Control*, 11(3):209–221, 2005.
- [3] P. Caratozzolo. *Nonlinear control strategies of an isolated motion system with a double-fed induction generator*. PhD thesis, Universitat Politècnica de Catalunya, 2003.
- [4] R. Erickson. *Fundamentals of Power Electronics*. Kluwer, 1997.
- [5] E. Hilton. *Manual for the Real Time Controls Laboratory, RTiC-Lab*, 2000.
- [6] B. Hopfensperger, D. Atkinson, and R. Lakin. Stator-flux-oriented control of a doubly-fed induction machine with and without position encoder. In *IEE Proc. Electric Power Applications*, volume 147-4, pages 241–250, 2000.
- [7] S. Hui, H. Chung, and S. Yip. A bidirectional ac-dc power converter with power factor correction. *IEEE Transactions on Power Electronics*, 15(5):942–949, September 2000.
- [8] R. Peña, J. C. Clare, and G. M. Asher. Doubly fed induction generator using back-to-back pwm converters and its application to variable speed wind-energy generation. In *IEEE Proc. Electric Power Applications*, volume 143-5, pages 231–241, 1996.
- [9] R. Peña, J. C. Clare, and G. M. Asher. A doubly fed induction generator using back-to-back pwm converters supplying an isolated load from a variable speed wind turbine. In *IEEE Proc. Electric Power Applications*, volume 143-5, pages 380–387, 1996.
- [10] S. Peresada, A. Tilli, and A. Tonelli. Indirect Stator Flux-Oriented Output Feedback Control of a Doubly Fed Induction Machine. *IEEE Trans. Control Systems Technology*, 11(6):875–888, 2003.

Figure 5: Experimental setup: Interconnection scheme.



- [11] S. Peresada, A. Tilli, and A. Tonelli. Power control of a doubly fed induction machine via output feedback. *Control Engineering Practice*, 12:41–57, 2004.
- [12] A. Petersson. *Analisis, modeling and control of doubly-fed induction generators for wind turbines*. PhD thesis, Chalmers University of Technology, Sweden, 2005.
- [13] J. Slootweg, H. Polinder, and W. Kling. Dynamic modelling of a wind turbine with doubly fed induction generator. In *IEEE Power Engineering Society Summer Meeting 2001*, pages 644–649, 2001.
- [14] A. Tapia, G. Tapia, J. X. Ostolaza, and J. R. Sáenz. Modeling and control of a wind turbine driven doubly fed induction generator. *IEEE Trans. Energy Conversion*, 18:194–204, 2003.
- [15] L. Xu and W. Cheng. Torque and reactive power control of a doubly fed induction machine by position sensorless scheme. *IEEE Trans. Industry Applications*, 31(3):636–642, 1995.