

Analysis and Reduction of the Distortions Induced by Time-Domain Filtering Techniques in Network Analyzers

Ramir De Porrata-Dòria i Yagüe, Antoni Broquetas Ibars, *Member, IEEE*, and Luis Fernando Martínez

Abstract—The removal of isolation errors plays an essential role in the calibration process of radar scattering measurements. One of the most common techniques used for that purpose is time-domain filtering, also known as gating. In spite of the importance of gating techniques, however, little can be found about them in the open literature. This paper analyzes these techniques and provides the concepts required to develop them optimally. In addition, a new filtering method called chirp-z filtering (CZF) and techniques to remove remaining distortions are presented.

Index Terms—Radar cross sections, radar equipment, radar measurements, radar signal processing, time-frequency analysis.

I. INTRODUCTION

VECTOR network analyzers are often used to carry out radar cross-section (RCS) measurements because of their sensitivity, dynamic range, versatility, and processing tools [1]. Among the usual correction algorithms included in the instrument, filtering techniques in the time domain, also known as gating techniques, have proved to be a very valuable tool in order to remove isolation errors and to minimize the noise level present in the measurement. However, neither comparative studies among different techniques nor analytical formulations of individual ones can be found in the literature, to the knowledge of the authors.

This limits one to the internally supplied gating functions of the network analyzer, which has three important drawbacks: 1) because every frequency sweep must be gated, the measurement time increases substantially; 2) the gating parameters must be determined before carrying out the measurement; and 3) the gating of network analyzers presents a tradeoff between fast cutoff rates and low distortion effects in the frequency domain [2]. This can be critical in high-accuracy RCS or antenna measurements, where the desired response is often hidden by unwanted reflections, clutter, couplings, etc. The minimization of these distortion effects therefore requires the development of appropriate correction techniques.

This paper analyzes gating methods, introduces a new filtering technique and presents correction tools that reduce significantly the above mentioned distortion effects.

Manuscript received February 1, 1998; revised December 17, 1998. This work was supported in part by the Spanish Commission of Science and Technology under Grant TIC 96-0879.

The authors are with D3-Electromagnetics and Photonics Engineering Group, Department of Signal Theory and Communications, Universitat Politècnica de Catalunya, Barcelona 08034, Catalonia, Spain.

Publisher Item Identifier S 0018-9456(98)09928-8.

II. TRANSFORMATION TECHNIQUES

The filtering process in the time domain consists of three steps: 1) the measured frequency data is transformed to the time domain; 2) the time domain response is multiplied by a filter whose passband agrees with the target's response; and 3) the resulting signal is transformed back to the frequency domain. The notation that will be used for the parameters of each domain is the following:

A) *Initial Frequency Domain (Measured Data)*:

f_1, f_2, N_f = Start, stop frequencies, and number of samples;

δf = Frequency interval between samples;

ΔB = Frequency bandwidth ($f_2 - f_1$).

B) *Time Domain*:

t_1, t_2, N_t = Start, stop time and number of samples;

δt = Time interval between samples;

$T_{+\text{alias}} = 1/(\delta f)$ = Alias-free interval.

C) *Final Frequency Domain (Processed Data)*:

f'_1, f'_2, N'_f = Frequency start, stop, and number of samples;

$\delta f'$ = Frequency interval between samples;

$\Delta B'$ = Frequency bandwidth ($f'_2 - f'_1$).

The method most widely used to carry out these domain transformations is the chirp z-transform (CZT) [3], [4]. The transformation of measured data from the frequency domain to the time domain is obtained by means of the inverse chirp z-transform (ICZT) as follows [5]:

$$x(t_1 + n\delta t) = \frac{1}{N_f} \sum_{k=0}^{N_f-1} X(k) e^{j2\pi(f_1 + k\delta f)(t_1 + n\delta t)}, \quad n = 0, 1, \dots, N_t - 1. \quad (1)$$

Likewise, the transformation from the time domain back to the frequency domain by means of the CZT will be given by

$$Y(f_1 + m\delta f') = \sum_{n=0}^{N_t-1} x(n) e^{-j2\pi(f'_1 + m\delta f')(t_1 + n\delta t)}, \quad m = 0, 1, \dots, N'_f - 1. \quad (2)$$

Both transforms can be efficiently applied by means of fast Fourier transforms (FFT's) [3]. When working with the CZT, however, we must take into account that $CZT[ICZT[X(k)]]$ will not agree with $X(k)$ unless $t_2 - t_1 = T_{\text{alias}}$. This means that if we use the ICZT to transform from the frequency domain to the time domain and we transform back to the frequency domain by means of the CZT, the measured and processed frequency data may not agree. To analyze this effect, let us assume that the frequency interval between samples is maintained, that is, $\delta f = \delta f'$. Substituting (1) into (2) yields

$$Y(m) \equiv Y(f'_1 + m\delta f) = \frac{1}{N_f} \sum_{n=0}^{n_t-1} \sum_{k=0}^{N_f-1} X(k) e^{j2\pi(f_1+k\delta f)(t_1+n\delta t)} e^{-j2\pi(f'_1+k\delta f)(t_1+n\delta t)} \quad (3)$$

and operating we obtain

$$Y(m) = CZT\{ICZT[X(k)]\} = \frac{1}{N_f} e^{j\pi(t_1+t_2)(f_2-f'_1)} X(k) * J(k) \quad (4)$$

$$J(k) = e^{j\pi(t_1+t_2)\delta f k} \frac{\sin\left[\pi N_t \delta t \delta f \left(k + \frac{f_1 - f'_1}{\delta f}\right)\right]}{\sin\left[\pi \delta t \delta f \left(k + \frac{f_1 - f'_1}{\delta f}\right)\right]} \quad (5)$$

In conclusion, instead of obtaining the original measured data $X(k)$, $Y(m)$ is affected by the convolution with function $J(k)$ which has the form of a digital sinc. This convolution has two direct effects. On the one hand, the main lobe of the sinc degrades the frequency band edges and on the other hand, the secondary lobes of the digital sinc generate a ripple on the original data $X(k)$. The -3 -dB width of the main lobe is

$$\Delta B_{-3 \text{ dB}}^J = \delta f \frac{1}{N_t \delta t \delta f} = \frac{N_t - 1}{N_t (t_2 - t_1)} \approx \frac{1}{t_2 - t_1} \quad (6)$$

Thus, the smaller the interval in the time domain, the wider the sinc's main lobe and, therefore, the higher the distortion. When filtering techniques are to be applied in the time domain it is therefore important to extend the time interval from zero to T_{alias} so that the distortions generated by the transformation process are minimized. Fig. 1 shows the effect of $J(k)$ over a constant frequency response of 0-dB amplitude, whose time domain response corresponds to a delta peak located at $t = 52.6$ ns. If instead of transforming from the frequency domain to the time domain with $t_1 = 0$ and $t_2 = T_{\text{alias}}$, we choose $t_1 = 51.6$ and $t_2 = 53.6$, and we now apply the CZT to transform back to the frequency domain, we obtain a distorted version of the original frequency response equal to its convolution with $J(k)$.

III. GATING

In the gating process commonly used by commercial network analyzers [6], [7] the filter (or *gate*) is generated by convolving a time-domain rectangle function with an impulse response windowed with a Kaiser–Bessel window [2], [8], [9]. The filter used in the examples that follow is a finite impulse

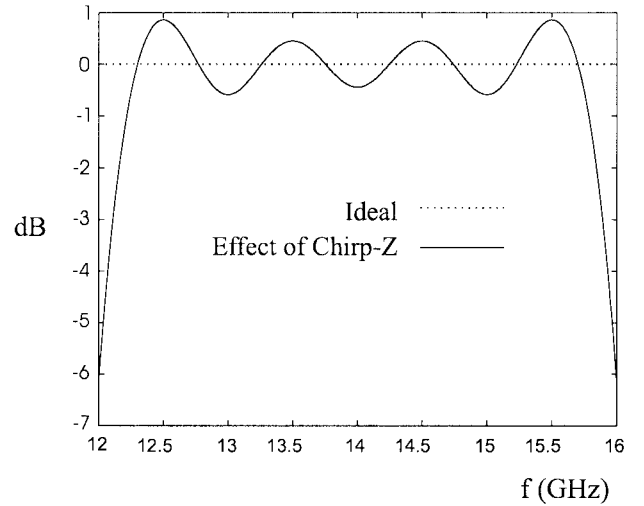

Fig. 1. Distortion generated in the frequency domain by applying ICZT and CZT to transform from the frequency domain to the time domain and back.

response (FIR) filter generated with this same technique and whose parameters are nominally: sidelobe ratio = 45 dB, pass-band ripple = 0.04 dB and cutoff (ns) = $1.4/\Delta B$ [6], [7]. Other windows provide different tradeoffs: the ones that generate less distortion in the frequency domain, present cutoff rates too slow to discriminate between very closed responses. The transformed response of the filter is a sinc-like function $H(k)$ whose main lobe is approximately the inverse of the bandpass width, that is

$$\Delta B_{-3 \text{ dB}}^H \approx \frac{1}{\text{gate}_{\text{stop}} - \text{gate}_{\text{start}}} \quad (7)$$

The filtering process can be therefore regarded as the convolution between the original data and this sinc-like function plus a new convolution by the digital sinc in (5) due to the CZ

$$Y(k) = [X(k) * H(k)] * J(k) \quad (8)$$

Even if the adopted interval in the time domain is $[0, T_{\text{alias}}]$ which transforms $J(k)$ into a delta peak and thus removes its effects, the filter response $H(k)$ will distort the signal level at the frequency band edges and will generate a ripple at central frequencies (Fig. 2).

IV. CZF

In (8) we are applying twice the convolution between $X(k)$ and a sinc-like function: first with $H(k)$ and afterwards with $J(k)$. In fact, the parameters of the inverse and direct CZ transforms can be modified ($J \rightarrow J'$) in order to achieve the same result without generating a gate filter $H(k)$

$$Y(k) = X(k) * J'(k) \quad (9)$$

This method, which we will call CZF, consists of two steps. First, the measured frequency response is transformed to the time domain by means of the ICZT. The interval where the time domain response is calculated, however, is not $[0, T_{\text{alias}}]$ but $[\text{gate}_{\text{start}}, \text{gate}_{\text{stop}}]$, that is, the transformation is carried out so that $t_1 = \text{gate}_{\text{start}}$ and $t_2 = \text{gate}_{\text{stop}}$. Finally, the CZT is applied over this time interval. Nevertheless, as in the case of

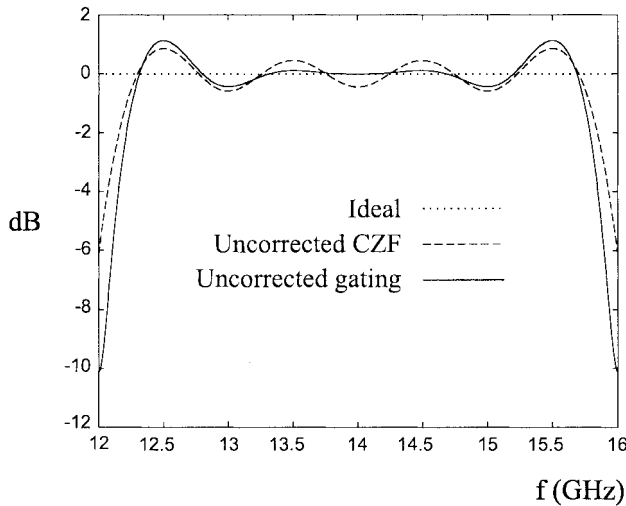

Fig. 2. Distortion generated in the frequency domain by CZ and gating when no correction techniques are used.

gating, the development of appropriate correction techniques is required in order to remove the distortions generated in the frequency domain (Fig. 2).

V. CORRECTION TECHNIQUES: EXTRAPOLATION AND EQUALIZATION

The distortion in the frequency band edges produced by the main lobe of the sinc-like functions $H(k)$ in the case of gating and $J'(k)$ in the case of the CZF can be reduced by extrapolating the measured data. In this way, the distortion will mainly affect the extrapolated samples, which will be afterwards discarded. In the extrapolation process the real and imaginary parts of the measured frequency data $X(k)$ are extrapolated below f_1 and beyond f_2 by a frequency extrapolation length Δf_e whose optimal value has been determined by applying different extrapolation lengths over experimental and simulated data. The best results have been obtained with $\Delta f_e = 2.5\Delta B_{-3\text{dB}}$. Higher values obtain hardly any improvement and only increase computing time [10].

The ripple still present in the data after extrapolating and filtering may be reduced with equalization [11]. The equalization process requires a *calibration* signal with well-known responses in the frequency and time domains. This signal is first extrapolated and filtered and the result $E'(k)$ is then compared with the expected result $E^*(k)$. From this comparison, a correction factor is derived. The notation used in Fig. 3 to illustrate this process is the following.

$X(k), E(k)$	Measured signal and calibration signal in the frequency domain.
$E^*(k)$	Calibration signal after filtering if no distortion were present.
$X_e(l), E_e(l)$	Extrapolated, measured, and calibration signals.
$Y'(k), E'(k)$	Measured and calibration signals after filtering.
$\varepsilon(k) = E^*(k)/E'(k)$	Equalization factor.
$Y(k) = Y'(k)\varepsilon(k)$	Filtered signal with extrapolation and equalization.

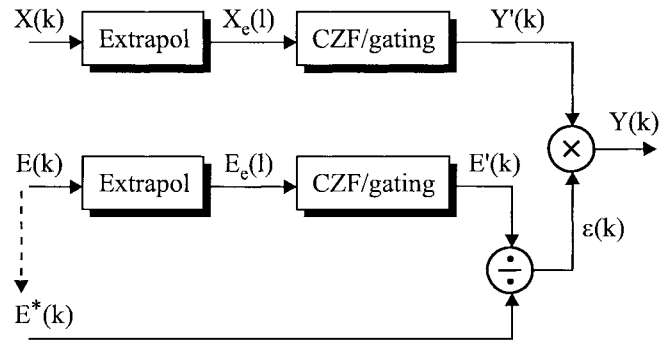

Fig. 3. Filtering process using extrapolation and equalization to minimize distortions in the frequency domain.

The calibration signal should meet two requirements: first, its time-domain response should lay within a very narrow interval so that narrow filters can be applied over it and second, its frequency-domain response should not present zeros or low values. Otherwise, $\varepsilon(k)$ would be affected by numerical errors caused by division by zero. A function that fully satisfies these requirements is a delta peak in the time domain. Furthermore, it can be easily generated as a complex exponential whose exponent allows to select the time position of the delta peak.

Similar techniques to those above presented are used by commercial network analyzers, although they are not described in the technical documentation supplied by the manufacturers.

VI. RESULTS

The performance between the gating and CZF with extrapolation and equalization will be now compared with the results obtained by an HP-8720C network analyzer when using the same gate shape specified previously. Two cases have been analyzed [11]. A simulation of a set of delta peaks in the time domain, and an experimental RCS measurement of a metallic trihedral.

1) *Set of Delta Peaks in the Time Domain:* In this example an interfering signal appears very close (2 ns) to the target's response [Fig. 4(a)]. To make matters worse, the amplitude of the interfering peak has been chosen to be higher than the target's amplitude and a third peak that simulates the coupling between antennas has been introduced. The filter span is 1 ns and it is centered at 100 ns. The results obtained with the proposed gating are clearly the best in terms of minimum quadratic error [Fig. 4(b)]. With this method, the error lies approximately within the interval $[-0.05, 0]$ dB across the whole frequency range and the normalized square error is 0.4%. CZF also presents a very good performance with an error around $[-0.05, 0.05]$ dB and a square error of 0.9%. As for the gating of the network analyzer, although the results from 13 to 15 GHz are excellent, its behavior shows a strong degradation near 12 and 16 GHz, with an error that exceeds 0.3 dB. With this method, the square error is equal to 1.5%.

2) *Trihedral:* In this case an outdoor measurement has been undertaken over a well-known external calibrator, a metallic trihedral of 22-cm edge. This target generates two very close peaks in the time domain, from which only the first one has to be preserved. The second peak corresponds to the surface

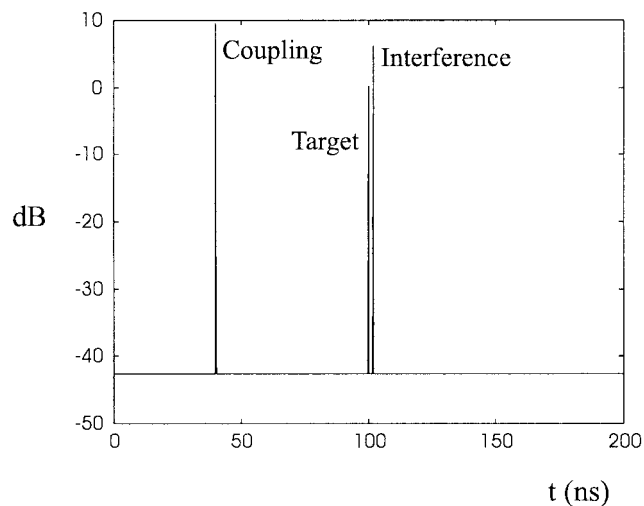

(a)

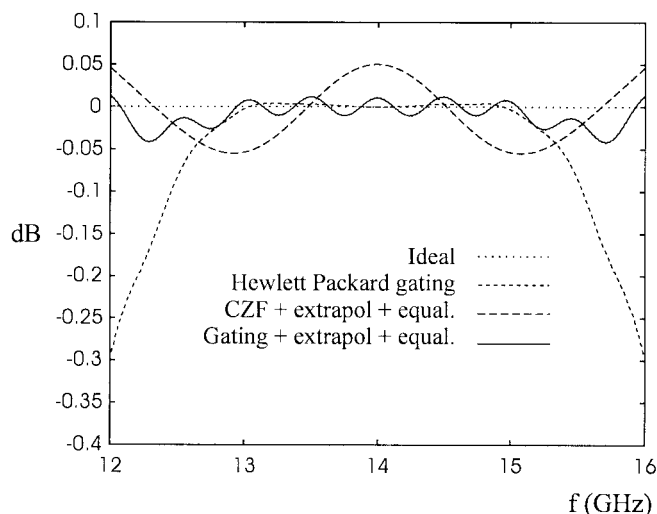

(b)

Fig. 4. (a) Simulated time domain response of a RCS measurement consisting of coupling between antennas, target and an interference signal. (b) Frequency response of the RCS measurement corresponding to Fig. 3(a) after filtering out the unwanted signals by means of: 1) ideal filtering; 2) HP gating; 3) CZF + correction techniques; and 4) proposed gating + correction techniques.

wave generated by the incident wave and is only 1 ns away from the target's peak [Fig. 5(a)]. The results obtained with the proposed gating and CZF methods are practically identical [Fig. 5(b)]. Assuming that the mechanical implementation of the trihedral is perfect, that is, its real response is equal to its theoretical response, the normalized square error introduced by these two methods is 7.7 and 8.4%, respectively. The network analyzer gating behaves well at central frequencies but gives poor results at the band edges, resulting in an overall error of 11.4%.

VII. CONCLUSIONS

The problem of domain transformations and filtering techniques in RCS measurements has been studied in this paper, and tools to develop them optimally have been given. Conventional gating techniques perform very well in many situations

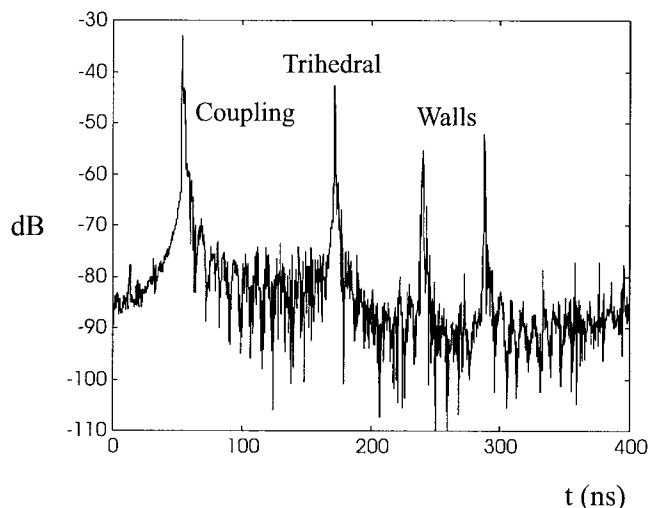

(a)

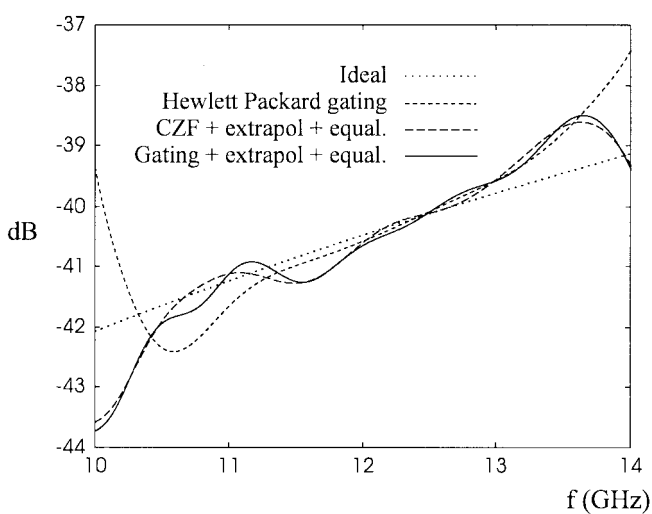

(b)

Fig. 5. (a) Measured time domain response of a trihedral. (b) Frequency response of the trihedral after the filtering process by means of: 1) ideal filtering; 2) HP gating; 3) CZF + correction techniques; and 4) proposed gating + correction techniques.

but are unable to achieve simultaneously fast cutoff rates and low distortion in the frequency domain. We have presented two correction techniques that, applied along with gating, obtain better performance than conventional techniques in the mean square error sense. Furthermore, a new filtering technique called CZF has been presented, which, when applied together with correction techniques, obtains very good results. The CZF does not require creation of a filter and therefore is faster than gating.

REFERENCES

- [1] F. T. Ulaby, M. W. Whitt, and K. Sarabandi, "AVNA-based polarimetric scatterometers," *IEEE Antennas Propagat. Mag.*, vol. 32, pp. 6–17, Oct. 1990.
- [2] D. Rytting, "Let time domain response provide additional insight into network behavior," in *Proc. RF & Microwave Measurement Symp. Exhibition*, Santa Rosa, CA, 1984, pp. 1–31.
- [3] L. R. Rabiner, R. W. Schafer, and C. M. Rader, "The chirp z -transform algorithm," *IEEE Trans. Audio Electroacoust.*, vol. AU-17, pp. 86–92, June 1969.

- [4] A. V. Oppenheim and R. W. Schaffer, *Discrete-Time Signal Processing*. Englewood Cliffs, NJ: Prentice-Hall, 1989.
- [5] P. Nardone, "Chirp Z techniques," European Microwave Signature Laboratory (EMSL), Advanced Techniques, Joint Research Center (JRC), Ispira, Italy, Internal Note, 1993.
- [6] *HP-8510B Network Analyzer, Operating and Programming Manual*, Hewlett Packard, Santa Rosa, CA, 1987.
- [7] *HP-8719C, HP-8720C, HP-8722A/C Network analyzer, Operating Manual*, Hewlett Packard, Santa Rosa, CA, 1992.
- [8] F. J. Harris, "High-resolution spectral analysis with arbitrary spectral centers and arbitrary spectral resolutions," *Comp. Electr. Eng.*, vol. 3, pp. 171–191, 1976.
- [9] F. J. Harris, "On the use of windows for harmonic analysis with the discrete fourier transform," *Proc. IEEE*, vol. 66, pp. 51–83, Jan. 1978.
- [10] L. F. Martínez, "Caracterización y Optimización de los Módulos de Procesamiento y de Radiofrecuencia de un Dispersómetro Polarimétrico," final year project, Universitat Politecnica de Catalunya, Catalunya, Spain, 1996.
- [11] R. De Porrata-Doria, "Wide band polarimetric scatterometers based on vector network analyzers for Remote Sensing Applications," Ph.D. dissertation, Universitat Politecnica de Catalunya, Catalunya, Spain, 1997.

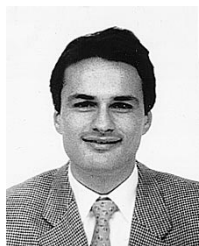

Ramir De Porrata-Doria i Yagüe received the Ingeniero and Doctor Ingeniero degrees in telecommunication engineering from the Universitat Politecnica de Catalunya, Barcelona, Spain, in 1992 and 1997, respectively.

His research interests include scatterometry applications and systems, synthetic aperture radars, and pattern recognition.



Antoni Broquetas Ibars (S'84–M'90) was born in Barcelona, Spain, in 1959. He received the Ingeniero and the Doctor Ingeniero degrees in telecommunication engineering from the Universitat Politecnica de Catalunya, Barcelona, Spain, in 1985 and 1989, respectively.

In 1986, he was a Research Assistant in the Portsmouth Polytechnic, Portsmouth, U.K., where he was involved in propagation studies. In 1987, he joined the Department of Signal Theory and Communications of the School of Telecommunication Engineering, Universitat Politecnica de Catalunya. He is now an Associate Professor at the same institution, where he is involved in research on radar imaging and remote sensing.



Luis Fernando Martínez received the Ingeniero degree in telecommunication engineering from the Universitat Politecnica de Catalunya, Barcelona, Spain, where he carried out his final year project in the remote sensing area focusing on signal processing techniques and tools.

His research interests include remote sensing applications, network analyzers, and time-domain filtering techniques.