



Escola Superior d'Enginyeries Industrials,  
Aeroespacial i Audiovisual de Terrassa

UNIVERSITAT POLITÈCNICA DE CATALUNYA

Trabajo final de grado

Grado en Ingeniería industrial electrónica y automática

# **ESTUDIO DE LAS ETAPAS DE AUTOMATIZACIÓN DE UN PROCESO INDUSTRIAL: COMUNICACIONES Y OPERACIÓN**

## **ANEXO III: PROGRAMAS CONTROL LINEAS**

**Autor:** Nil Munuera Cano  
**Director:** Miguel Delgado Prieto  
**Co-Director:** Ángel Fernández Sobrino  
**Convocatoria:** Enero 2020



ÍNDICE:

LINEA PROFIBUS:..... 2

    Reset:..... 2

    Cinta\_central:..... 5

    Cinta\_derecha1:..... 7

    Cinta\_derecha2:..... 8

    Salidas\_central: ..... 9

    Salidas\_derecha1: ..... 10

    Salidas\_derecha2: ..... 11

    Tracking: ..... 12

    Ordering: ..... 17

LINEA CAN: ..... 19

    Reset:..... 19

    Cinta\_central:..... 22

    Cinta\_izquierda1: ..... 25

    Cinta\_izquierda2: ..... 28

    Salidas\_central: ..... 30

    Salidas\_izquierda1:..... 31

    Salidas\_izquierda2:..... 33

    Tracking: ..... 34

PULMÓN:..... 38

    Reset:..... 38

    Alarmas:..... 38

    Estados: ..... 41

    Reposo:..... 42

    Carga\_palet: ..... 43

    Descarga\_palet:..... 44

    Activacion\_salidas:..... 45

## LINEA PROFIBUS:

### Reset:

```
IF %S13 THEN
    PIEZA:=1;
    PIEZAS_TOTALES:=3;

    ArrayPT08_INICIO[0]:=1;
    ArrayPT08_INICIO[1]:=3;
    ArrayPT08_INICIO[2]:=2;

    Array_vacia[0]:=0;
    Array_vacia[1]:=0;
    Array_vacia[2]:=0;
    Array_vacia[3]:=0;
    Array_vacia[4]:=0;
    Array_vacia[5]:=0;
    Array_vacia[6]:=0;
    Array_vacia[7]:=0;
    Array_vacia[8]:=0;
    Array_vacia[9]:=0;

    DIRI10_REST := TRUE;
    DIRI11_REST := TRUE;
    DIRI12_REST := TRUE;
    DIRI13_REST := TRUE;
    DIRI14_REST := TRUE;
    DIRI15_REST := TRUE;
    DIRI16_REST := TRUE;
    DIRI17_REST := TRUE;
    DIRI18_REST := TRUE;
    DIRI19_REST := TRUE;

    DIRI10_READY := FALSE;
    DIRI11_READY := FALSE;
    DIRI12_READY := FALSE;
    DIRI13_READY := FALSE;
    DIRI14_READY := FALSE;
    DIRI15_READY := FALSE;
    DIRI16_READY := FALSE;
    DIRI17_READY := FALSE;
    DIRI18_READY := FALSE;
    DIRI19_READY := FALSE;
```

```
DIRI10_MOVE := FALSE;
DIRI11_MOVE := FALSE;
DIRI12_MOVE := FALSE;
DIRI13_MOVE := FALSE;
DIRI14_MOVE := FALSE;
DIRI15_MOVE := FALSE;
DIRI16_MOVE := FALSE;
DIRI17_MOVE := FALSE;
DIRI18_MOVE := FALSE;
DIRI19_MOVE := FALSE;

PTI08_REST := TRUE;
PTI09_REST := TRUE;
PTI10_REST := TRUE;
PTI11_REST := TRUE;
PTI12_REST := TRUE;
PTI13_REST := TRUE;
PTI14_REST := TRUE;

PTI08_READY := FALSE;
PTI09_READY := FALSE;
PTI10_READY := FALSE;
PTI11_READY := FALSE;
PTI12_READY := FALSE;
PTI13_READY := FALSE;
PTI14_READY := FALSE;

PTI08_MOVE := FALSE;
PTI09_MOVE := FALSE;
PTI09_MOVE_right := FALSE;
PTI10_MOVE := FALSE;
PTI10_MOVE_right := FALSE;
PTI11_MOVE := FALSE;
PTI12_MOVE := FALSE;
PTI13_MOVE := FALSE;
PTI14_MOVE := FALSE;

%M81:=FALSE;
%M82:=FALSE;
%M83:=FALSE;
%M84:=FALSE;
%M85:=FALSE;
%M86:=FALSE;
%M87:=FALSE;
%M88:=FALSE;
%M89:=FALSE;
%M90:=FALSE;
%M91:=FALSE;
%M92:=FALSE;
%M93:=FALSE;
%M94:=FALSE;
%M95:=FALSE;
%M96:=FALSE;
```

```

C0_PTI08:=0;
C1_DIRI10:=0;
C2_PTI09:=0;
C3_DIRI11:=0;
C4_PTI10:=0;
C5_DIRI13:=0;
C6_DIRI14:=0;
C7_DIRI17:=0;
C8_DIRI15:=0;
C9_PTI12:=0;
C10_DIRI19:=0;
C11_PT12_salida:=0;
C12_PTI14:=0;
C13_PT14_salida:=0;
Import:=TRUE;

```

```
END_IF;
```

```
IF (contador_pulmon=PIEZAS_TOTALES) THEN
```

```

  ArrayPT14_PT15:=Array_vacia;
  ArrayPT08_PT09:=Array_vacia;
  ArrayPT09_PT10:=Array_vacia;
  ArrayPT09_PT12:=Array_vacia;
  ArrayPT10_PT12:=Array_vacia;
  ArrayPT10_PT14:=Array_vacia;
  ArrayPT12_PT14:=Array_vacia;
  C1_DIRI10:=0;
  C2_PTI09:=0;
  C3_DIRI11:=0;
  C4_PTI10:=0;
  C5_DIRI13:=0;
  C6_DIRI14:=0;
  C7_DIRI17:=0;
  C8_DIRI15:=0;
  C9_PTI12:=0;
  C10_DIRI19:=0;
  C11_PT12_salida:=0;
  C12_PTI14:=0;
  C13_PT14_salida:=0;

```

```
END_IF;
```

```
IF (PIEZA=PIEZAS_TOTALES) THEN
```

```
  Import:=FALSE;
```

```
END_IF;
```

### Cinta\_central:

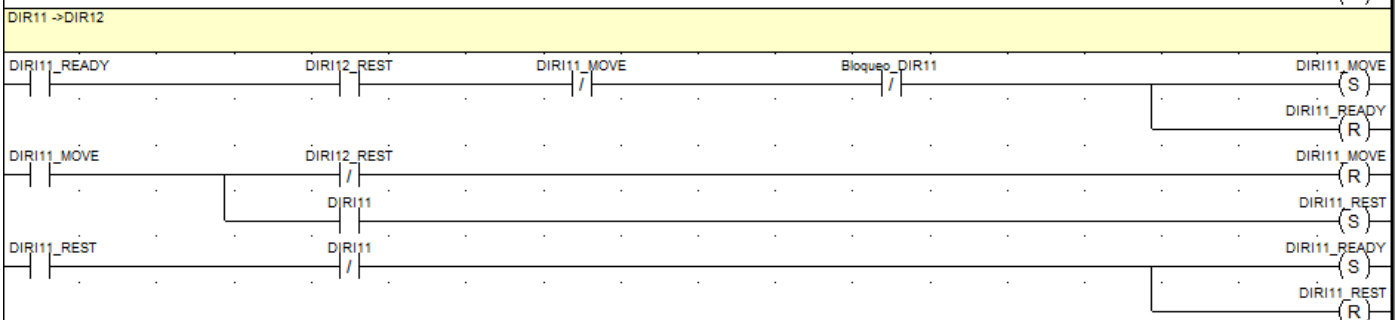
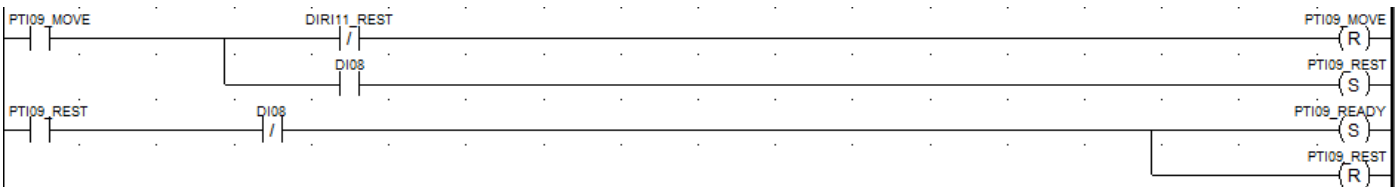
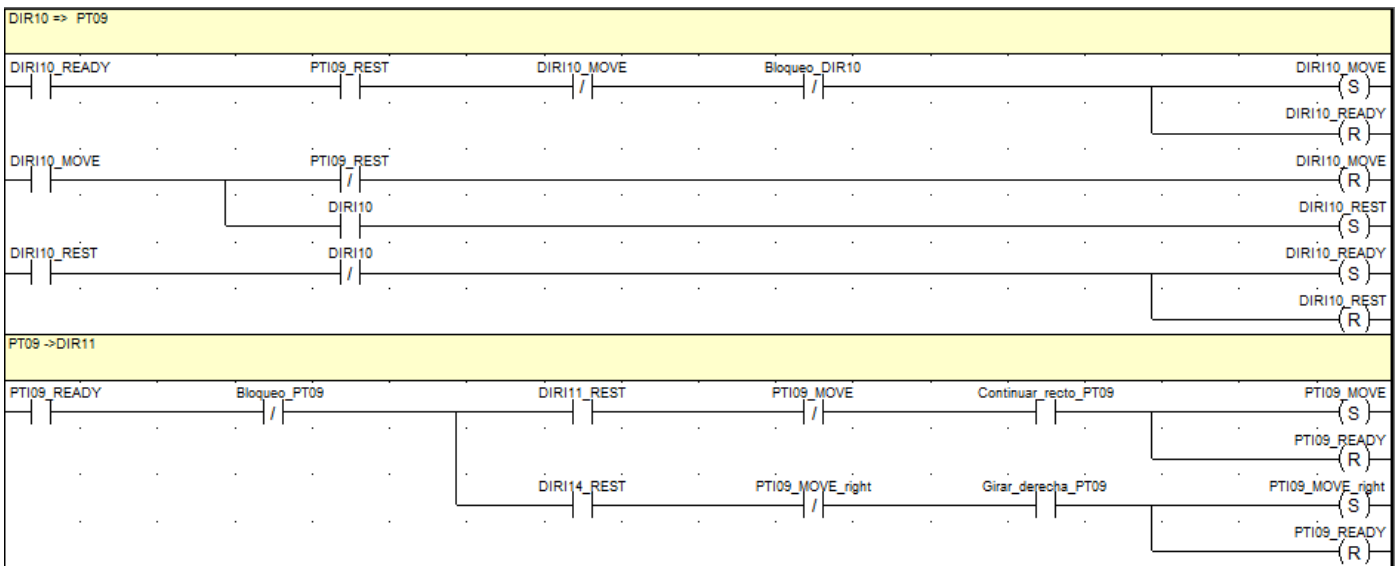
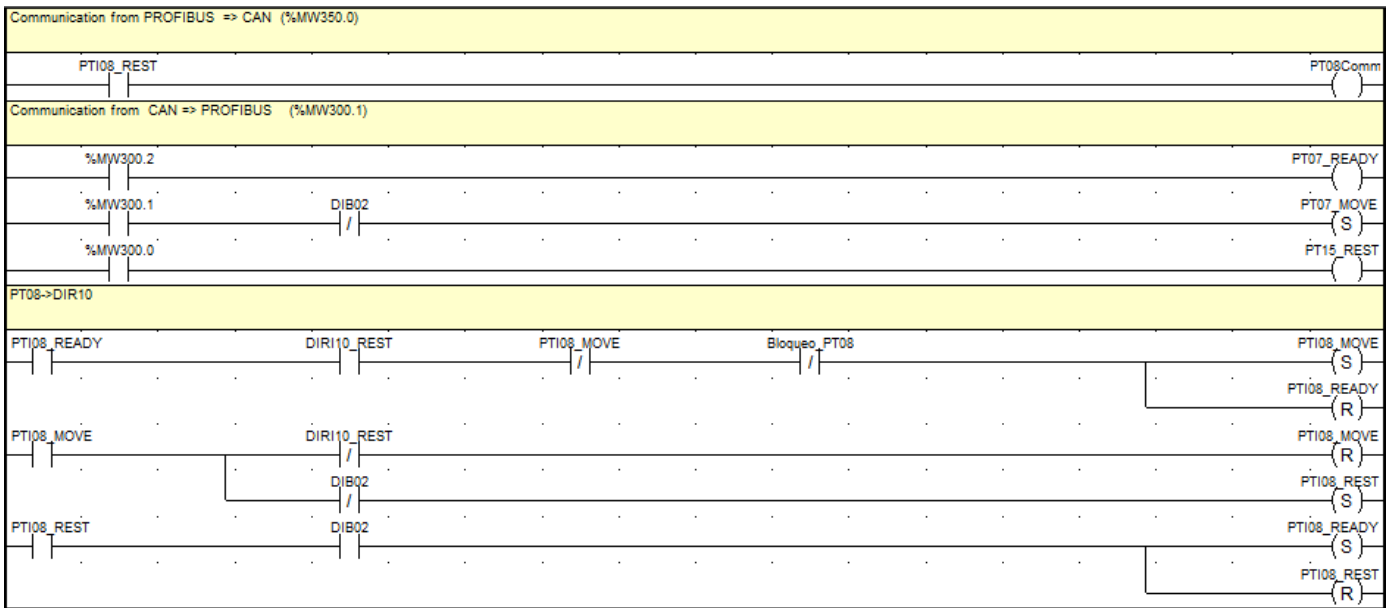

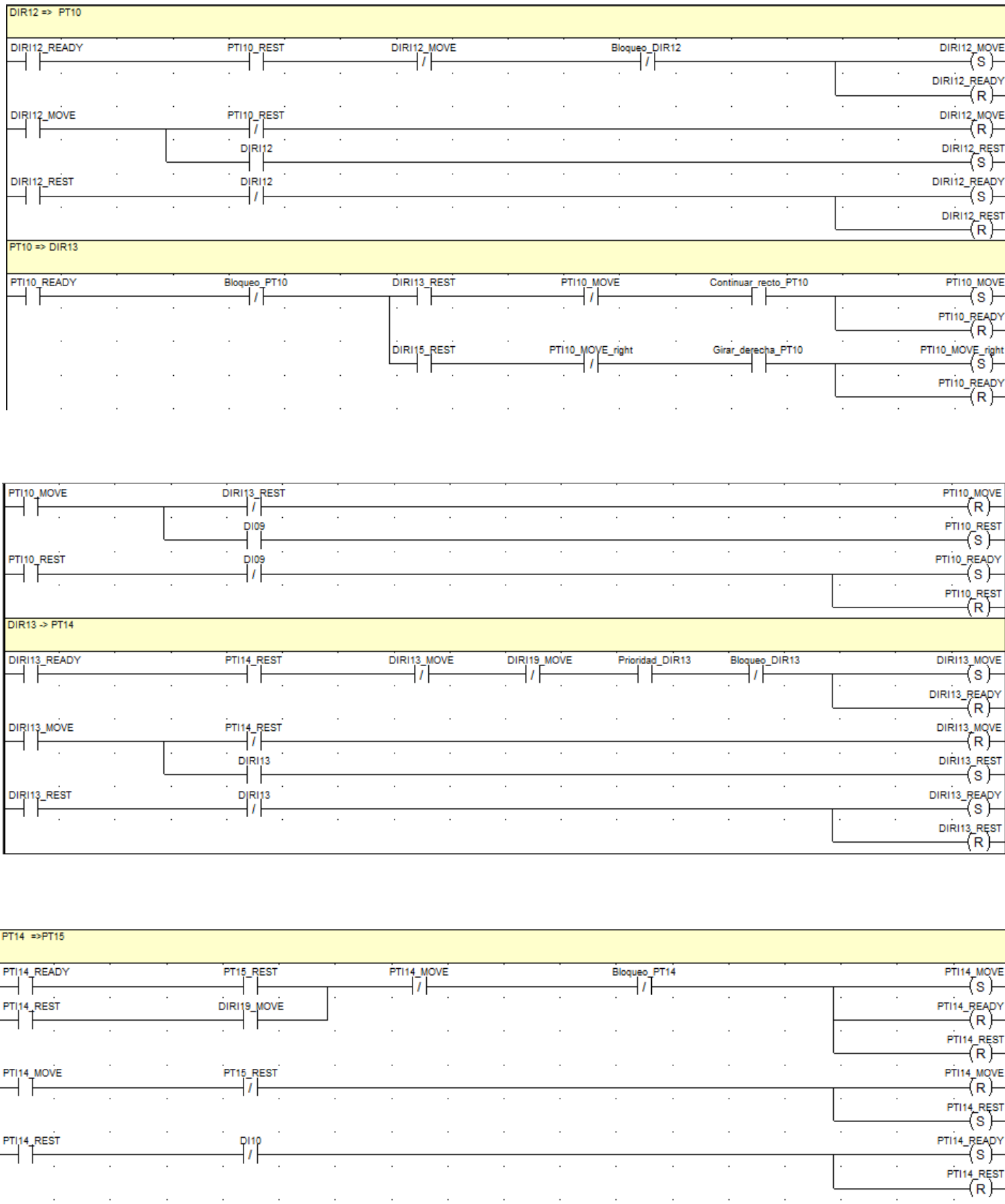





### Cinta\_derecha1:

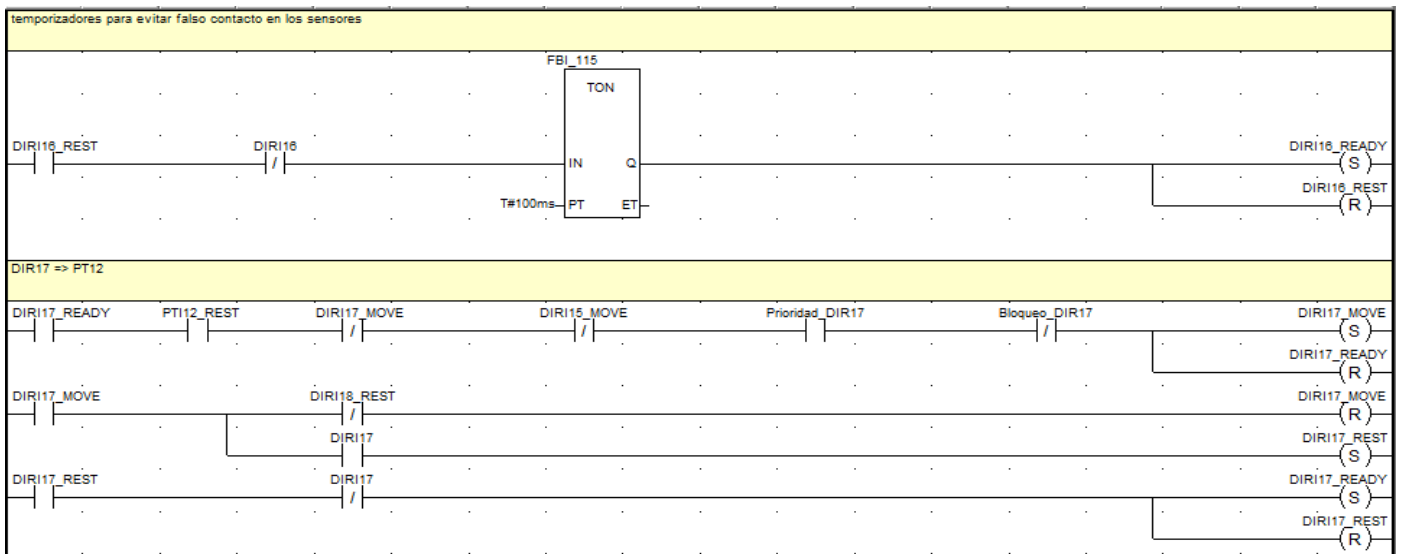
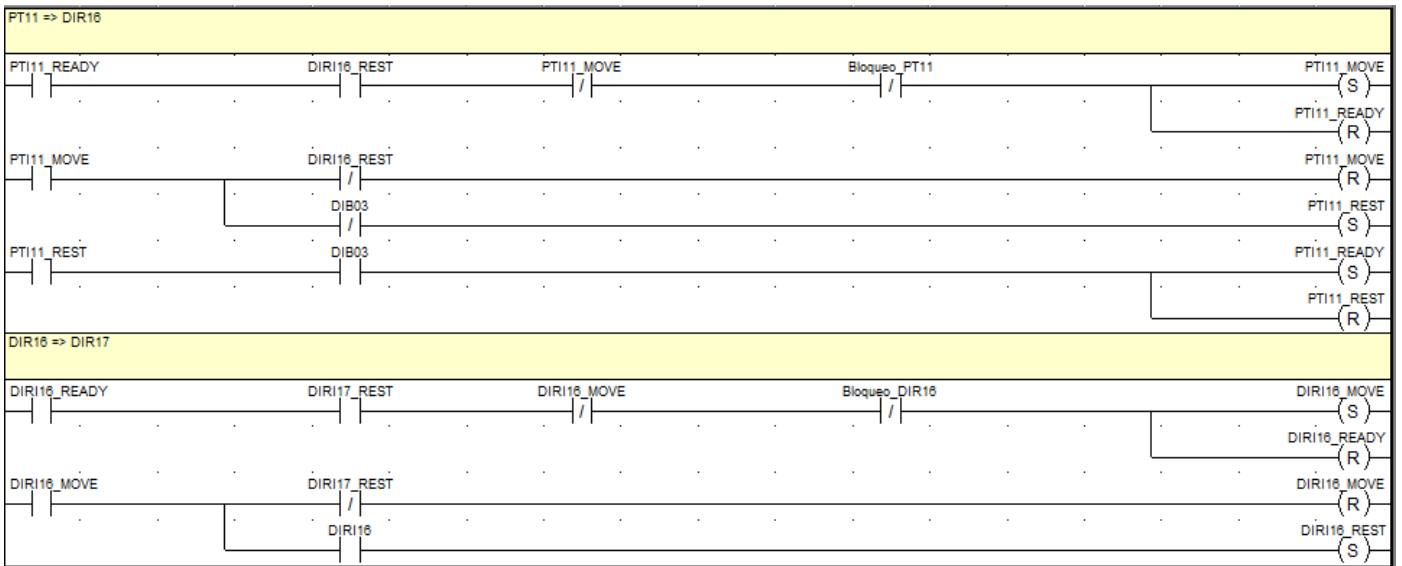
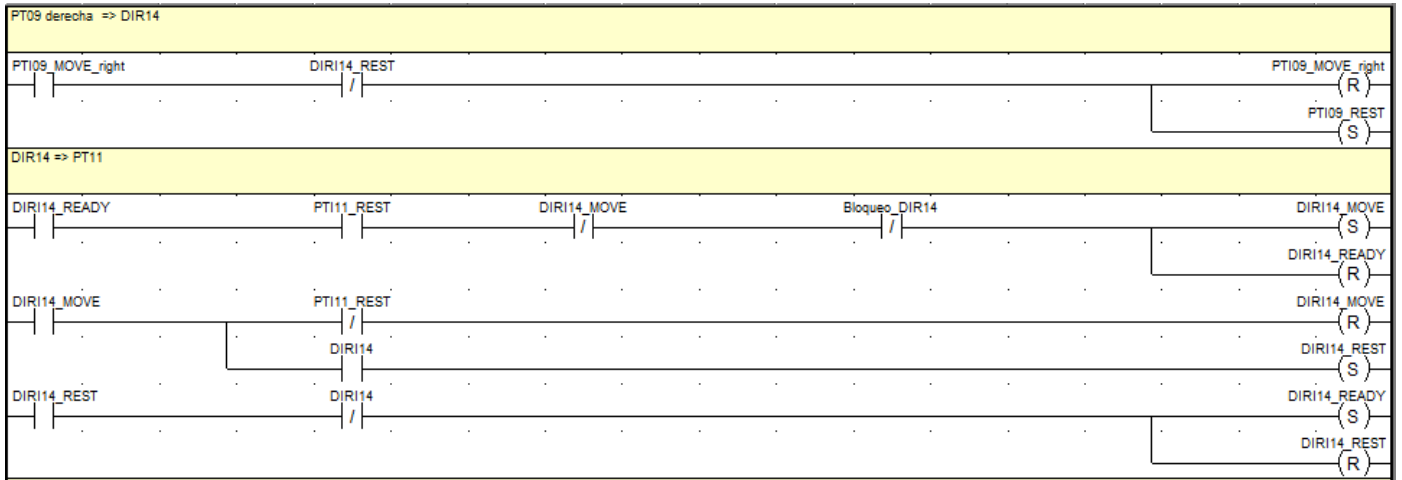



**Cinta\_derecha2:**

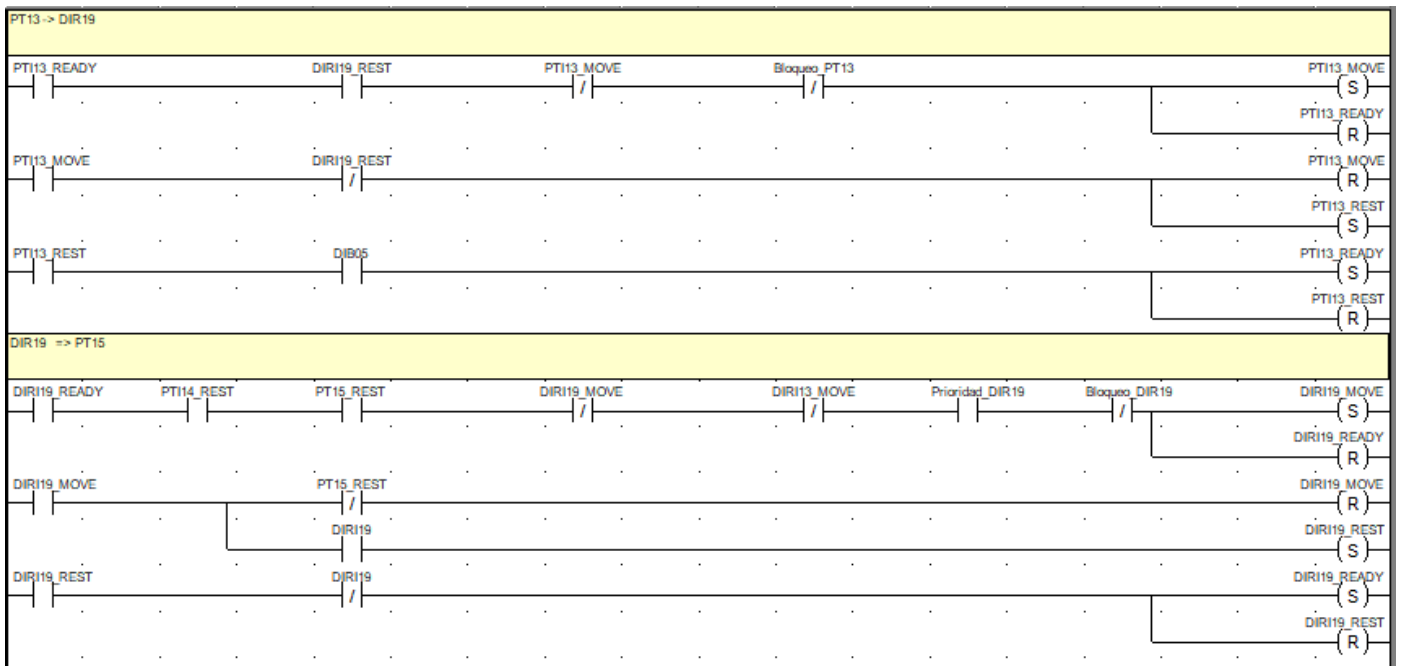
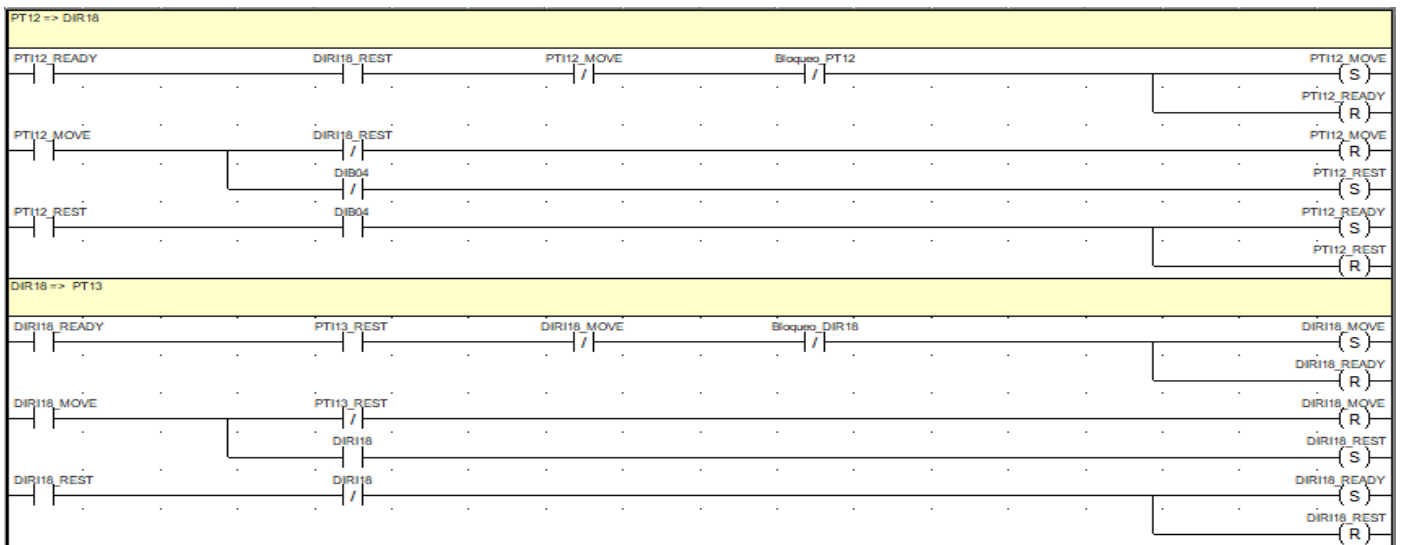
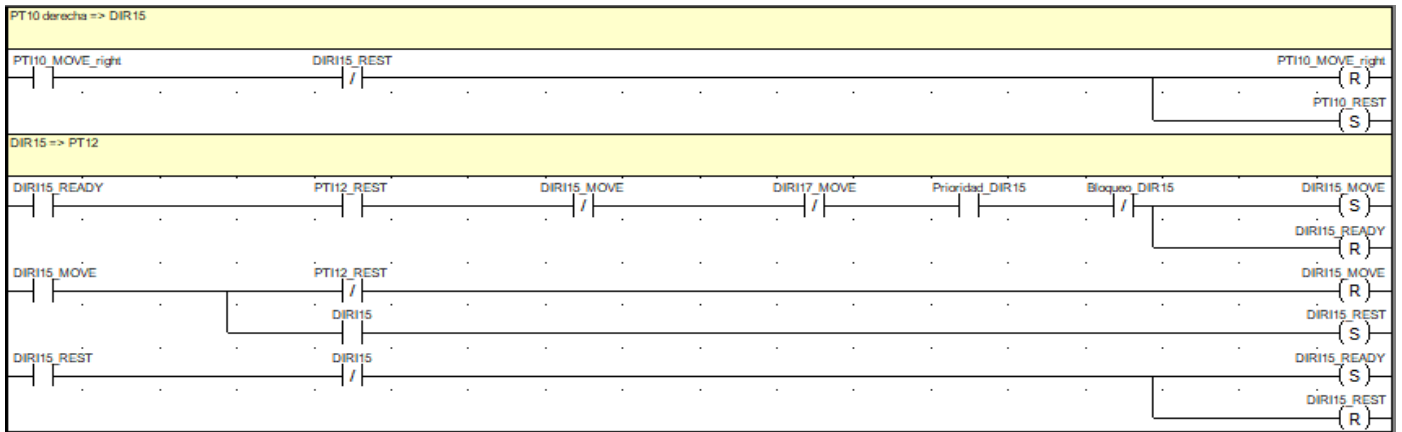

### Salidas\_central:

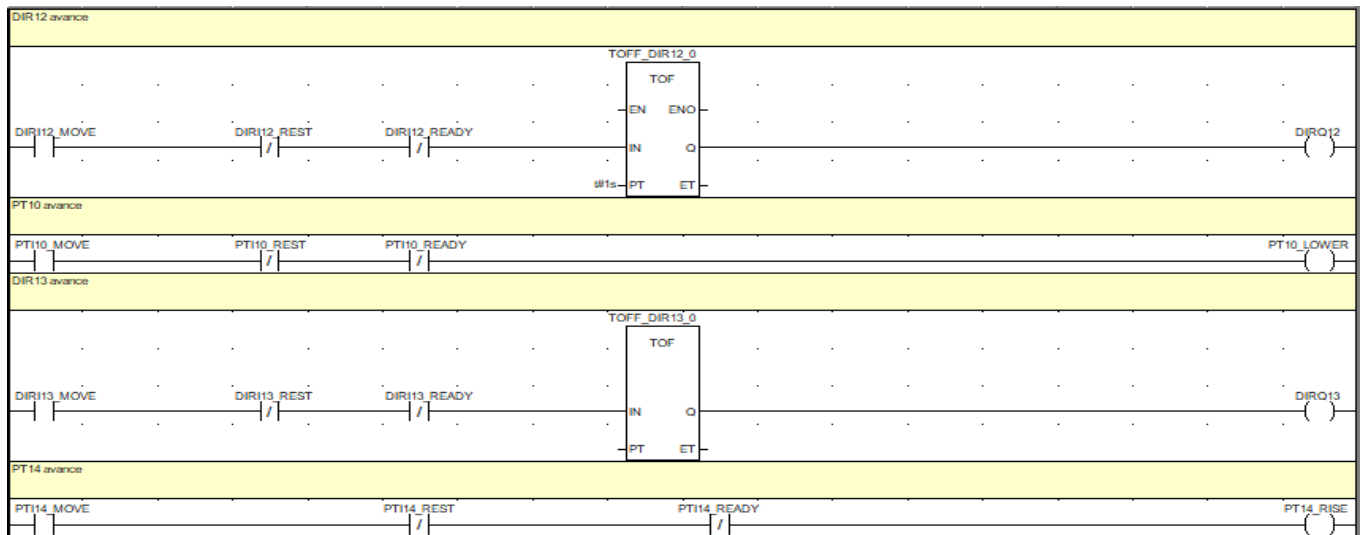
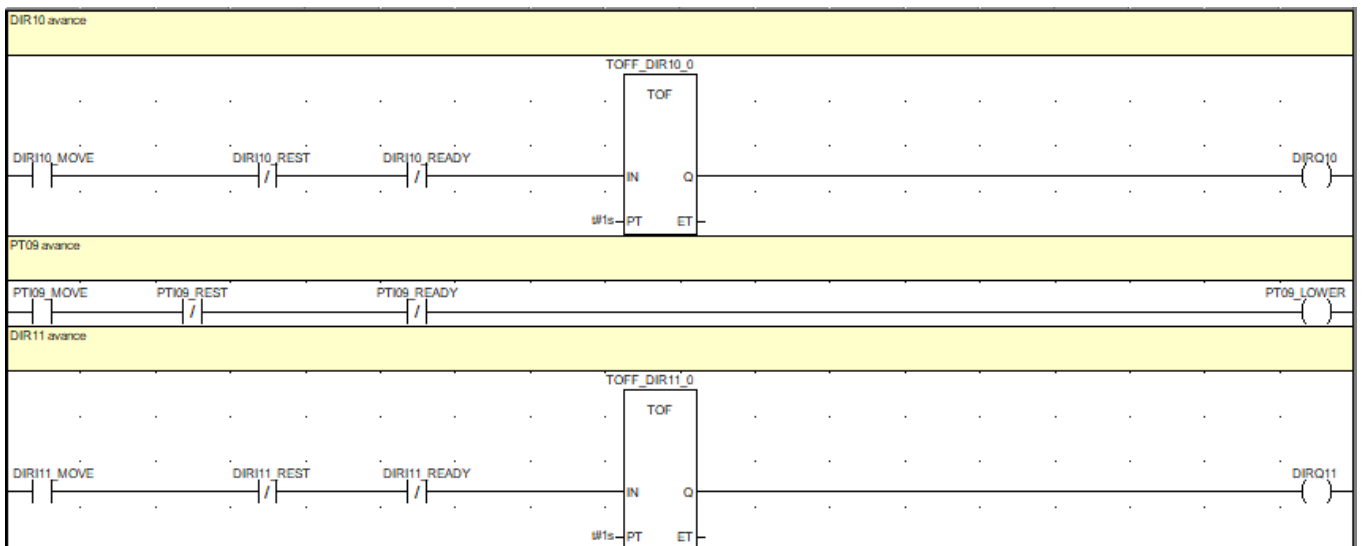
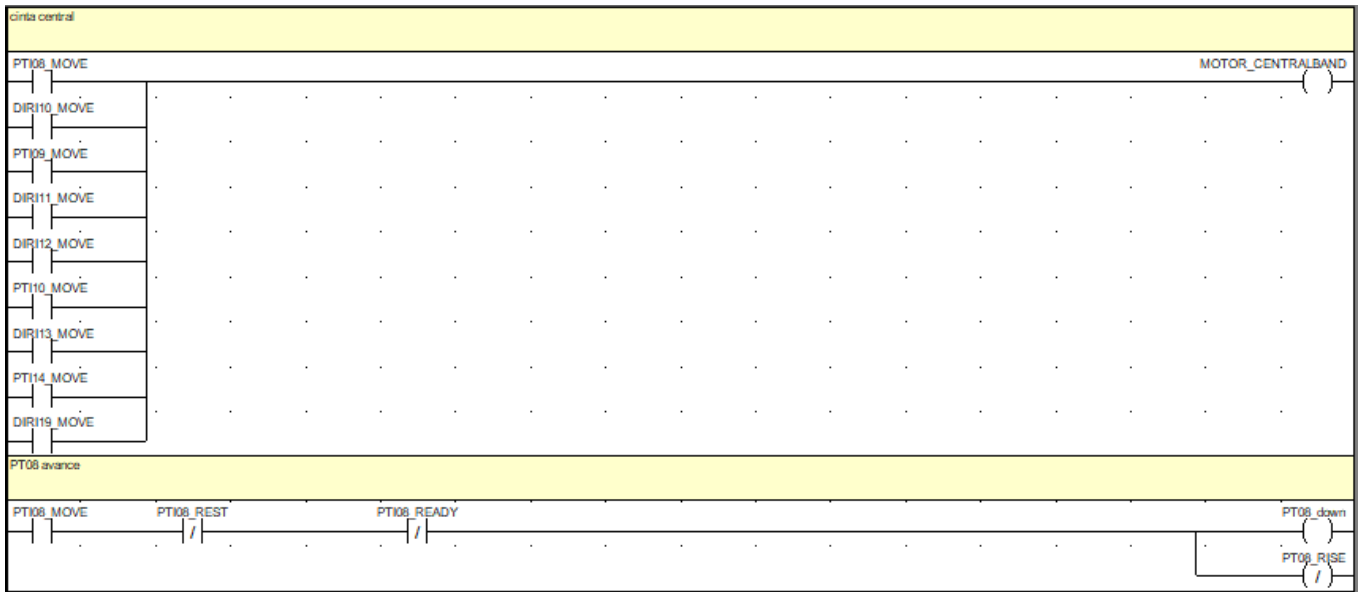

### Salidas\_derecha1:

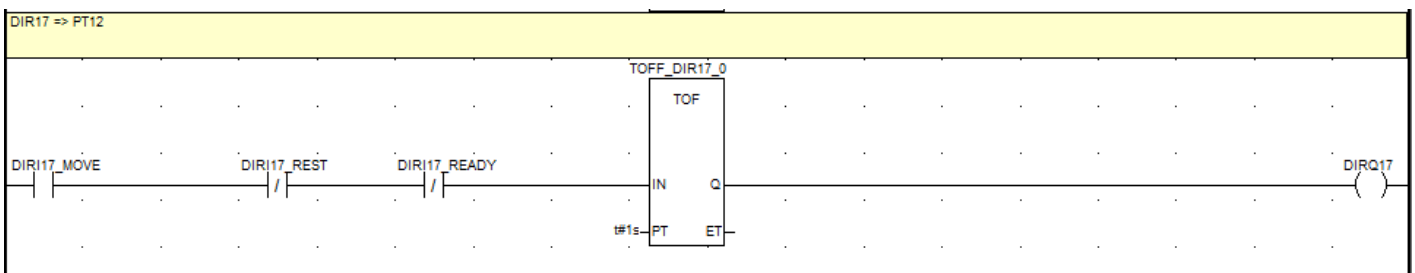
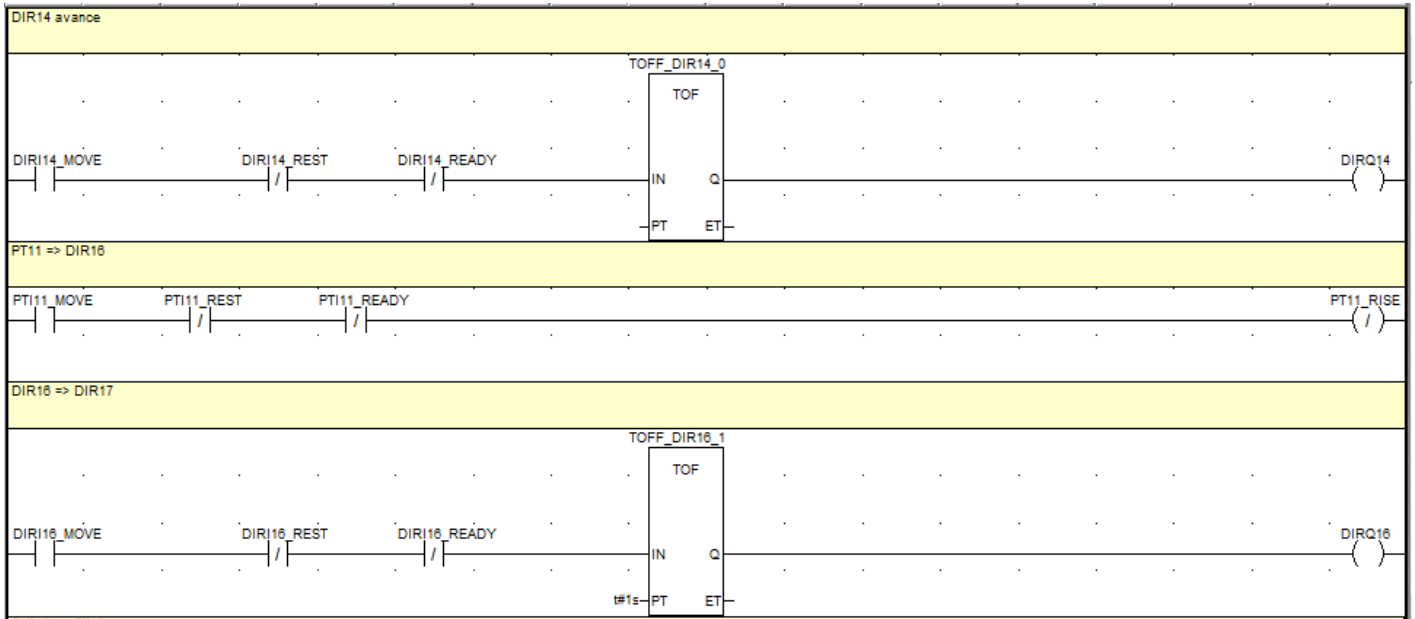
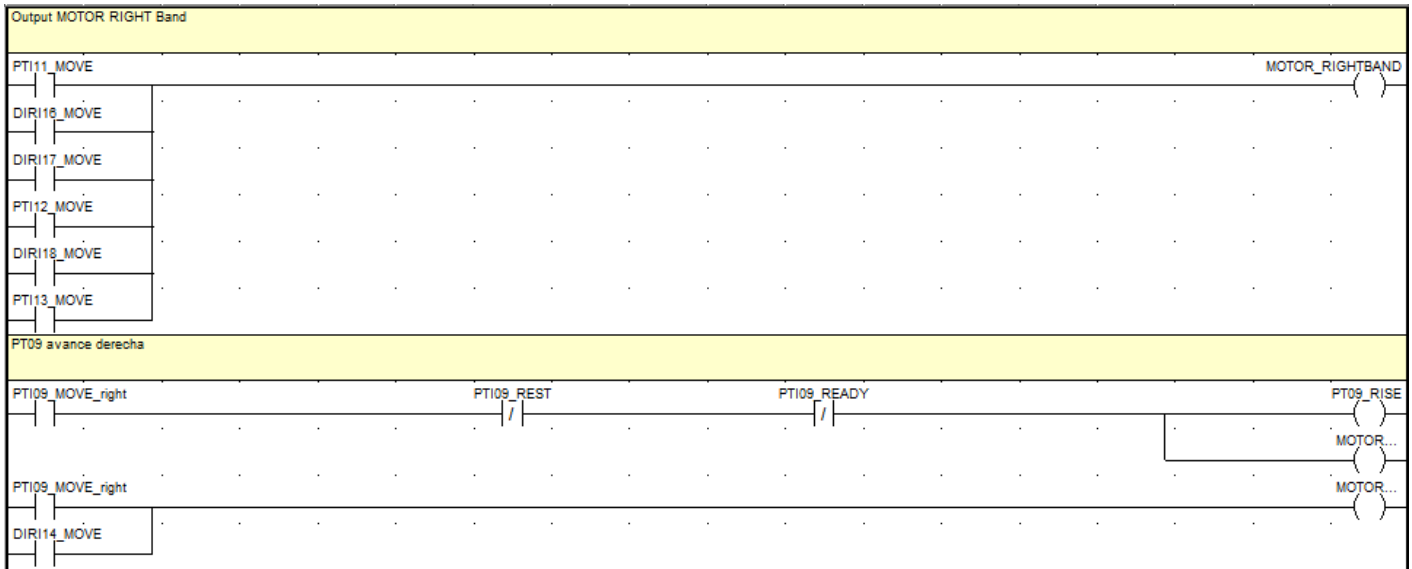

### Salidas\_derecha2:

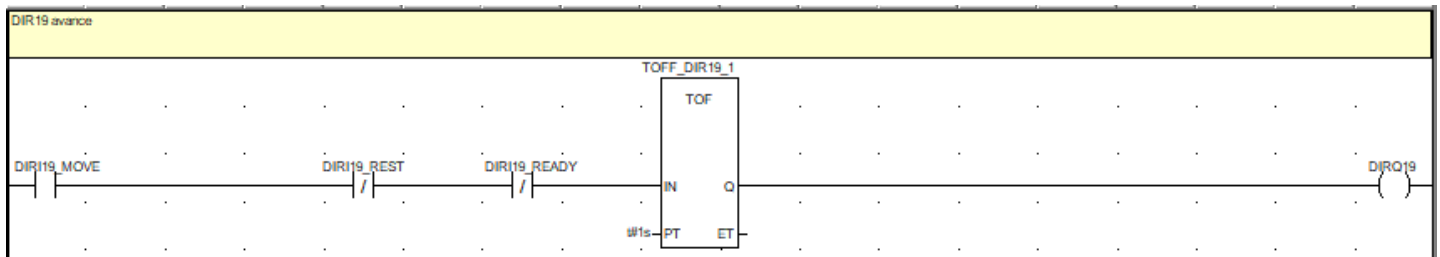
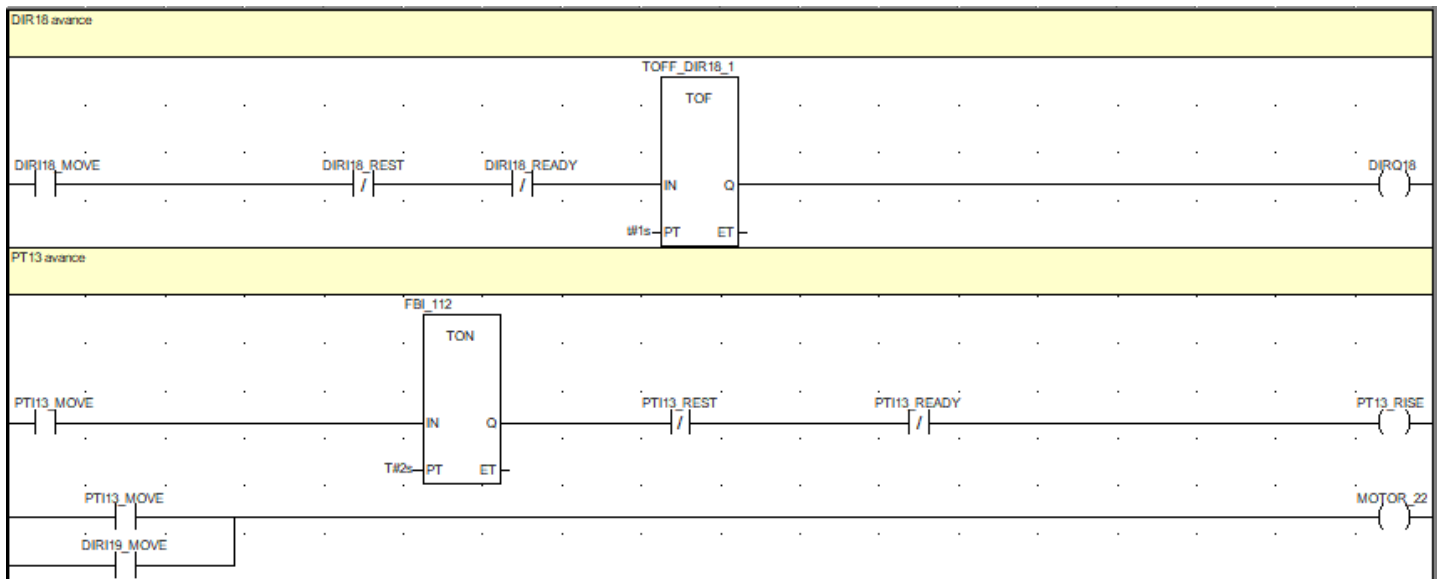
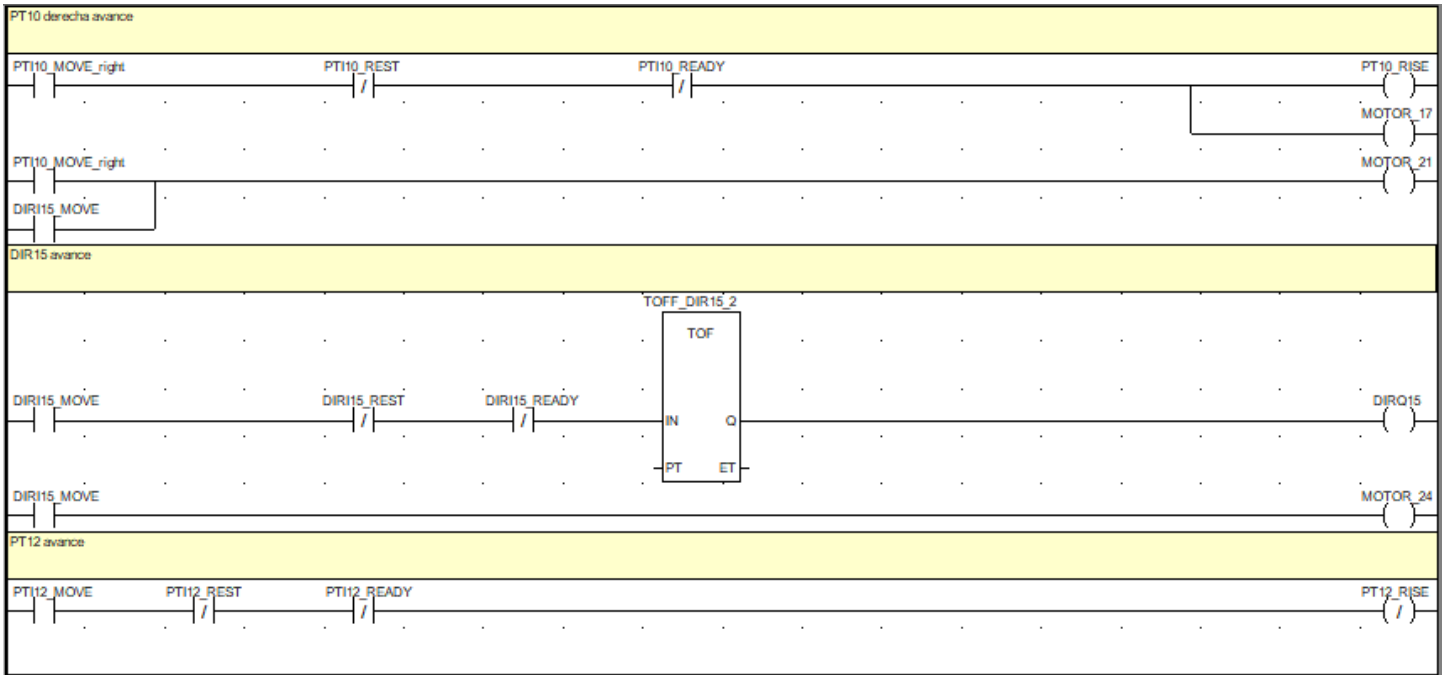

## Tracking:

```

IF (PTI08_MOVE AND %M80=FALSE) THEN

    %M80:=TRUE;

    IF (Import=FALSE) THEN
        ArrayPT08_PT09[C1_DIRI10]:=ArrayPT07_PT08[C1_DIRI10];
        C1_DIRI10:=C1_DIRI10+1;
    END_IF;
    IF (Import) THEN
        ArrayPT08_PT09[C1_DIRI10]:=ArrayPT08_INICIO[C1_DIRI10];
        C1_DIRI10:=C1_DIRI10+1;
    END_IF;

END_IF;

IF (PTI08_MOVE=FALSE) THEN
%M80:=FALSE;
END_IF;

IF (PTI09_READY AND %M81=FALSE) THEN

    %M81:=TRUE;
    IF (C1_DIRI10=PIEZAS_TOTALES) THEN
        C1_DIRI10:=0;
    END_IF;
END_IF;

IF (PTI09_READY=FALSE) THEN
%M81:=FALSE;
END_IF;

IF (PTI09_MOVE AND %M82=FALSE) THEN

    %M82:=TRUE;
    ArrayPT09_PT10[C3_DIRI11]:=ArrayPT08_PT09[C2_PTI09];
    C2_PTI09:=C2_PTI09+1;
    C3_DIRI11:=C3_DIRI11+1;
    IF (C2_PTI09=PIEZAS_TOTALES) THEN
        C2_PTI09:=0;
    END_IF;

END_IF;

IF (PTI09_MOVE=FALSE) THEN
%M82:=FALSE;
END IF;

```

```

IF (PTI09_MOVE_right AND %M83=FALSE ) THEN

    %M83:=TRUE;
    ArrayPT09_PT12[C6_DIRI14]:=ArrayPT08_PT09[C2_PTIO9];
    C2_PTIO9:=C2_PTIO9+1;
    C6_DIRI14:=C6_DIRI14+1;
    IF (C2_PTIO9=PIEZAS_TOTALES) THEN
        C2_PTIO9:=0;
    END_IF;

END_IF ;

IF (PTI09_MOVE_right=FALSE) THEN
%M83:=FALSE;
END_IF;

IF (PTI10_READY AND %M84=FALSE) THEN

    %M84:=TRUE;
    IF (C3_DIRI11=PIEZAS_TOTALES) THEN
        C3_DIRI11:=0;
    END_IF;

END_IF;

IF (PTI10_READY=FALSE) THEN
%M84:=FALSE;
END_IF;

IF (PTI10_MOVE AND %M85=FALSE) THEN

    %M85:=TRUE;
    ArrayPT10_PT14[C5_DIRI13]:=ArrayPT09_PT10[C4_PTIO10];
    C4_PTIO10:=C4_PTIO10+1;
    C5_DIRI13:=C5_DIRI13+1;
    IF (C4_PTIO10=PIEZAS_TOTALES) THEN
        C4_PTIO10:=0;
    END_IF;

END_IF;

IF (PTI10_MOVE=FALSE) THEN
%M85:=FALSE;
END_IF;

```

```

IF (PTI10_MOVE_right AND %M86=FALSE) THEN

    %M86:=TRUE;
    ArrayPT10_PT12[C8_DIRI15]:=ArrayPT09_PT10[C4_PTI10];
    C4_PTI10:=C4_PTI10+1;
    C8_DIRI15:=C8_DIRI15+1;
    IF (C4_PTI10=PIEZAS_TOTALES) THEN
        C4_PTI10:=0;
    END_IF;

END_IF;

IF (PTI10_MOVE_right=FALSE) THEN
%M86:=FALSE;
END_IF;

IF (DIRI15_MOVE AND %M87=FALSE ) THEN

    %M87:=TRUE;
    ArrayPT12_PT14[C11_PT12_salida]:=ArrayPT10_PT12[C9_PTI12];
    C9_PTI12:=C9_PTI12+1;
    IF (C8_DIRI15=PIEZAS_TOTALES) THEN
        C8_DIRI15:=0;
    END_IF;

END_IF;

IF (DIRI15_MOVE=FALSE) THEN
%M87:=FALSE;
END_IF;

IF (DIRI17_MOVE AND %M89=FALSE) THEN

    %M89:=TRUE;
    ArrayPT12_PT14[C11_PT12_salida]:=ArrayPT09_PT12[C7_DIRI17];
    C7_DIRI17:=C7_DIRI17+1;
    IF (C6_DIRI14=PIEZAS_TOTALES) THEN
        C6_DIRI14:=0;
    END_IF;

END_IF;

IF (DIRI17_MOVE=FALSE) THEN
%M89:=FALSE;
END_IF;

```



```

IF (PTI12_READY AND %M90=FALSE) THEN

    %M90:=TRUE;
    C11_PT12_salida:=C11_PT12_salida+1;
    IF (C9_PT12=PIEZAS_TOTALES) THEN
        C9_PT12:=0;
    END_IF;
    IF (C7_DIRI17=PIEZAS_TOTALES) THEN
        C7_DIRI17:=0;
    END_IF;

END_IF;

IF (PTI12_READY=FALSE) THEN
%M90:=FALSE;
END_IF;

IF (PTI12_MOVE AND %M91=FALSE) THEN

    %M91:=TRUE;
    IF (C11_PT12_salida=PIEZAS_TOTALES) THEN
        C11_PT12_salida:=0;
    END_IF;
END_IF;

IF (PTI12_MOVE=FALSE) THEN
%M91:=FALSE;
END_IF;

IF (DIRI19_MOVE AND %M92=FALSE) THEN

    %M92:=TRUE;
    ArrayPT14_PT15[C13_PT14_salida]:=ArrayPT12_PT14[C10_DIRI19];
    C10_DIRI19:=C10_DIRI19+1;
    IF (C10_DIRI19=PIEZAS_TOTALES) THEN
        C10_DIRI19:=0;
    END_IF;

END_IF;

IF (DIRI19_MOVE=FALSE) THEN
%M92:=FALSE;
END_IF;

```

```

IF (DIRI13_MOVE AND %M93=FALSE) THEN

    %M93:=TRUE;
    ArrayPT14_PT15[C13_PT14_salida]:=ArrayPT10_PT14[C12_PTI14];
    C12_PTI14:=C12_PTI14+1;
    IF (C5_DIRI13=PIEZAS_TOTALES) THEN
        C5_DIRI13:=0;
    END_IF;

END_IF;

IF (DIRI13_MOVE=FALSE) THEN
%M93:=FALSE;
END_IF;

IF (PTI14_READY AND %M95=FALSE) THEN

    %M95:=TRUE;
    IF (C12_PTI14=PIEZAS_TOTALES) THEN
        C12_PTI14:=0;
    END_IF;

END_IF;

IF (PTI14_READY=FALSE) THEN
%M95:=FALSE;
END_IF;

IF (PTI14_MOVE AND %M96=FALSE) THEN

    %M96:=TRUE;
    IF (ArrayPT14_PT15[C13_PT14_salida]=PIEZA) THEN
        %MW375:=PIEZA;
        IF (PIEZA=PIEZAS_TOTALES) THEN
            PIEZA:=1;
        ELSE
            IF (PIEZA<PIEZAS_TOTALES) THEN
                PIEZA:=PIEZA+1;
            END_IF;
        END_IF;
    END_IF;
    C13_PT14_salida:=C13_PT14_salida+1;
    IF (C13_PT14_salida=PIEZAS_TOTALES) THEN
        C13_PT14_salida:=0;
    END_IF;
END_IF;

END_IF;

IF (PTI14_MOVE=FALSE) THEN
%M96:=FALSE;
END_IF;

```

## Ordering:

```

IF (PTI09_READY AND ArrayPT08_PT09[C2_PTI09]=PIEZA) THEN
  Continuar_recto_PT09:=TRUE;
ELSE
  IF (DIRI10_READY AND PTI09_READY) THEN
    IF (ArrayPT08_PT09[C2_PTI09]>ArrayPT08_PT09[C1_DIRI10-1]) THEN
      Girar_derecha_PT09:=TRUE;
    ELSE
      Continuar_recto_PT09:=TRUE;
    END_IF;
  END_IF;
END_IF;

IF (PTI09_MOVE OR PTI09_MOVE_right) THEN
  Girar_derecha_PT09:=FALSE;
  Continuar_recto_PT09:=FALSE;
END_IF;

IF (PTI10_READY AND ArrayPT09_PT10[C4_PTI10]=PIEZA) THEN
  Continuar_recto_PT10:=TRUE;
ELSE
  IF (DIRI12_READY AND PTI10_READY) THEN
    IF (ArrayPT09_PT10[C4_PTI10]>ArrayPT09_PT10[C3_DIRI11-1]) THEN
      Girar_derecha_PT10:=TRUE;
    ELSE
      Continuar_recto_PT10:=TRUE;
    END_IF;
  END_IF;
END_IF;

IF (PTI10_MOVE OR PTI10_MOVE_right) THEN
  Girar_derecha_PT10:=FALSE;
  Continuar_recto_PT10:=FALSE;
END_IF;

IF (DIRI15_READY AND ArrayPT10_PT12[C9_PTI12]=PIEZA) THEN
  Prioridad_DIR15:=TRUE;
ELSE
  IF (DIRI17_READY AND ArrayPT09_PT12[C7_DIRI17]=PIEZA) THEN
    Prioridad_DIR17:=TRUE;
  ELSE
    IF (DIRI17_READY AND DIRI15_READY AND PTI12_REST) THEN
      IF (ArrayPT09_PT12[C7_DIRI17]>ArrayPT10_PT12[C9_PTI12]) THEN
        Prioridad_DIR15:=TRUE;
      ELSE
        IF (ArrayPT09_PT12[C7_DIRI17]>ArrayPT10_PT12[C9_PTI12]) THEN
          Prioridad_DIR17:=TRUE;
        END_IF;
      END_IF;
    END_IF;
  END_IF;
END_IF;

IF ((DIRI17_MOVE OR DIRI15_MOVE)) THEN
  Prioridad_DIR17:=FALSE;
  Prioridad_DIR15:=FALSE;
END_IF;

```

```

IF (DIRI13_READY AND ArrayPT10_PT14[C12_PTI14]=PIEZA) THEN
  Prioridad_DIR13:=TRUE;
ELSE
  IF (DIRI19_READY AND ArrayPT12_PT14[C10_DIRI19]=PIEZA) THEN
    Prioridad_DIR19:=TRUE;
  ELSE
    IF (DIRI19_READY AND DIRI13_READY AND PTI14_REST) THEN
      IF (ArrayPT10_PT14[C12_PTI14]>ArrayPT12_PT14[C10_DIRI19]) THEN
        Prioridad_DIR19:=TRUE;
      ELSE
        IF (ArrayPT12_PT14[C10_DIRI19]>ArrayPT10_PT14[C12_PTI14]) THEN
          Prioridad_DIR13:=TRUE;
        END_IF;
      END_IF;
    END_IF;
  END_IF;
END_IF;

IF ((DIRI19_MOVE OR DIRI13_MOVE)) THEN
  Prioridad_DIR19:=FALSE;
  Prioridad_DIR13:=FALSE;
END_IF;

```

## LINEA CAN:

### Reset:

```
%MW510:=contador_pulmon;

IF %S13 THEN

    Array_vacia[0]:=0;
    Array_vacia[1]:=0;
    Array_vacia[2]:=0;
    Array_vacia[3]:=0;
    Array_vacia[4]:=0;
    Array_vacia[5]:=0;
    Array_vacia[6]:=0;
    Array_vacia[7]:=0;
    Array_vacia[8]:=0;
    Array_vacia[9]:=0;

    DIR03_REST := TRUE;
    DIR03_READY := FALSE;
    DIR03_MOVE := FALSE;
    PT04_REST := TRUE;
    PT04_READY := FALSE;
    PT04_MOVE := FALSE;
    DIR04_REST := TRUE;
    DIR04_READY := FALSE;
    DIR04_MOVE := FALSE;
    PT05_REST := TRUE;
    PT05_READY := FALSE;

    PT05_MOVE := FALSE;
    DIR05_REST := TRUE;
    DIR05_READY := FALSE;
    DIR05_MOVE := FALSE;
    DIR08_REST := TRUE;
    DIR08_READY := FALSE;
    DIR08_MOVE := FALSE;
    PT17_REST := TRUE;
    PT17_READY := FALSE;
    PT17_MOVE := FALSE;
    DIR21_REST := TRUE;
    DIR21_READY := FALSE;
    DIR21_MOVE := FALSE;
    PT07_REST := TRUE;
    PT07_READY := FALSE;
    PT07_MOVE := FALSE;
    PT15_REST := TRUE;
    PT15_READY := FALSE;
    PT15_MOVE := FALSE;
    DIR20_REST := TRUE;
    DIR20_READY := FALSE;
    DIR20_MOVE := FALSE;
    PT16_REST := TRUE;
    PT16_READY := FALSE;
    PT16_MOVE := FALSE;
```

```

PT06_REST := TRUE;
PT06_READY := FALSE;
PT06_MOVE := FALSE;
DIR09_REST := TRUE;
DIR09_READY := FALSE;
DIR09_MOVE := FALSE;
DIR07_REST := TRUE;
DIR07_READY := FALSE;
DIR07_MOVE := FALSE;
PT05_MOVE_left := FALSE;
PT16_MOVE_right := FALSE;

C0_DIRI03:=0;
C1_PTI04:=0;
C2_DIRI07:=0;
C3_DIRI20:=0;
C4_PTI16:=0;
C5_PTI17:=0;
C6_DIRI08:=0;
C7_DIRI21:=0;
C8_DIRI04:=0;
C9_PTI05:=0;
C10_DIRI05:=0;
C11_PTI07:=0;
C12_DIRI09:=0;
C13_PTI15:=0;
C14_PT17_salida:=0;
%MW510:=0;
END_IF;

IF (contador_pulmon=PIEZAS_TOTALES) THEN
  ArrayPT15_PT16:=Array_vacia;
  ArrayPT16_PT04:=Array_vacia;
  ArrayPT16_PT17:=Array_vacia;
  ArrayPT04_PT05:=Array_vacia;
  ArrayPT05_PT06:=Array_vacia;
  ArrayPT17_PT07:=Array_vacia;
  ArrayPT07_PT08:=Array_vacia;
  C0_DIRI03:=0;
  C1_PTI04:=0;
  C2_DIRI07:=0;
  C3_DIRI20:=0;
  C4_PTI16:=0;
  C5_PTI17:=0;
  C6_DIRI08:=0;
  C7_DIRI21:=0;
  C8_DIRI04:=0;
  C9_PTI05:=0;
  C10_DIRI05:=0;
  C11_PTI07:=0;
  C12_DIRI09:=0;
  C13_PTI15:=0;
  C14_PT17_salida:=0;
END_IF;

```



```
IF (Emergencia) THEN
    Estado_emergencia:=TRUE;
END_IF;
IF (Estado_emergencia AND Rearme) THEN
    Estado_emergencia:=FALSE;
END_IF;
```

**Cinta\_central:**

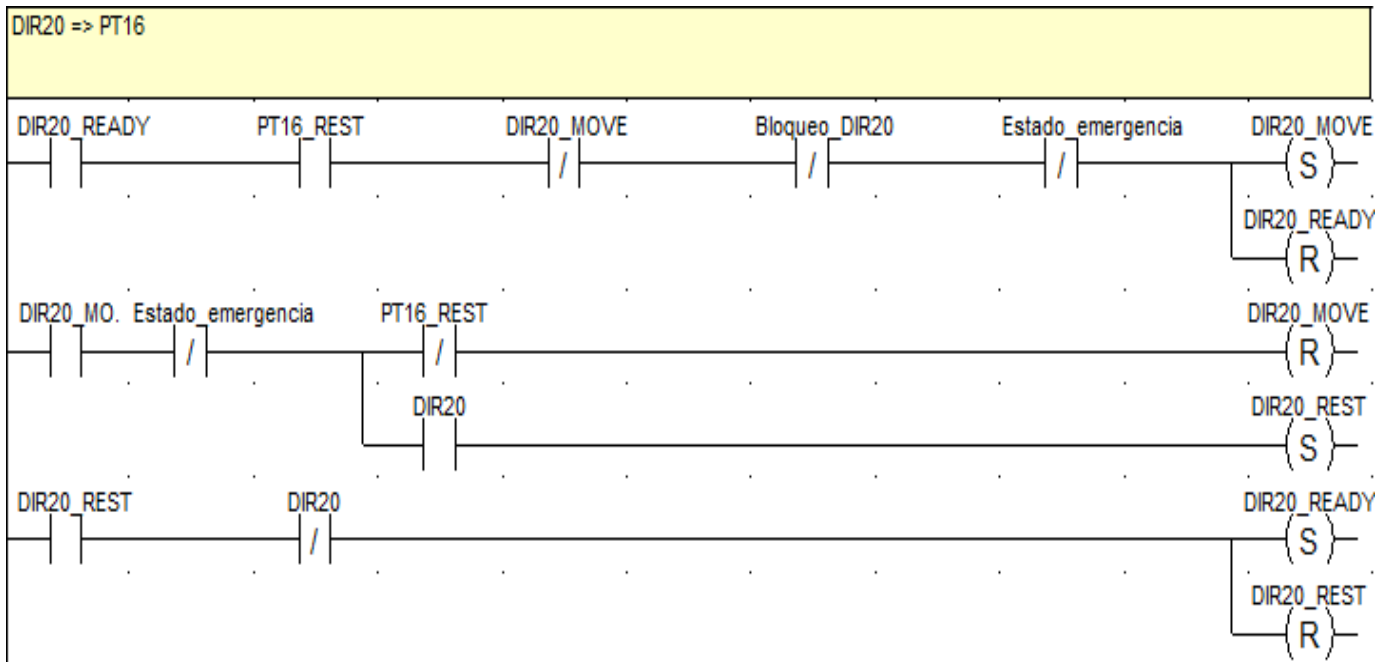
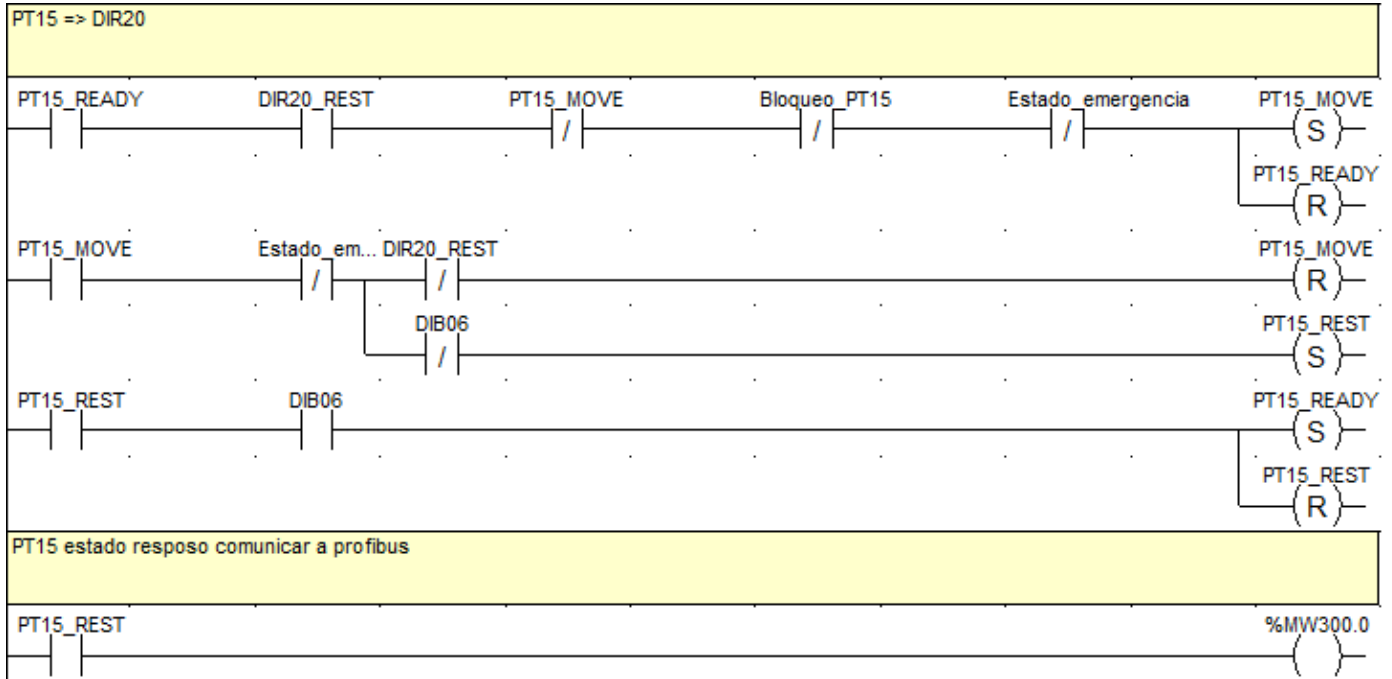



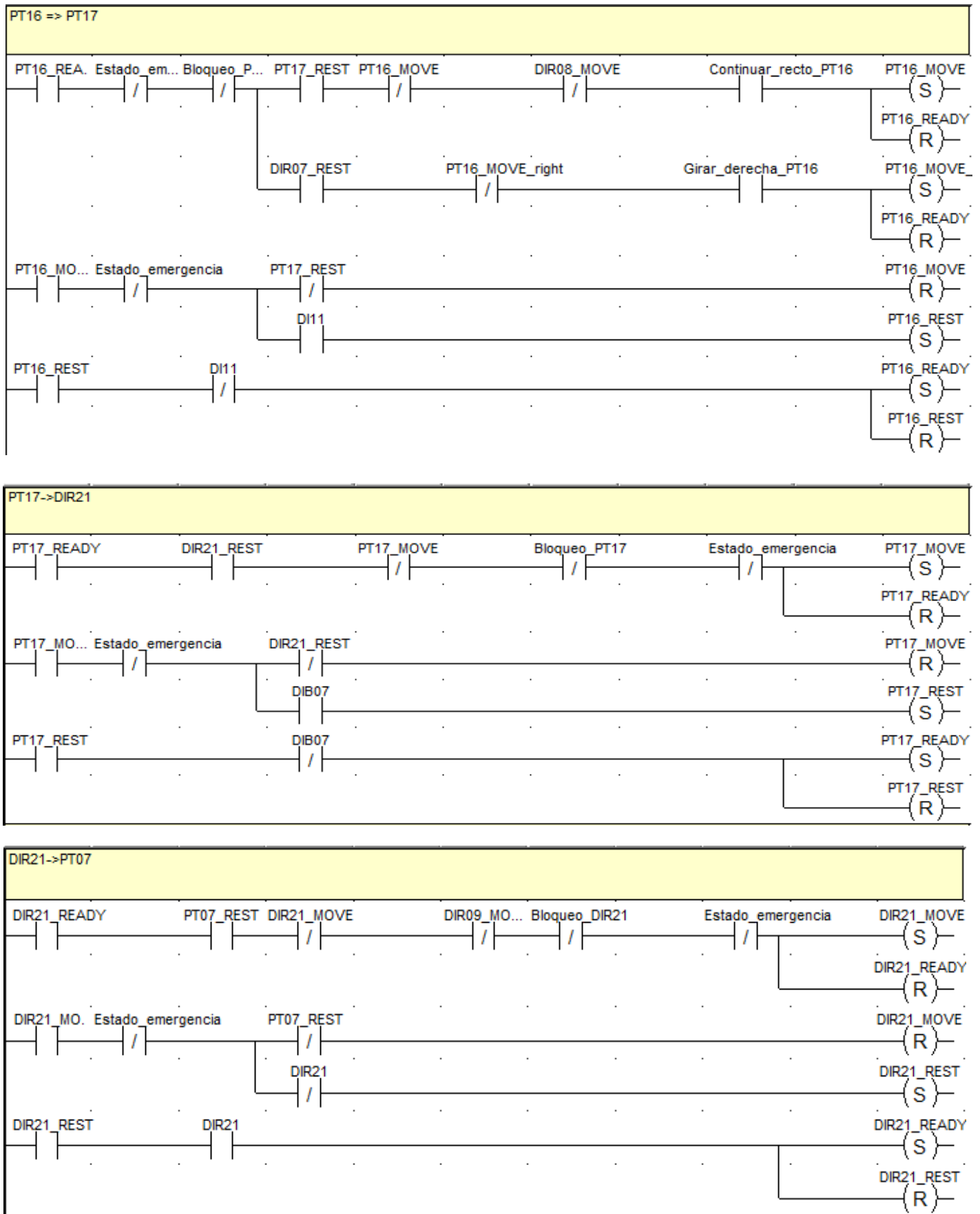

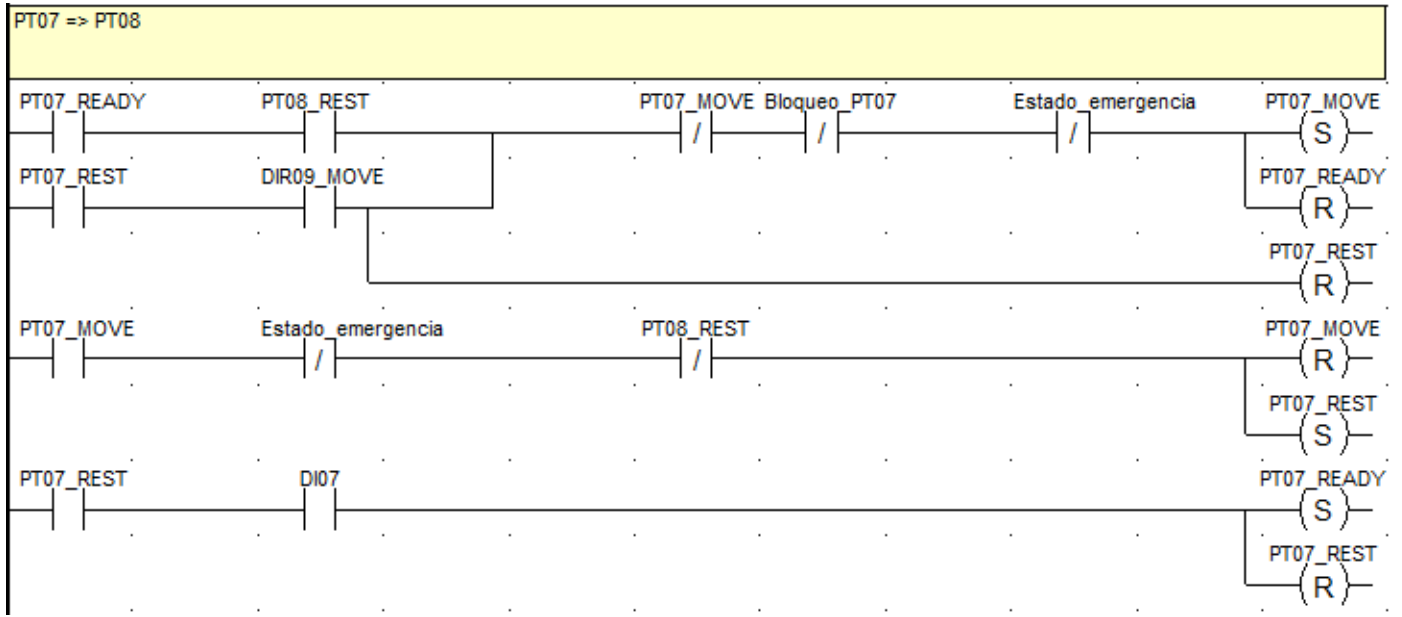

### Cinta\_izquierda1:

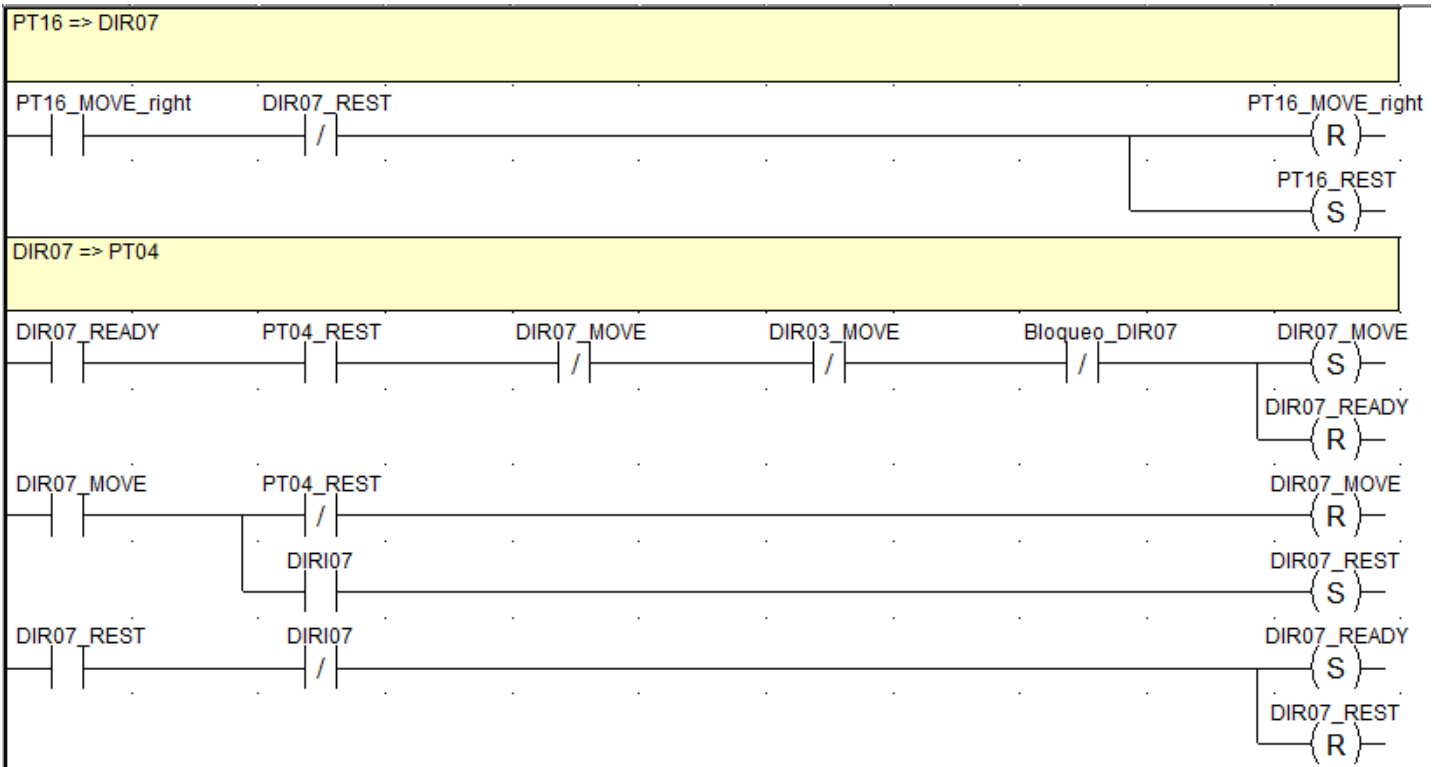
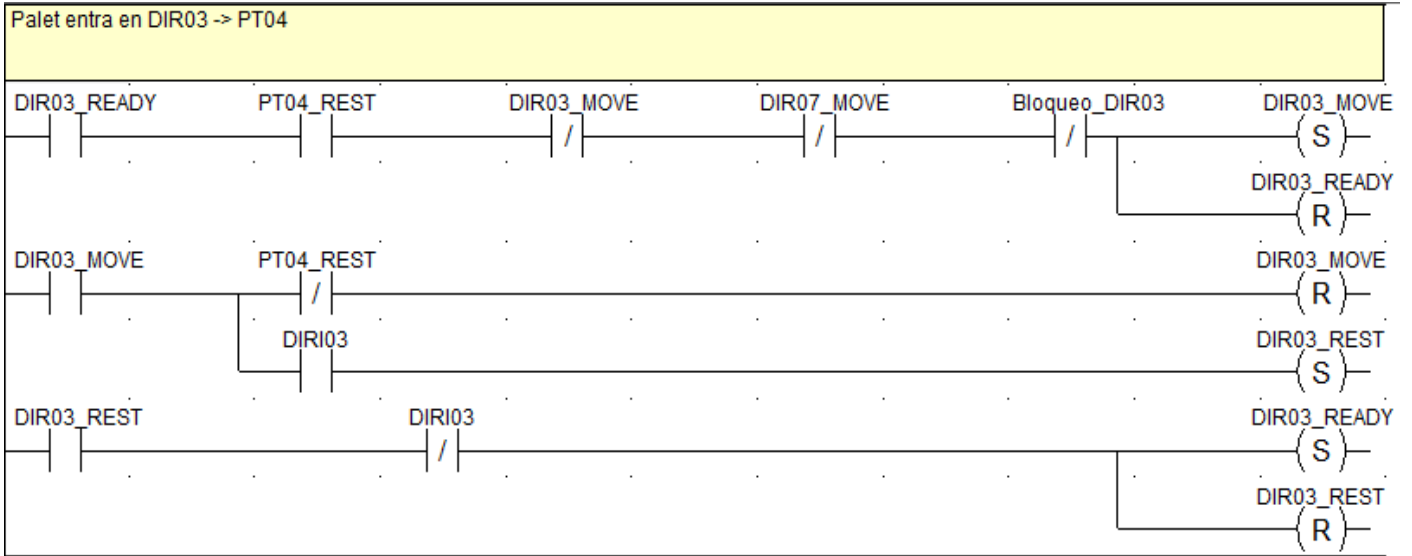

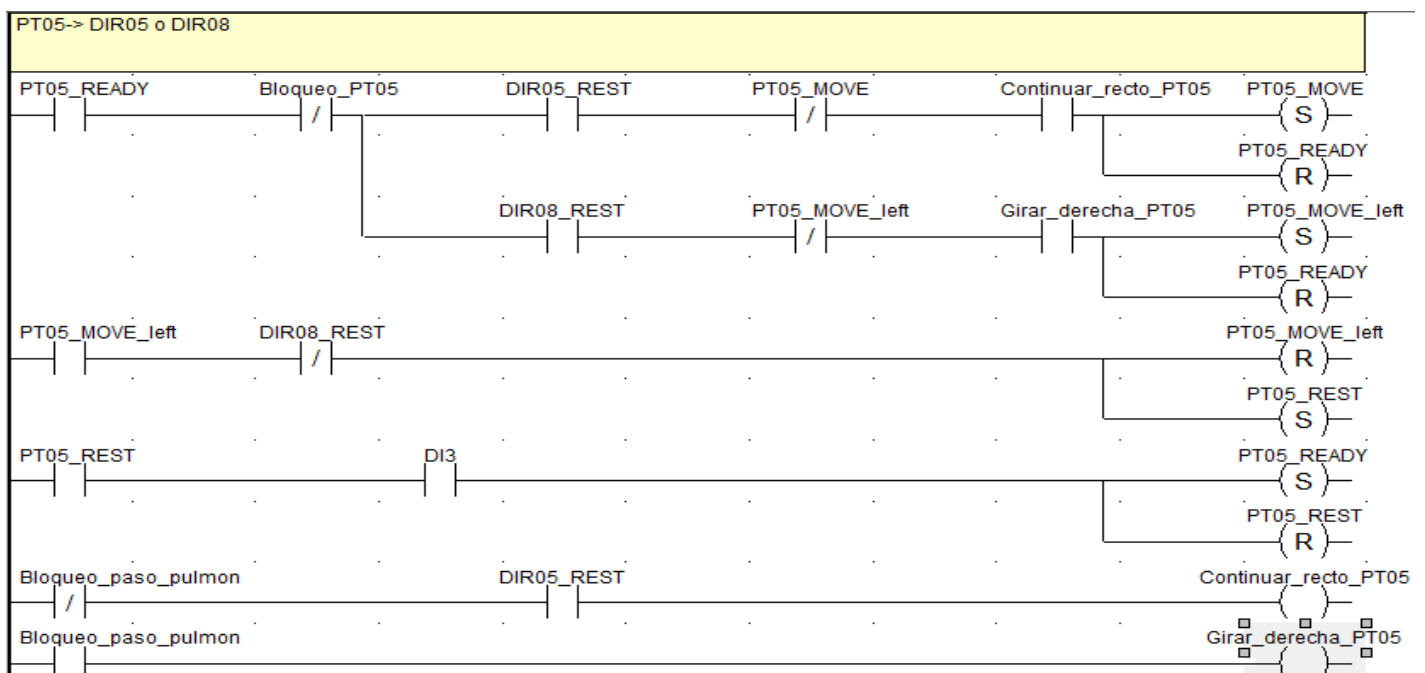
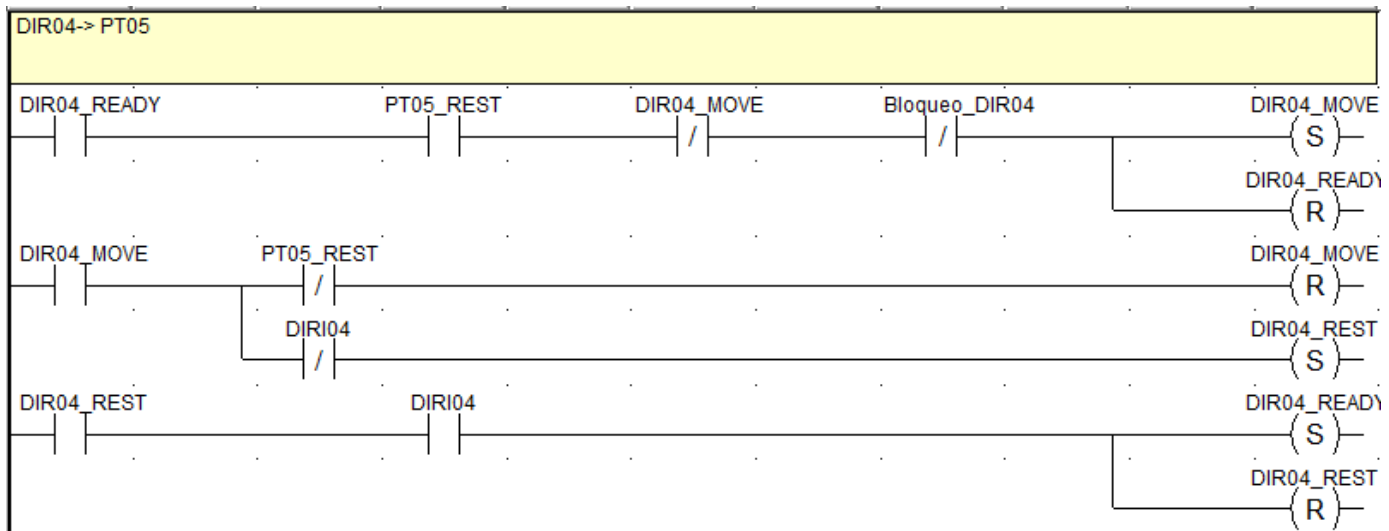
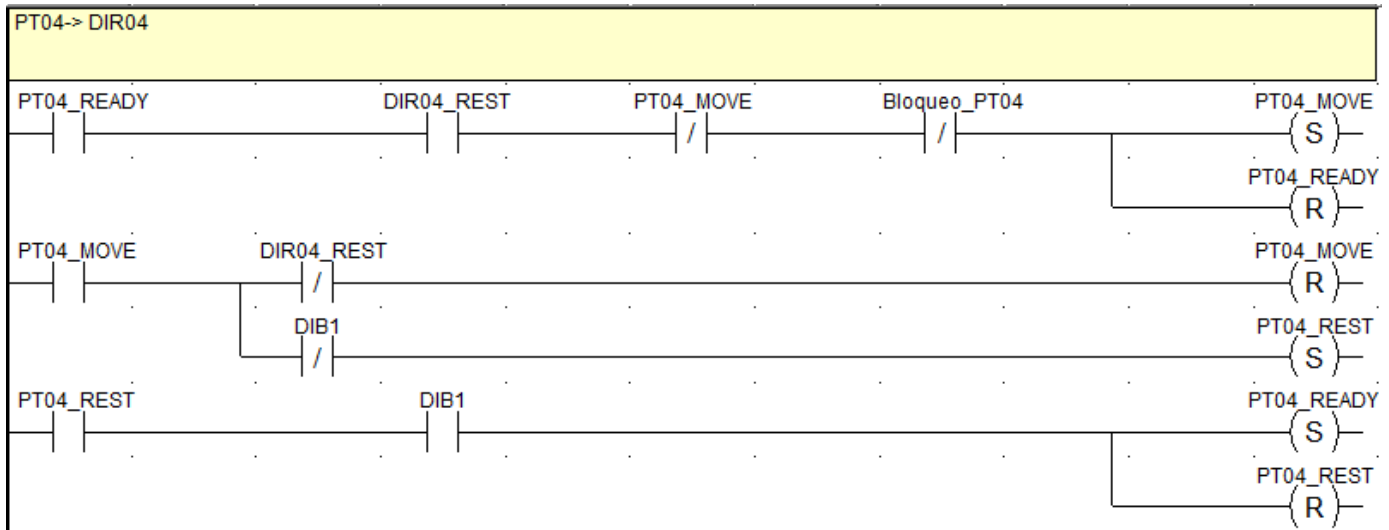

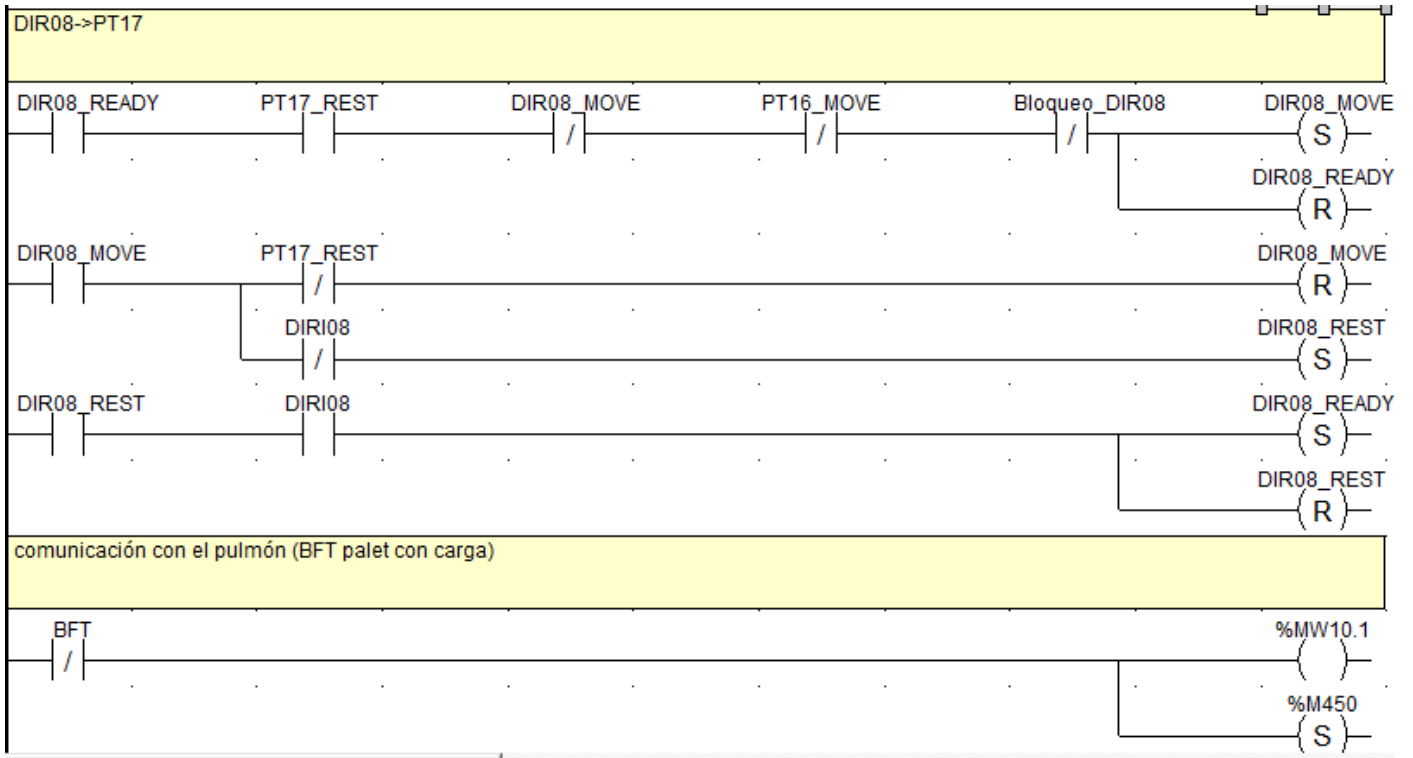

**Cinta\_izquierda2:**

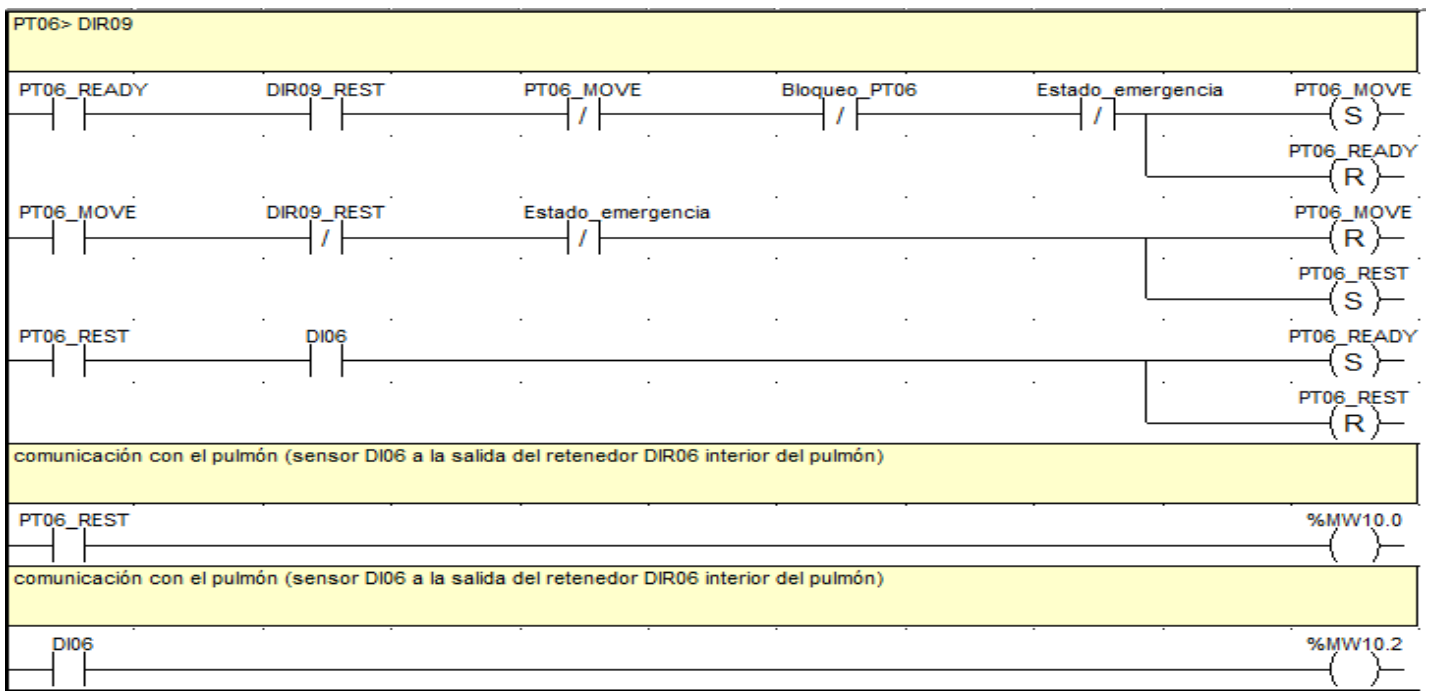
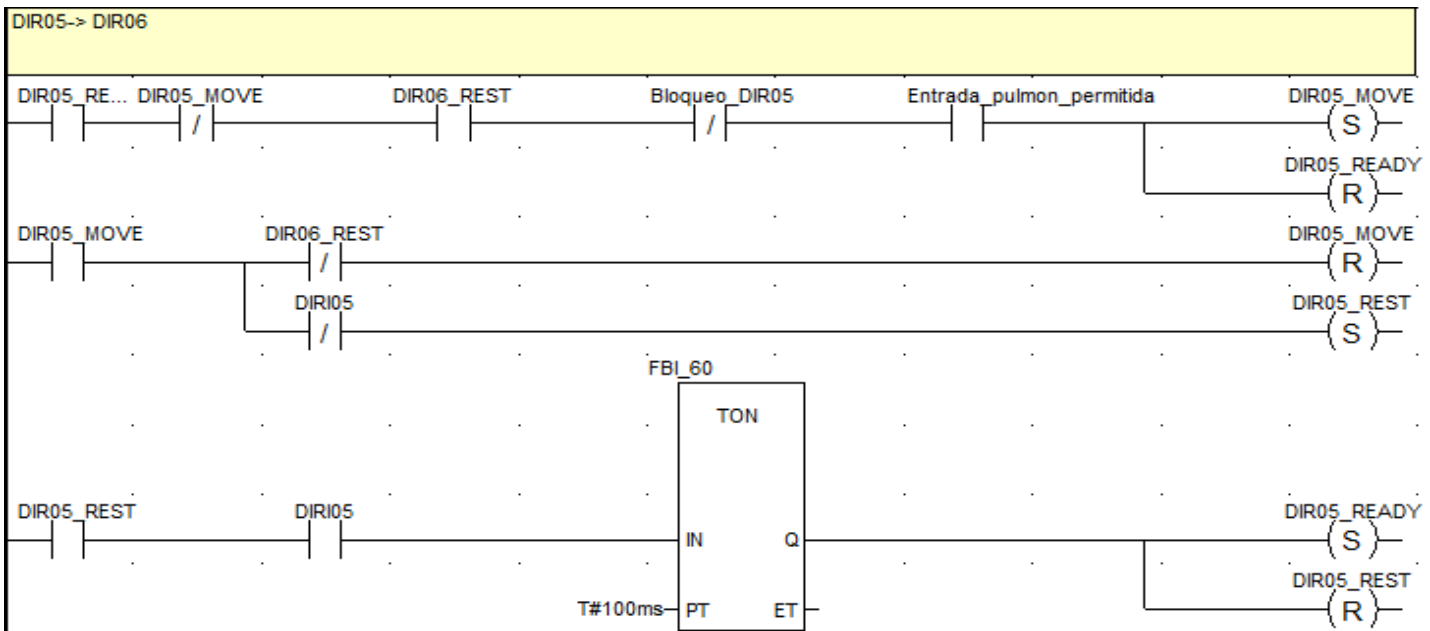
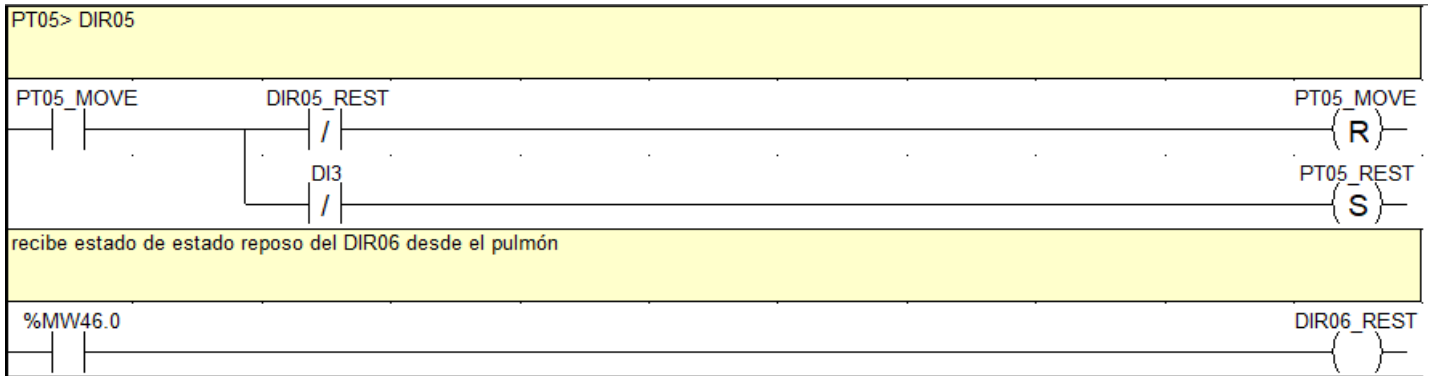

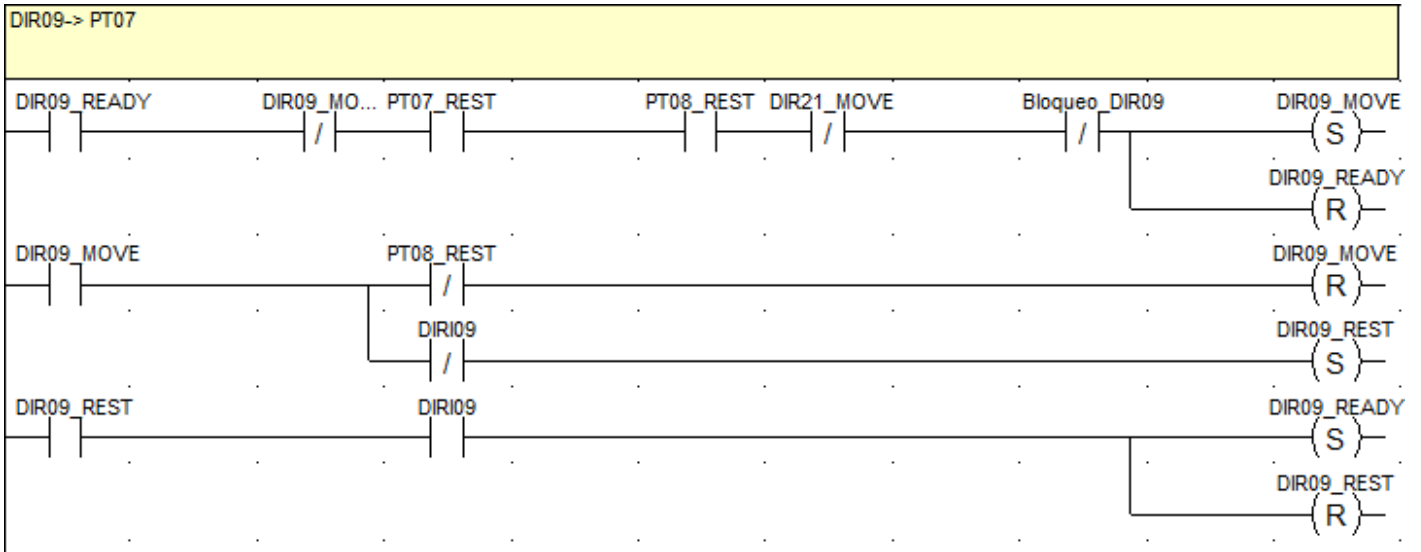

### Salidas\_central:

#### Activación cinta central

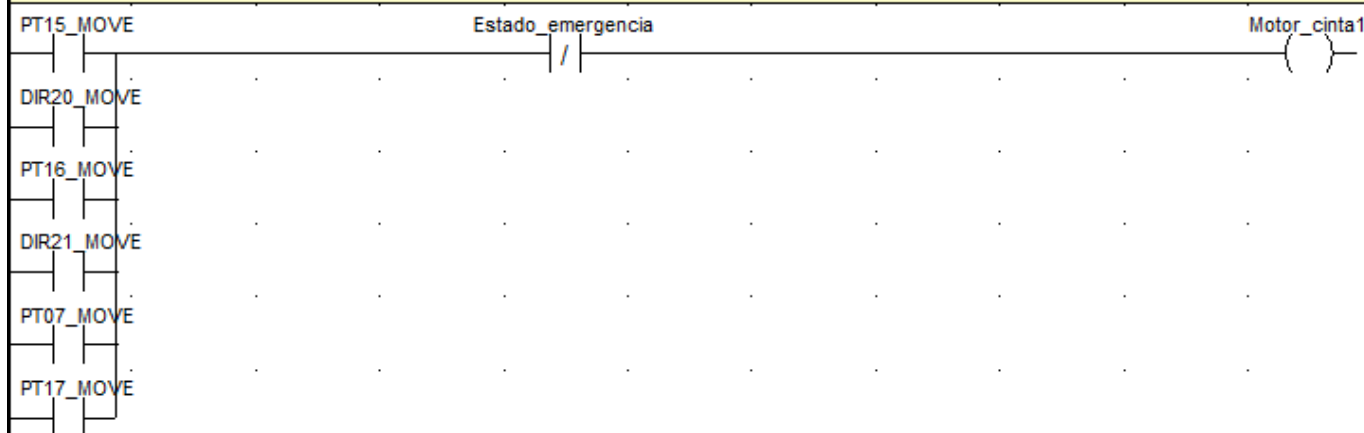

PT15-> bajar plataforma para que pueda moverse la bandeja siempre en estado avance unicamente No puede haber otro estado a la vez.

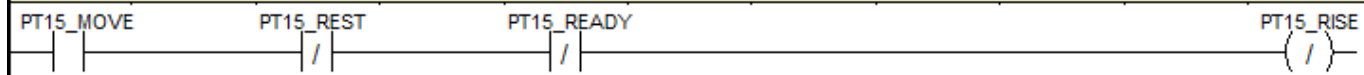

#### DIR20-> bajar retenedor para dejar pasar bandeja en el estado de avance

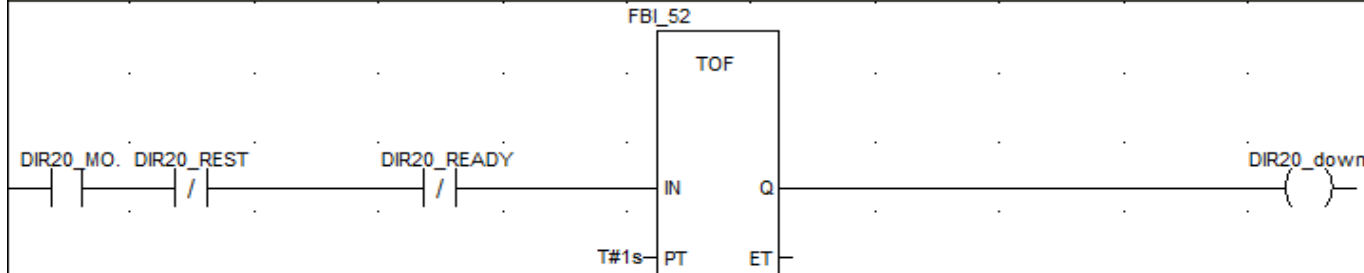

#### PT16-> bajar plataforma en avance

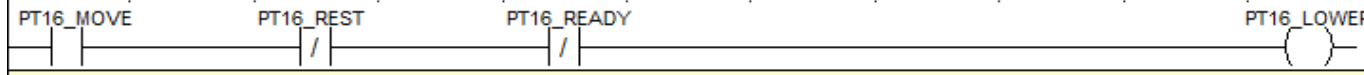

#### PT17-> bajar plataforma en avance

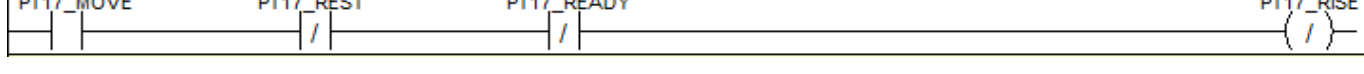

#### DIR21-> bajar retenedor para dejar pasar bandeja en el estado de avance

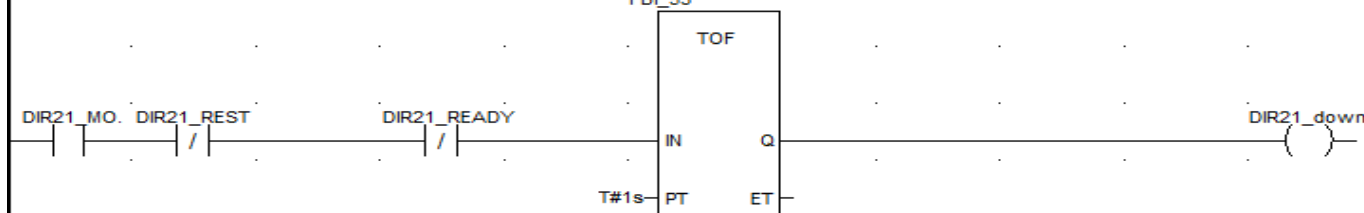

#### PT07-> subir la plataforma en avance, ya que esta plataforma solo se mueve en estado de subida.

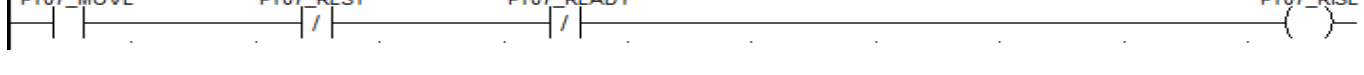



### Salidas\_izquierda1:

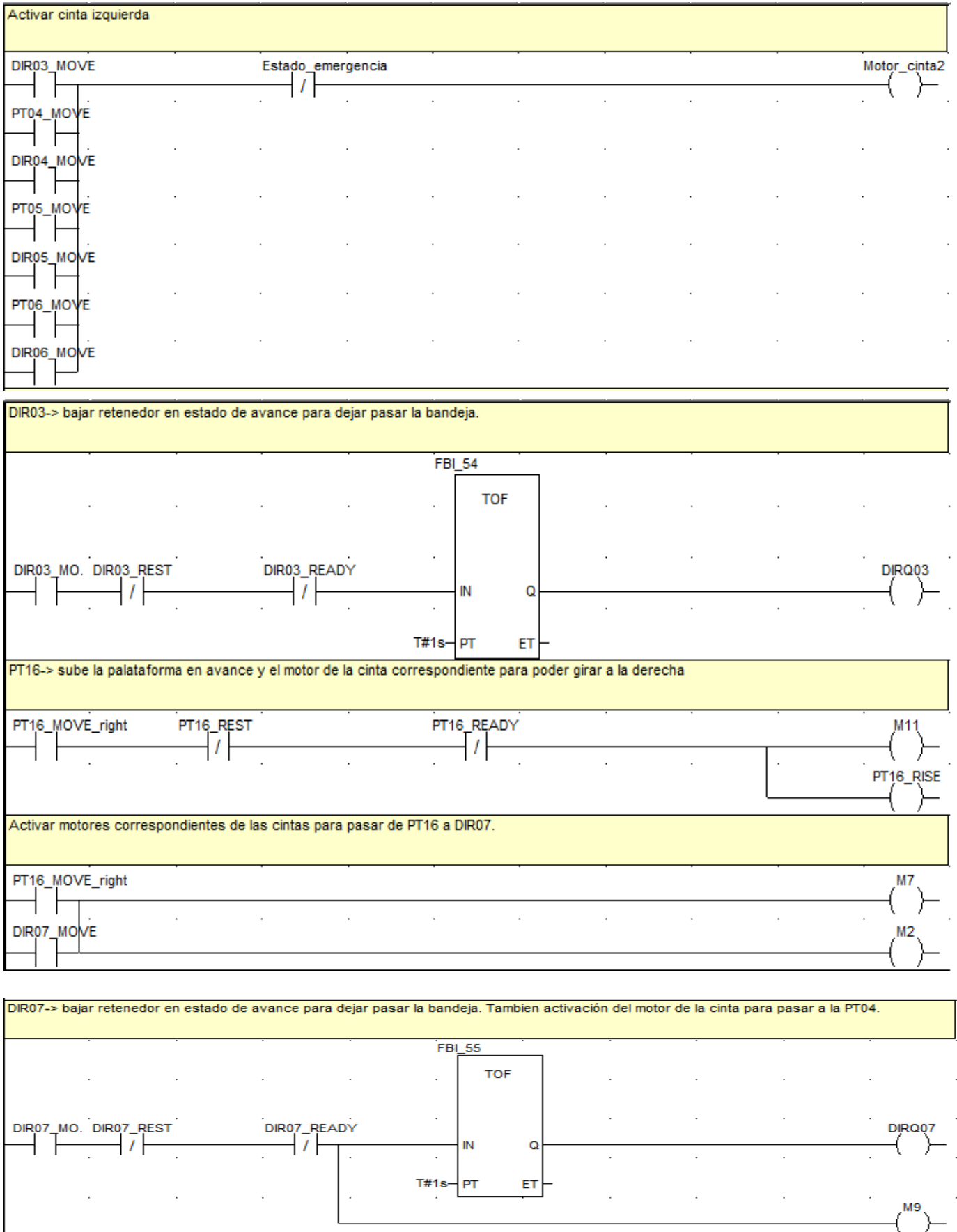

PT04-> bajar plataforma en estado de avance



DIR04-> bajar retenedor en estado de avance para dejar pasar la bandeja.

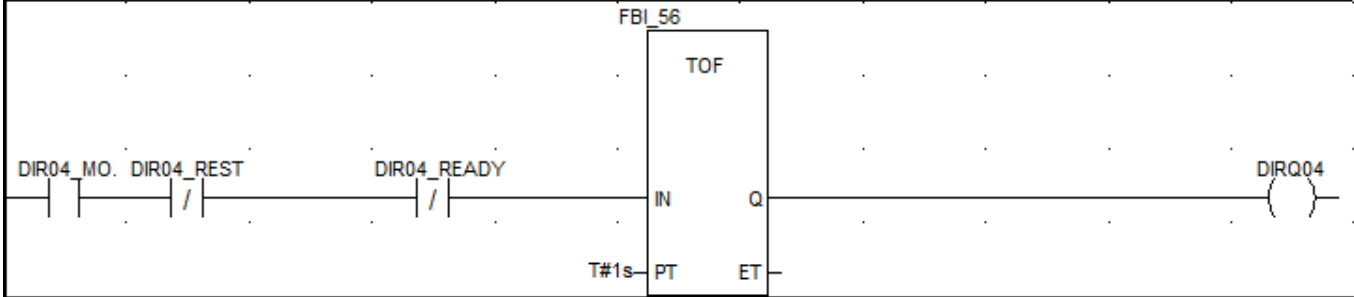

PT05-> sube plataforma en estado de avance para girar a la derecha. Acovación de los motores de las cintas correspondientes para llegar a DIR08

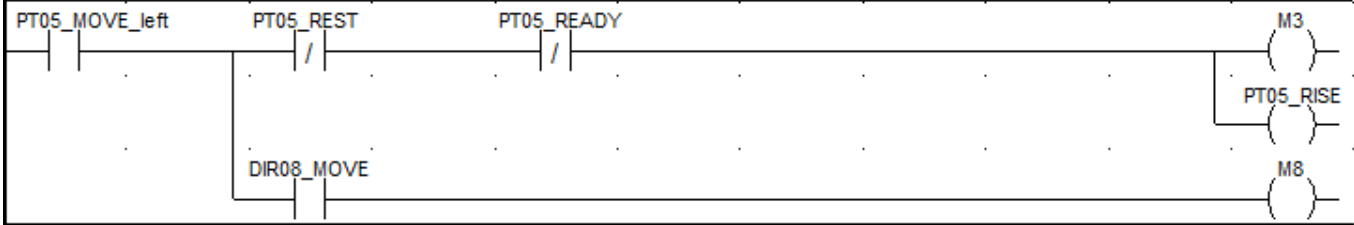

DIR08-> bajar retenedor en estado de avance. Activación motor cinta para llegar a la siguiente plataforma (PT17).

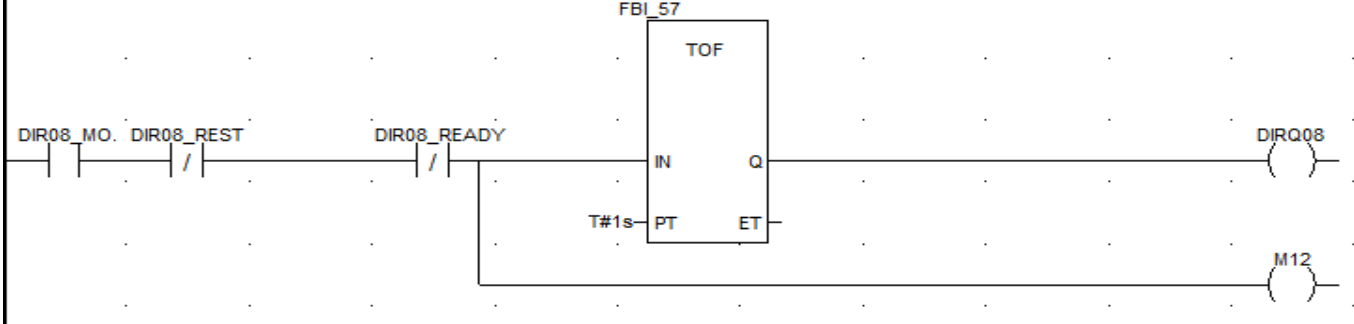

### Salidas\_izquierda2:

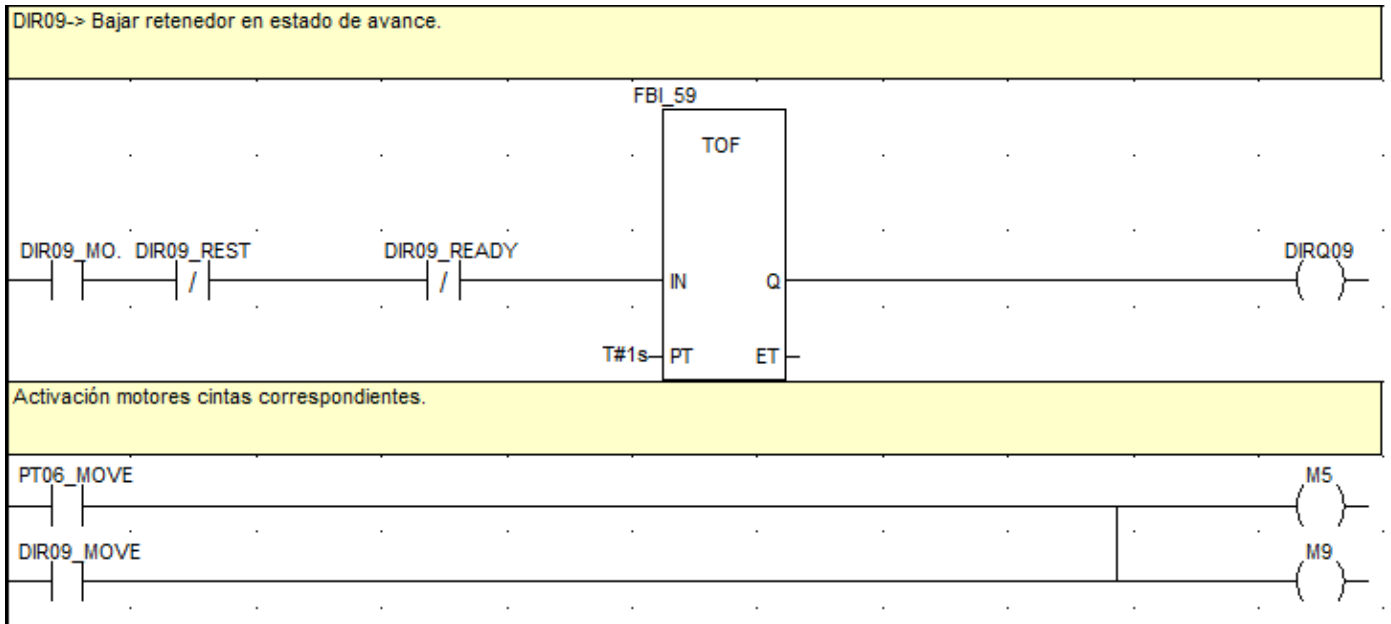
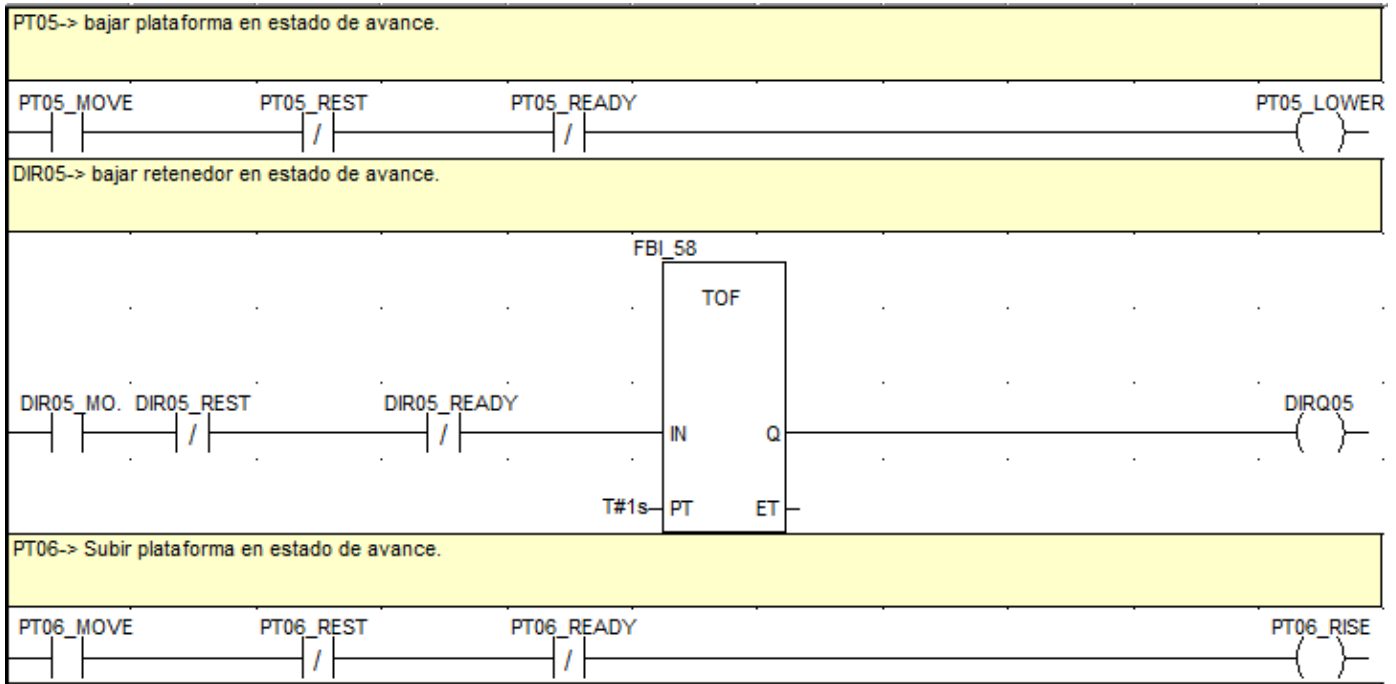

## Tracking:

```

IF (PT15_MOVE AND %M365=FALSE) THEN
    %M365:=TRUE;
    ArrayPT15_PT16[C13_PTI15]:=ArrayPT14_PT15[C13_PTI15];
    C13_PTI15:=C13_PTI15+1;
    IF (C13_PTI15=PIEZAS_TOTALES) THEN
        C13_PTI15:=0;
    END_IF;
END_IF;

IF (PT15_MOVE=FALSE) THEN
%M365:=FALSE;
END_IF;

IF (PT16_READY AND %M366=FALSE ) THEN
    %M366:=TRUE;
    IF (C3_DIRI20=PIEZAS_TOTALES) THEN
        C3_DIRI20:=0;
    END_IF;
    IF (ArrayPT15_PT16[C4_PTI16]=PIEZA) THEN
        Girar_derecha_PT16:=TRUE;
    ELSE
        IF (ArrayPT15_PT16[C4_PTI16]<>PIEZA) THEN
            Continuar_recto_PT16:=TRUE;
        END_IF;
    END_IF;
END_IF ;

IF (PT16_READY=FALSE) THEN
%M366:=FALSE;
END_IF;

IF (PT16_MOVE AND %M367=FALSE ) THEN
    %M367:=TRUE;
    Girar_derecha_PT16:=FALSE;
    Continuar_recto_PT16:=FALSE;
    ArrayPT16_PT17[C5_PTI17]:=ArrayPT15_PT16[C4_PTI16];
    C4_PTI16:=C4_PTI16+1;
    ArrayPT17_PT07[C14_PT17_salida]:= ArrayPT16_PT17[C5_PTI17];
    C5_PTI17:=C5_PTI17+1;
    IF (C4_PTI16=PIEZAS_TOTALES) THEN
        C4_PTI16:=0;
    END_IF;
END_IF ;

IF (PT16_MOVE=FALSE) THEN
%M367:=FALSE;
END_IF;

IF (PT16_MOVE_right AND %M368=FALSE) THEN
    %M368:=TRUE;
    ArrayPT16_PT04[C2_DIRI07]:=ArrayPT15_PT16[C4_PTI16];
    C4_PTI16:=C4_PTI16+1;
    C2_DIRI07:=C2_DIRI07+1;
END_IF ;

```

```

IF (PT16_MOVE_right=FALSE) THEN
%M368:=FALSE;
END_IF;

IF (PT04_READY AND %M360=FALSE ) THEN
  %M360:=TRUE;
  IF (C2_DIRI07=PIEZAS_TOTALES) THEN
    C2_DIRI07:=0;
  END_IF;
END_IF ;

IF (PT04_READY=FALSE) THEN
%M360:=FALSE;
END_IF;

IF (PT04_MOVE AND %M361=FALSE ) THEN
  %M361:=TRUE;
  ArrayPT04_PT05[C8_DIRI04]:= ArrayPT16_PT04[C1_PTIO4];
  C1_PTIO4:=C1_PTIO4+1;
  C8_DIRI04:=C8_DIRI04+1;
  IF (C1_PTIO4=PIEZAS_TOTALES) THEN
    C1_PTIO4:=0;
  END_IF;
END_IF ;

IF (PT04_MOVE=FALSE) THEN
%M361:=FALSE;
END_IF;

IF (PT05_READY AND %M362=FALSE ) THEN
  %M362:=TRUE;
  IF (C8_DIRI04=PIEZAS_TOTALES) THEN
    C8_DIRI04:=0;
  END_IF;
END_IF ;

IF (PT05_READY=FALSE) THEN
%M362:=FALSE;
END_IF;

IF (PT05_MOVE AND %M363=FALSE ) THEN
  %M363:=TRUE;
  ArrayPT05_PT06[C10_DIRI05]:= ArrayPT04_
  C9_PTIO5:=C9_PTIO5+1;
  C10_DIRI05:=C10_DIRI05+1;
  IF (C9_PTIO5=PIEZAS_TOTALES) THEN
    C9_PTIO5:=0;
  END_IF;
END_IF ;

IF (PT05_MOVE=FALSE) THEN
%M363:=FALSE;
END_IF;

```

```

IF (PT05_MOVE_left AND %M364=FALSE) THEN
  %M364:=TRUE;
  ArrayPT05_PT17[C6_DIRI08]:=ArrayPT04_PT05[C9_PTI05];
  C9_PTI05:=C9_PTI05+1;
  C6_DIRI08:=C6_DIRI08+1;
  IF (C9_PTI05=PIEZAS_TOTALES) THEN
    C9_PTI05:=0;
  END_IF;
END_IF ;

IF (PT05_MOVE_left=FALSE) THEN
%M364:=FALSE;
END_IF;

IF (DIR08_MOVE AND %M370=FALSE) THEN
  %M370:=TRUE;
  ArrayPT17_PT07[C14_PT17_salida]:= ArrayPT05_PT17[C5_PTI17];
  C5_PTI17:=C5_PTI17+1;
  IF (C6_DIRI08=PIEZAS_TOTALES) THEN
    C6_DIRI08:=0;
  END_IF;
END_IF ;

IF (DIR08_MOVE=FALSE) THEN
%M370:=FALSE;
END_IF;

IF (PT17_MOVE AND %M371=FALSE) THEN
  %M371:=TRUE;
  C14_PT17_salida:=C14_PT17_salida+1;
  IF (C5_PTI17=PIEZAS_TOTALES) THEN
    C5_PTI17:=0;
  END_IF;
  IF (C14_PT17_salida=PIEZAS_TOTALES) THEN
    C14_PT17_salida:=0;
  END_IF;
END_IF ;

IF (PT17_MOVE=FALSE) THEN
%M371:=FALSE;
END_IF;

IF (DIR21_MOVE AND %M372=FALSE) THEN
  %M372:=TRUE;
  ArrayPT07_PT08[C11_PTI07]:=ArrayPT17_PT07[C7_DIRI21];
  C7_DIRI21:=C7_DIRI21+1;
  IF (C7_DIRI21=PIEZAS_TOTALES) THEN
    C7_DIRI21:=0;
  END_IF;
END_IF ;

IF (DIR21_MOVE=FALSE) THEN
%M372:=FALSE;
END_IF;

IF (PT06_MOVE AND %M373=FALSE) THEN
  %M373:=TRUE;
  IF (C10_DIRI05=PIEZAS_TOTALES) THEN
    C10_DIRI05:=0;
  END_IF;
END_IF ;

```



```
IF (PT06_MOVE=FALSE) THEN
%M373:=FALSE;
END_IF;

IF (DIR09_MOVE AND %M374=FALSE) THEN
    %M374:=TRUE;
    ArrayPT07_PT08[C11_PTI07]:=ArrayPT06_INICIC[C12_DIRI09];
    C12_DIRI09:=C12_DIRI09+1;
    IF (C12_DIRI09=PIEZAS_TOTALES) THEN
        C12_DIRI09:=0;
    END_IF;
END_IF ;

IF (DIR09_MOVE=FALSE) THEN
%M374:=FALSE;
END_IF;

IF (PT07_MOVE AND %M375=FALSE) THEN
    %M375:=TRUE;
    C11_PTI07:=C11_PTI07+1;
    IF (C11_PTI07=PIEZAS_TOTALES) THEN
        C11_PTI07:=0;
    END_IF;
END_IF ;

IF (PT07_MOVE=FALSE) THEN
%M375:=FALSE;
END_IF;
```

## PULMÓN:

### Reset:

```

IF %S13 THEN
  PIEZAS_TOTALES:=3;
  Proceso:=TRUE;
  DIR06_REST:=TRUE;
  DIR06_READY:=FALSE;
  DIR06_MOVE:=FALSE;
  Bloqueo_DIR06:=TRUE;

  ArrayPT06_INICIC[0]:=3;
  ArrayPT06_INICIC[1]:=1;
  ArrayPT06_INICIC[2]:=2;

END_IF;

IF estado_emergencia THEN

  Etapa0 := FALSE;
  Etapa1 := FALSE;
  Etapa2 := FALSE;
  Etapa3 := FALSE;
  Etapa4 := FALSE;
  Etapa5 := FALSE;
  Etapa6 := FALSE;
  Etapa7 := FALSE;
  Etapa8 := FALSE;
  Etapa9 := FALSE;
  Etapa10 := FALSE;

END_IF;

```

### Alarmas:

alarma puerta 1 abierta			
Puerta1	%M150	Marca_puerta1	(S)
Puerta1	Rearme	Marca_puerta1	(R)
alarma puerta 2 abierta			
Puerta2	%M150	Marca_puerta2	(S)
Puerta2	Rearme	Marca_puerta2	(R)



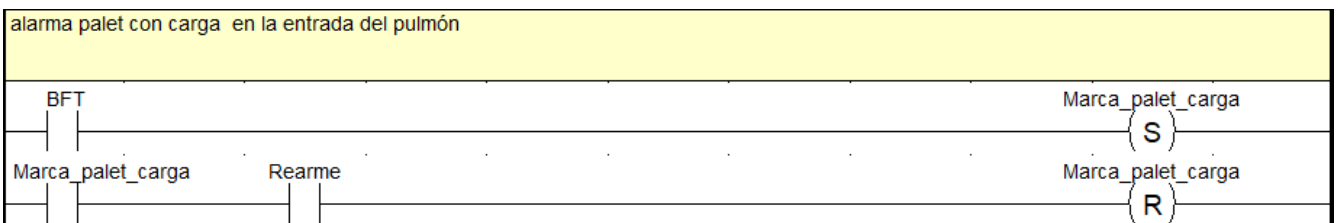
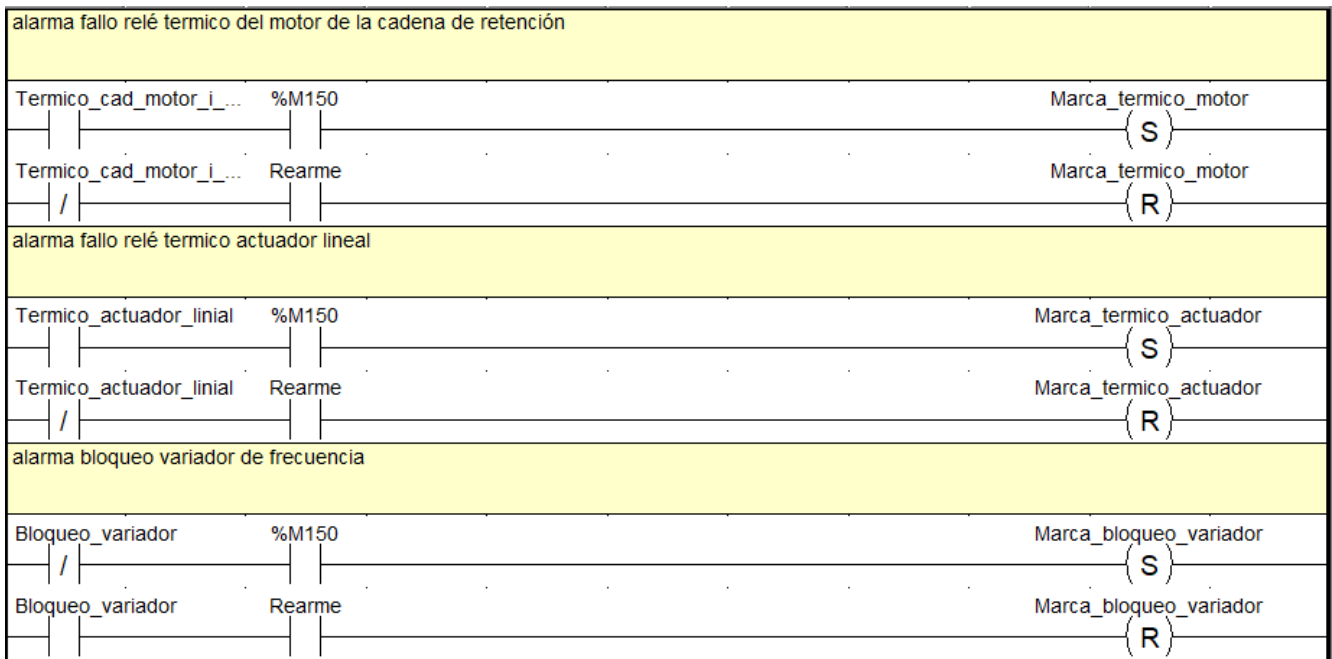
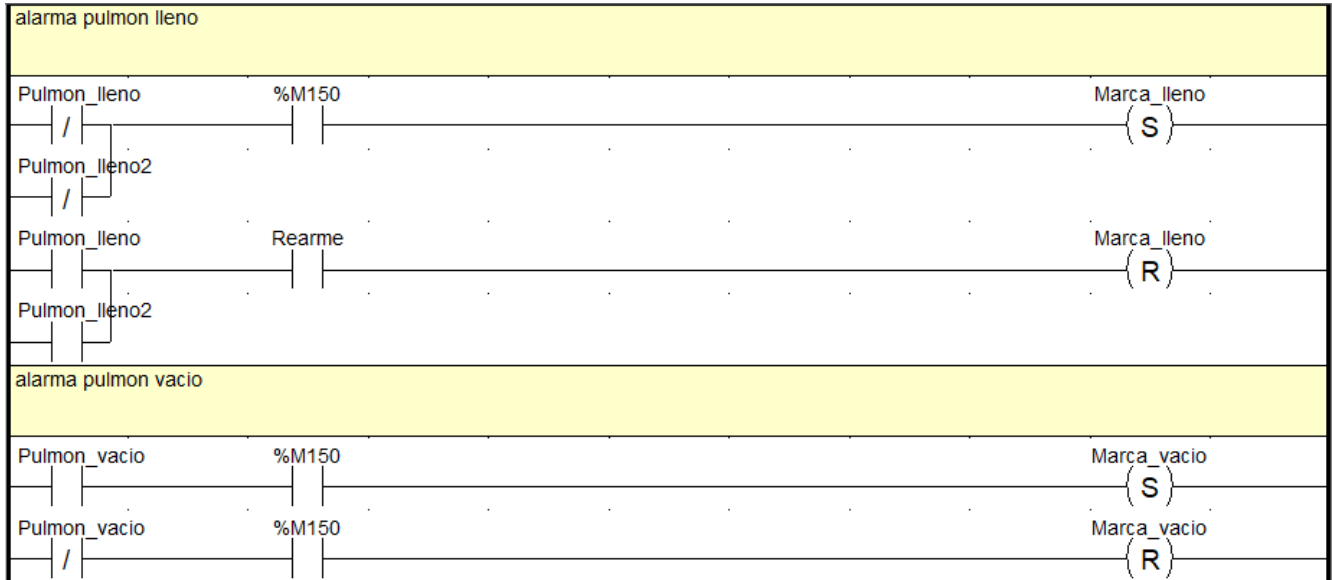

activar marca para ejecutar la intermitencia cuando haya alguna alarma activa

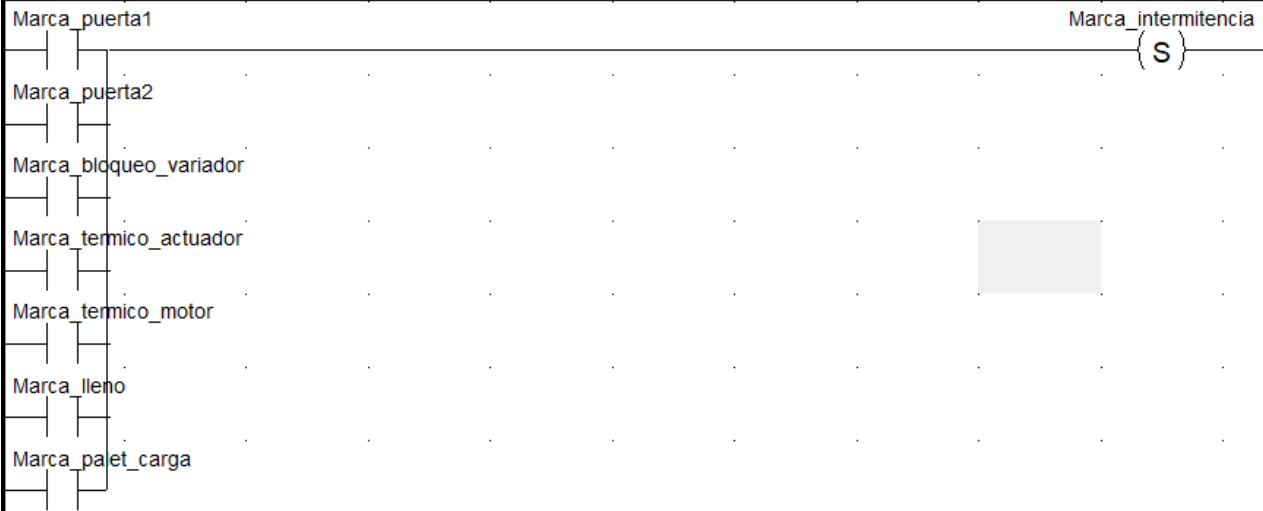

desactivar la marca de la intermitencia cuando no exista ninguna alarma activa

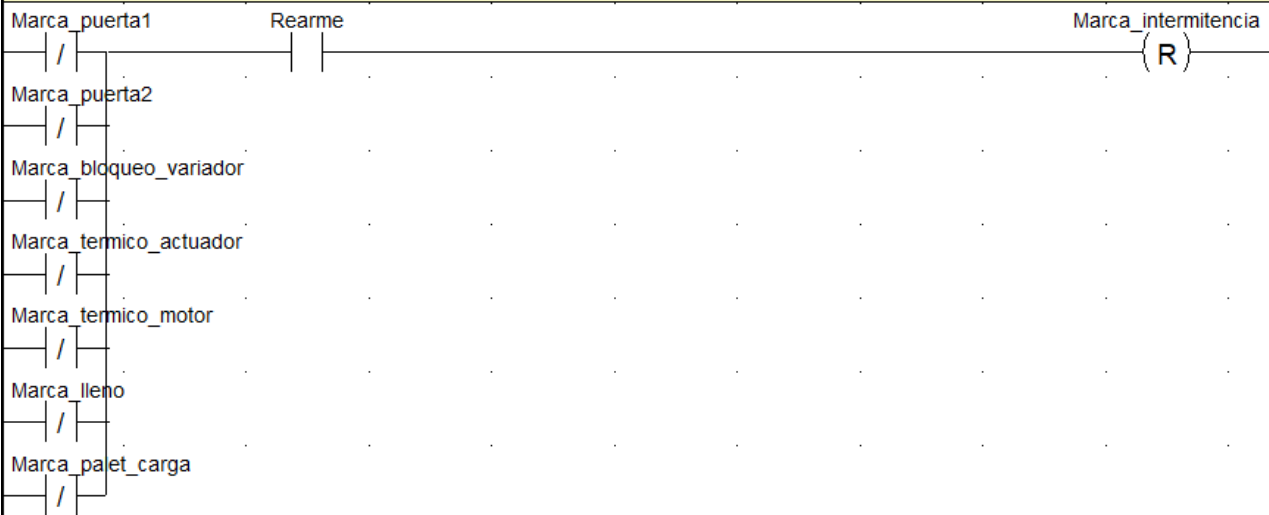

Intermitencia mediante dos temporizadores. Activación piloto rojo intermitente con cualquier alarma excepto emergencia y pulmón lleno (piloto rojo fijo)

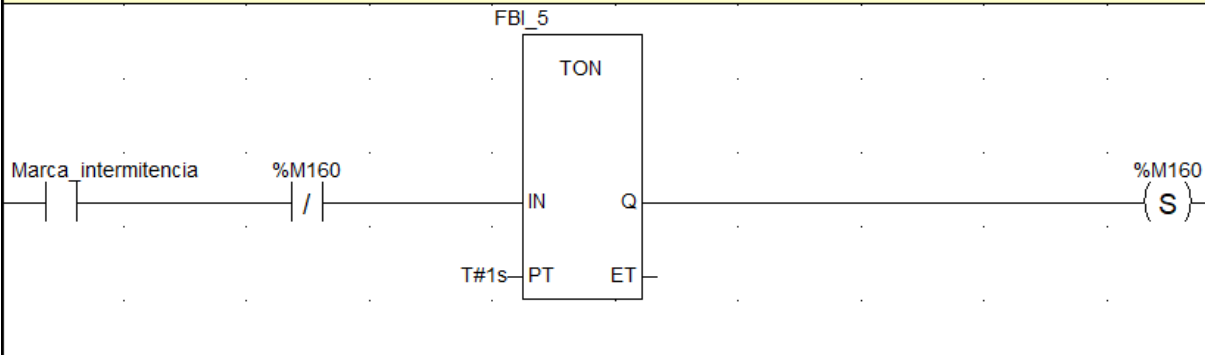

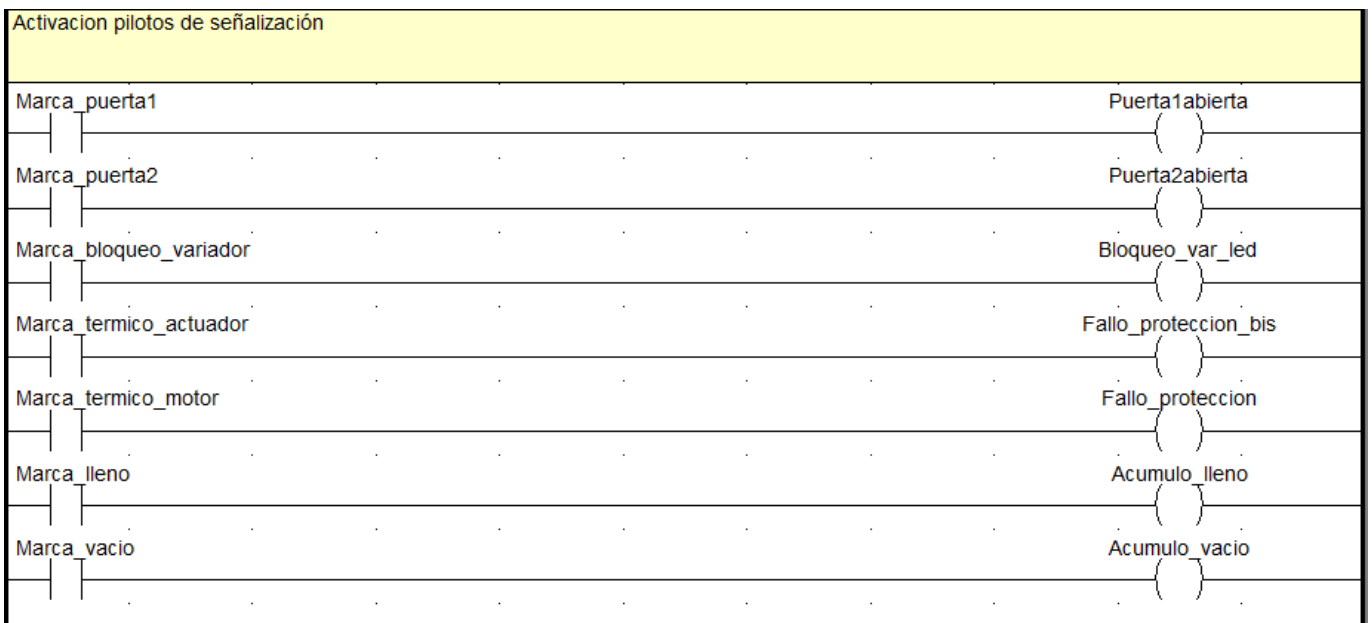
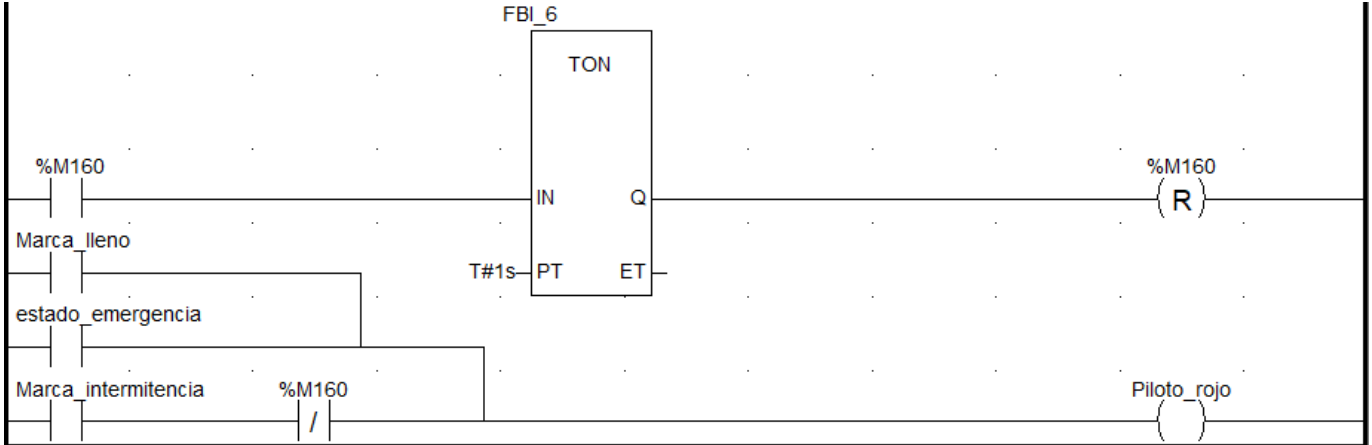

**Estados:**

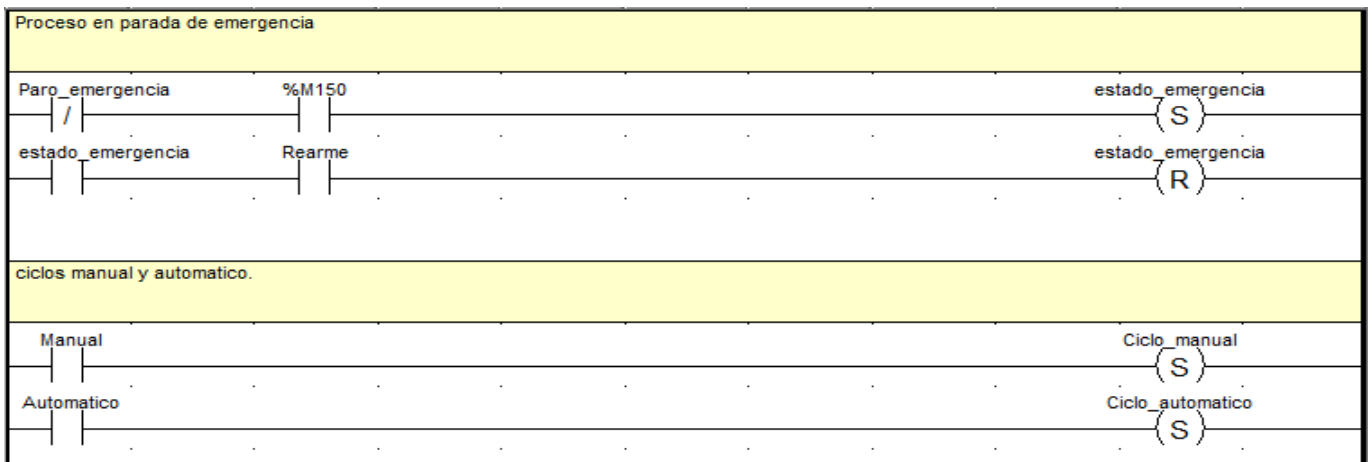

**Reposo:**

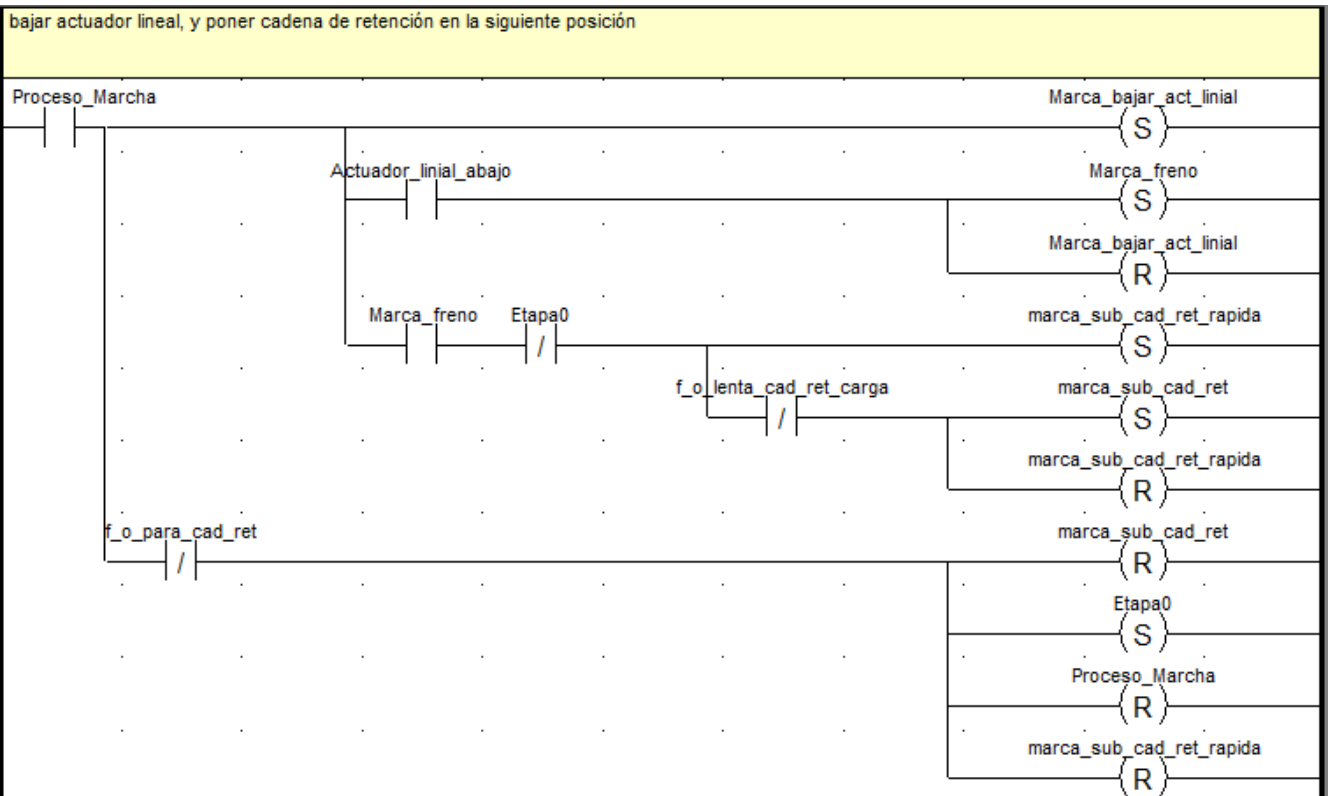
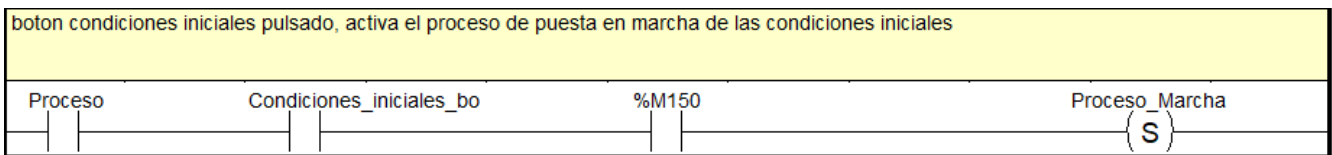
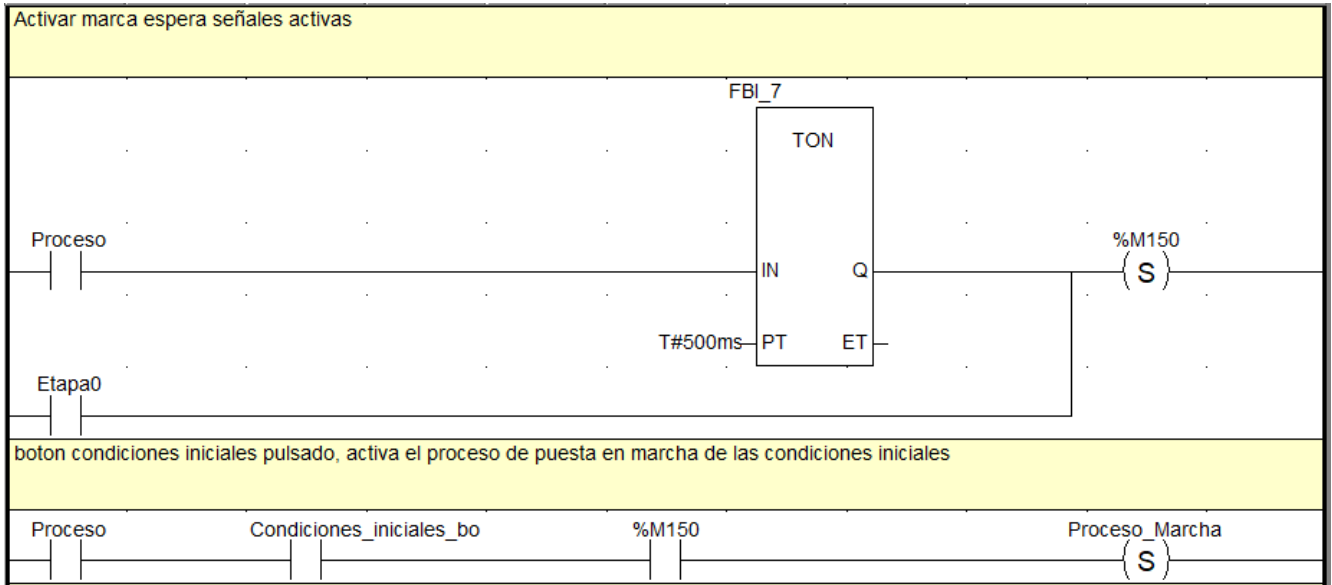

## Carga\_palet:

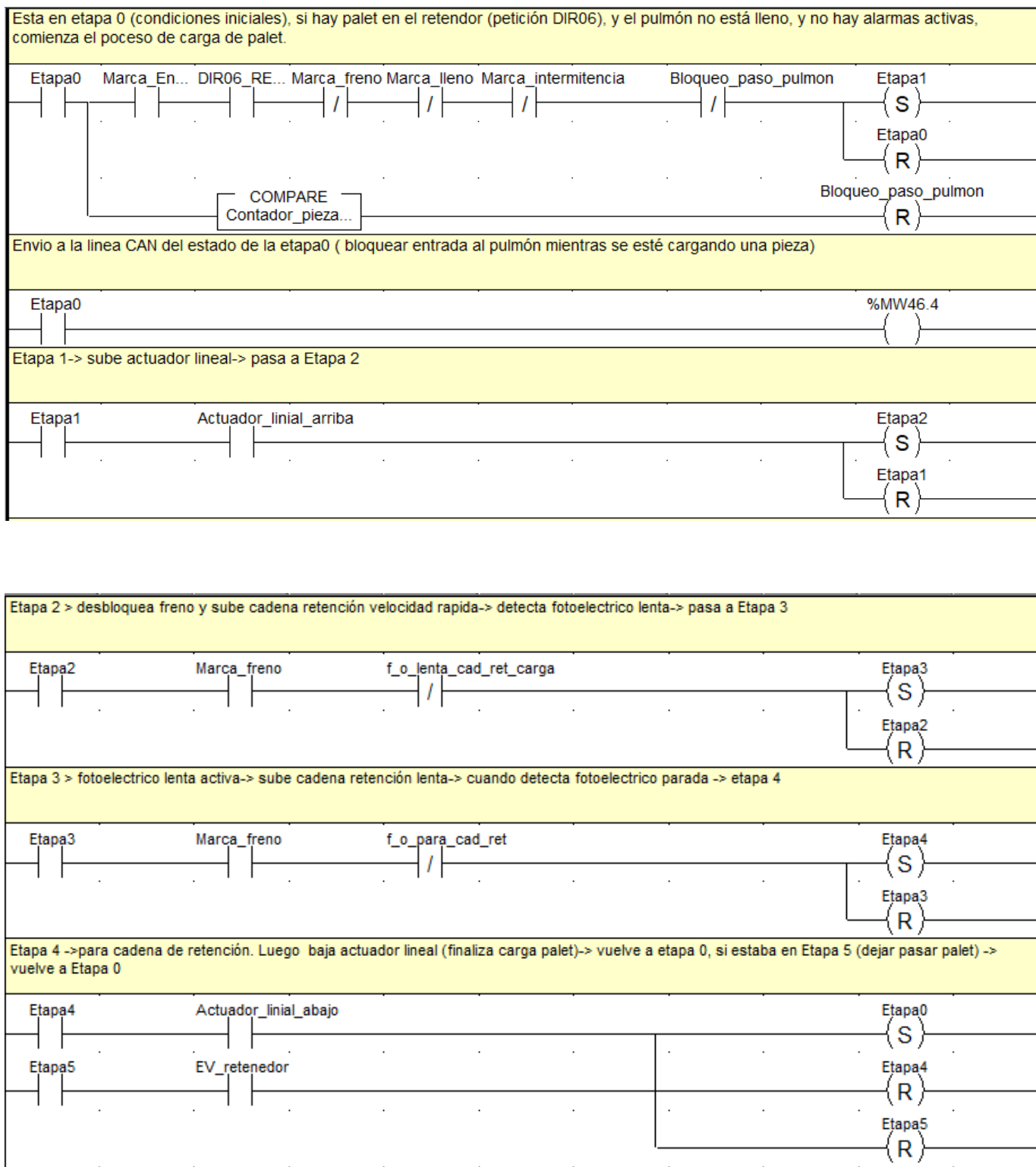

### Descarga\_palet:

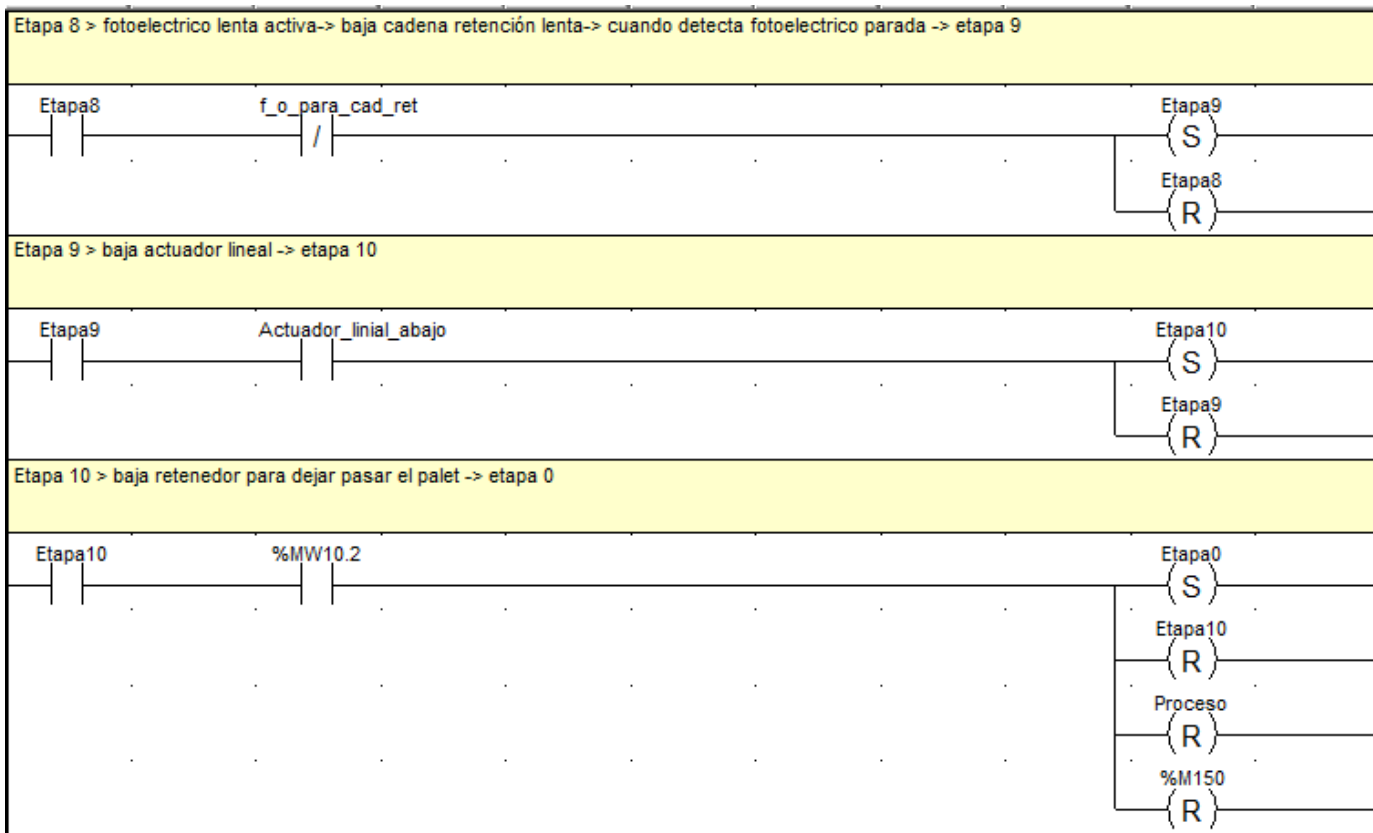
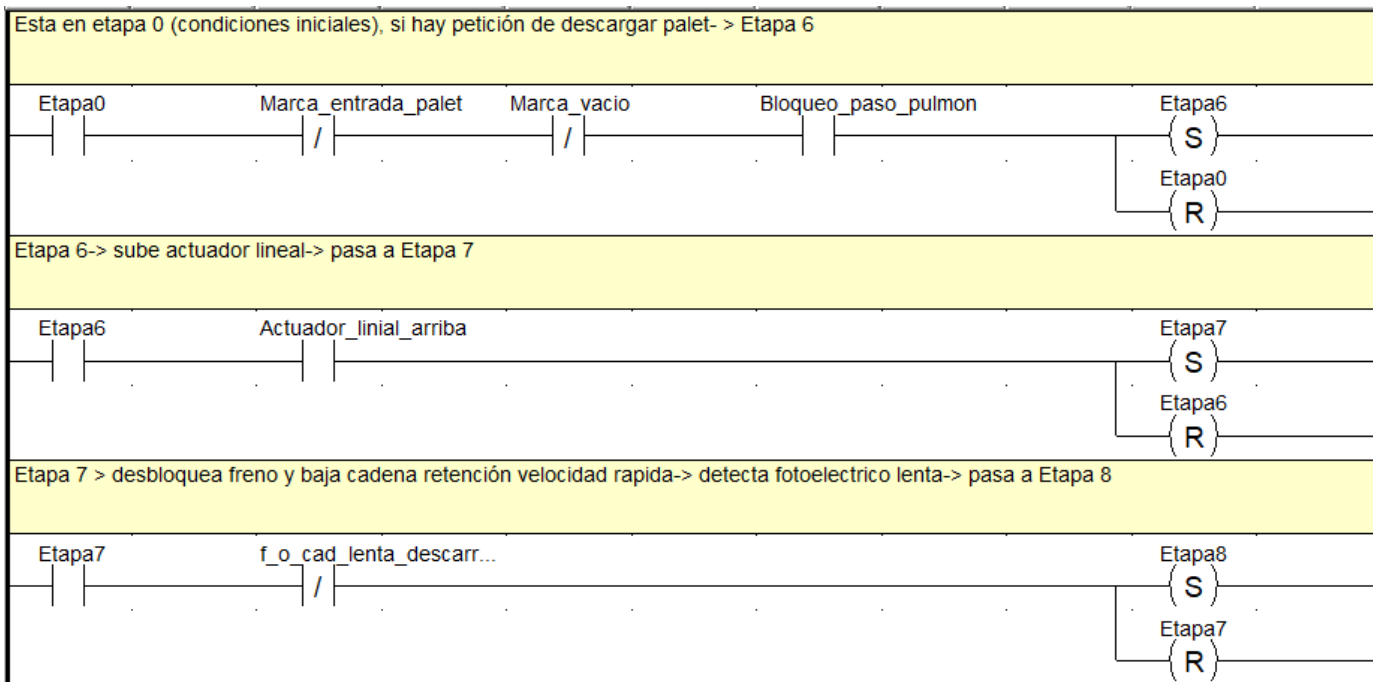

**Activacion\_salidas:**

