

## CHARACTERISTICS OF MICRO INCREMENTAL IN-PLANE BENDING OF SHEET METAL USING TILTABLE PUNCH

AHMAD AZRIE\* AND TAKASHI KUBOKI\*

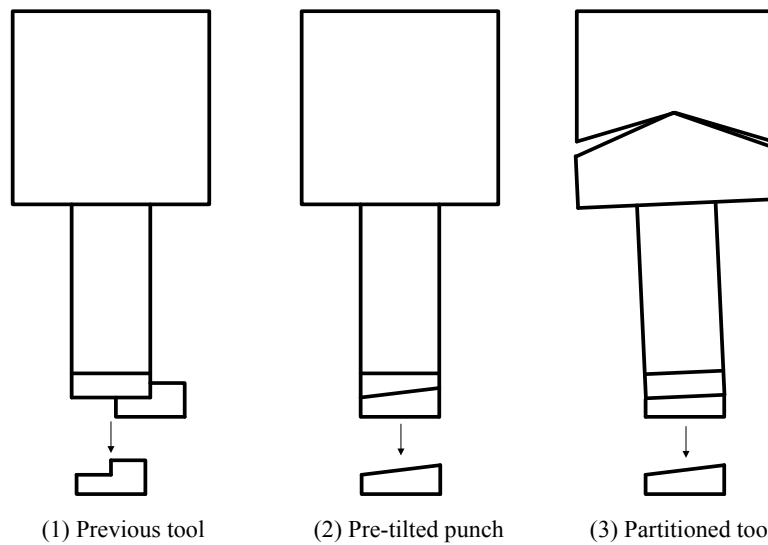
\* University of Electro-Communications (UEC)  
1-5-1 Chofugaoka, 182-8585 Tokyo, Japan  
e-mail: azrie@mt.mce.uec.ac.jp, kuboki@mce.uec.ac.jp

**Key words:** Incremental forming, Sheet metal, Bending, Tilttable punch, In-plane bending

**Abstract.** Incremental forming methods have gained interest in recent years as a forming technique for micro and fine components. This paper presents a newly developed incremental in-plane bending with tilttable punch for micro-metal sheets whose thickness is less than 1mm. The punch has two unique points. Firstly, it has a joint which enables the punch tilt freely according to the contact pressure. Secondly, the punch "sole" has a trapezoidal shape, where the toe is thin and the heel is wide. With increase of indentation, the toe bites deeper into metal than the heel resulting in the thickness distribution. As a result, the thin sheet metal is bent without any difficulty of punch positioning. Among the conditions of incremental bending, the effects of the toe angle of the punch sole during contact on the bending radius are examined by experiments, calculations and analysis. As a result, incremental forming with a tool with a toe angle of 30 degrees results in the largest sheet-metal curvature.

### 1 INTRODUCTION

Incremental forming methods have gained interest in recent years as a forming technique for micro and fine components. The formed components are expected to be used as parts and chassis of micro-devices for medical use or micro machines. Electrical and chemical methods, including semiconductor manufacturing technology, have been used as main techniques for micro-component fabrication. However, they have demerit in productivity as they take time for building up layer or etching matrix. Technology of plasticity like incremental forming methods would improve the productivity. In many cases of conventional incremental forming, the material is deformed by point contact between punch and material. If line contact is realized instead of point contact, it would enhance the productivity drastically.



**Fig. 1** Distribution of material thickness after forming in previous method and proposed method

Incremental in-plane bending with a pre-tilted punch tool has been proposed as a line contact bending method for thick sheet metal with thickness of 2mm[1]. In this incremental bending method, the sheet metal is beaten across the breadth direction so that the indentation depth changes from one side to the other proportionally. This distribution of metal thickness results in bending of the sheet metal due to the constancy of volume before and after forming. However, this method cannot be applied for thinner sheet metals due to the positioning of the punch tool.

In this paper, an incremental in-plane sheet metal bending method which utilizes a 2 segmented tilt-able punch tool with a trapezoidal contact point or “sole” is proposed. The combination of a trapezoidal sole and a tilt-able joint assists the generation of an even pressure distribution on the sheet metal. The effects of the toe angle of the punch tool on the bending radius as well as the pressure distribution on the sheet metal are examined by experiments and analysis.

## 2 EXPERIMENTAL PROCEDURE

Fig.1 illustrates the distribution of material thickness after forming in previous method and the proposed method. In the previous method, a rectangular soled punch tool was utilized. By adjusting the position of the punch tool across the width direction of the material, bending was made possible due to the difference of elongation as illustrated in Fig.1 (1). The distribution of thickness was improved by making the elongation difference proportional across the width direction by using a pre-tilted punch tool, as illustrated in Fig.1(2). However, positioning of the punch tool is difficult in the case of thinner materials. In this paper, to alleviate the difficulty of tool positioning, a partitioned tool with joint for tilting, as shown in Fig.1 (3), is proposed.

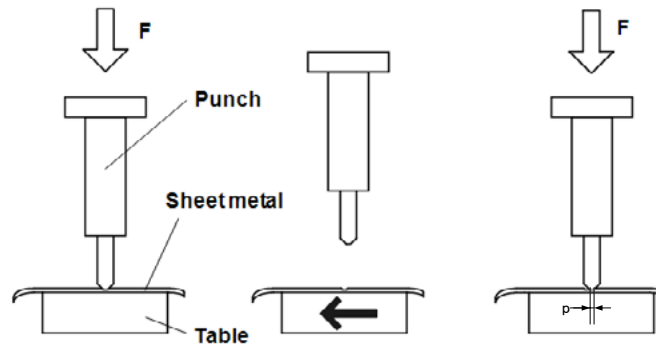


Fig. 2 Schematic of incremental forming for sheet metal

The schematic of incremental forming for sheet metal is illustrated in Fig.2. The material is placed on a horizontal XY axis work table and is indented with the punch tool. The material is then moved in the length direction of the sheet metal and indented again. The distance between indentations is referred to as the feed pitch,  $P$ . This process is repeated 20 times with a constant pitch for each condition.

## 2.1 Experimental equipment

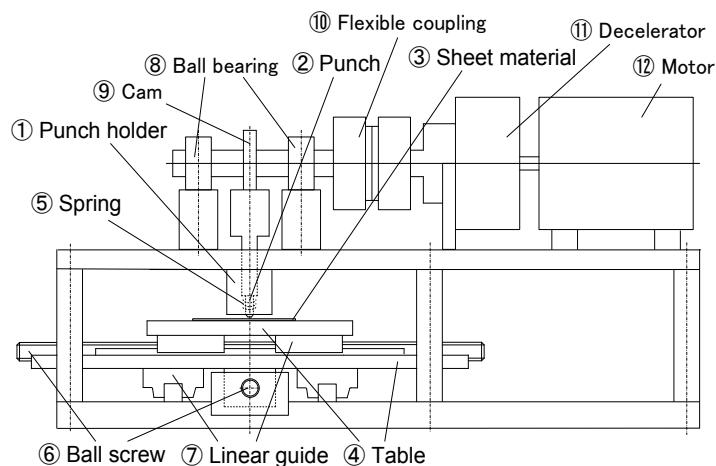


Fig. 3 Experimental equipment

The equipment used for the experiment is shown in Fig. 3. Vertical motion of the punch tool is realized utilizing a motor and decelerator and a shaft which is connected to a cam. This cam converts the rotation of the motor into a vertical motion of the punch with periodic intervals. The punch is held in place with a punch holder. After a downward motion, the punch returns to its original position utilizing a spring in the punch holder.

## 2.2 Test piece and punch tool

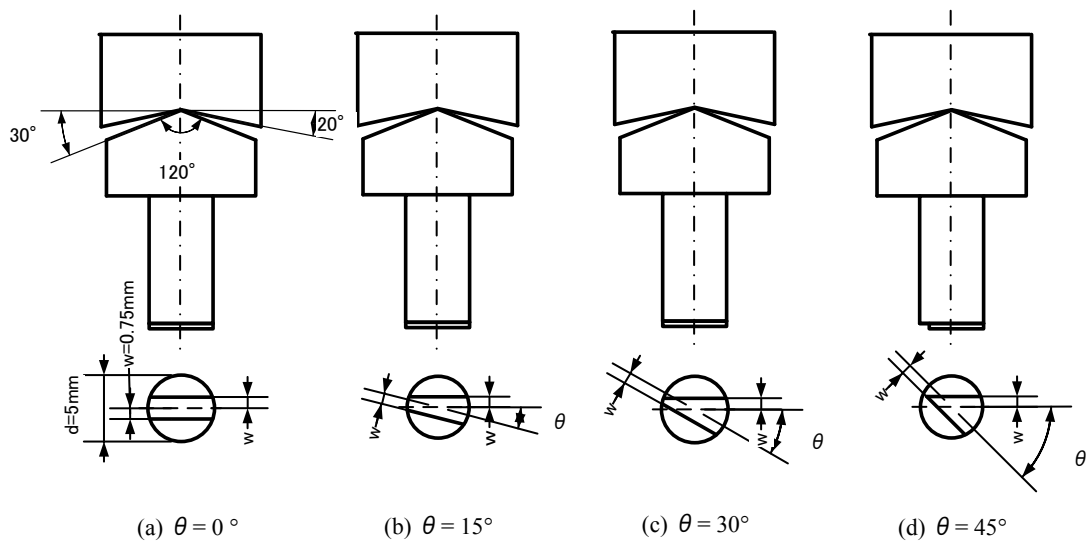
The dimension of the sheet metal is shown in Table 1. The material used for the sheet metal is aluminium A1050.

**Table 1:** Dimension of test piece

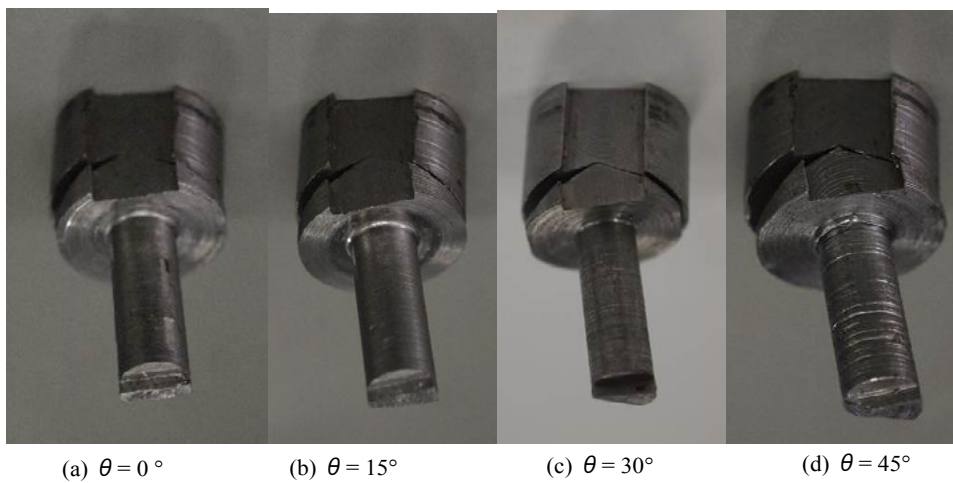
Dimension	Length $L$ /mm	200
	Width $B$ /mm	5.0
	Thickness $t_0$ /mm	0.5
Material	Aluminium A1050 (JIS)	

**Table 2:** Dimension of punch tool

Punch tool	Outside diameter $d$ /mm	5.0
	Width from center line $w$ /mm	0.75
	Toe angle $\theta$ / °	0, 15, 30, 45
Material	Medium carbon steel S45C (JIS)	



**Fig. 4** Geometry of punch tool



**Fig. 5** Appearance of punch tool

The geometry and physical appearance of the punch tools are illustrated in Fig. 4 and Fig. 5, respectively. The tool is constructed from medium carbon steel S45C (JIS), using a lathe and a milling machine. The sector of the contact surface is machined so that the width of one half of the contact surface might be  $w=0.75\text{mm}$ , as shown in Fig. 4. The tool is then rotated with angles of  $\theta = 0, 15, 30$  and  $45$  degrees, and then machined again so that the other half of the contact surface is  $0.75\text{mm}$  to form a toe angle with a trapezoidal shape. The measurements of the sheet metal are shown in Table 2.

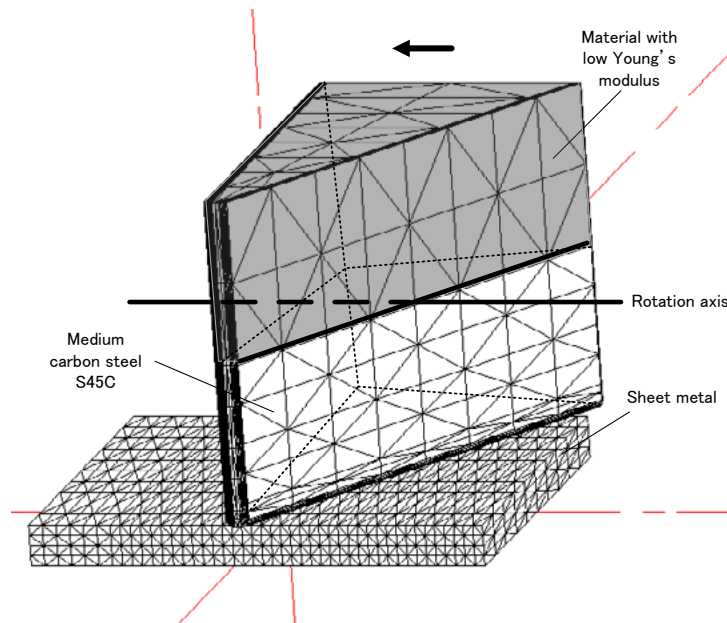
### 2.3 Experimental conditions

**Table 3:** Experimental conditions

Set Indentation $\delta_s$ /mm	0.2
Pitch $P$ /mm	0.25, 0.5, 0.75, 1.0, 1.25

The experimental conditions are shown in Table 3. The punch tools with toe angles  $\theta = 0, 15, 30$  and  $45$  degrees are used with a set indentation  $\delta_s$  of  $0.2\text{mm}$ . The set indentation is controlled by using  $0.1\text{mm}$  spacers inserted at the base of the punch tool. The experiments are conducted with pitches,  $P$  from  $0.25\text{mm}$  to  $1.25\text{mm}$ , which totals up to 20 conditions.

### 2.4 FEM Model

**Fig.6** Model of punch tool and sheet metal

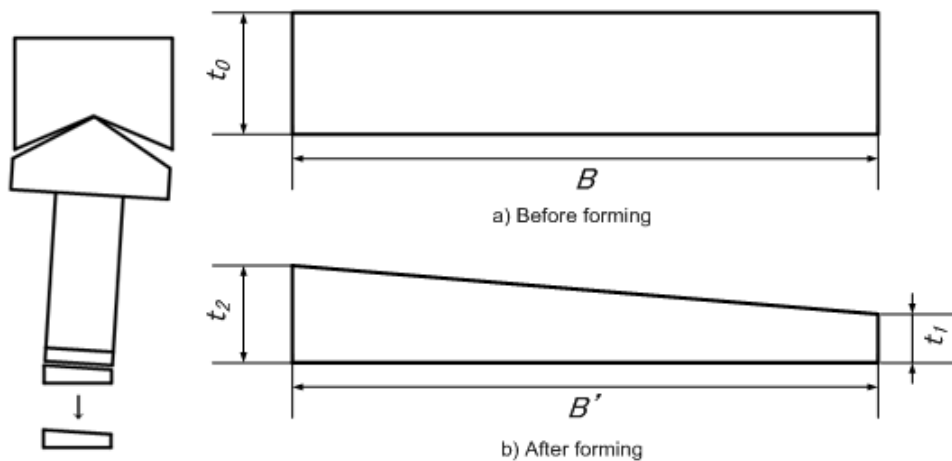
Electric-plastic analysis was conducted using the commercial code ELFEN developed by Rockfield Software Ltd., Swansea to examine the contact pressure distribution on the sheet metal. The model of the punch tool and sheet metal is illustrated in Fig. 6. While the punch tool has a free-tilting joint in the experiment, the top half of the punch tool model is constructed from elastic material with low Young's modulus,  $E$  of 100MPa. The bottom half of the punch model is medium carbon steel S45C, and a constraint is placed in between the two halves as the rotation axis, so that the punch tilts during contact with the sheet metal. The conditions of the FE analysis are shown in Table 4.

**Table 4:** Conditions of FEM analysis

Toe angle $\theta$ / degrees		30
Set indentation, $\delta s$ / mm		0.1
Pitch, P /mm		0.25
Friction coefficient $\mu$		0.25
Mesh division of material	Thickness	No. of divisions = 4
	Width	No. of divisions = 10
	Length	No. of divisions = 25
No. of beats		5
Analysis scheme		3D implicit incremental
Element type		Solid

### 3 EVALUATION AND RESULTS

#### 3.1 Evaluation of experimental results



**Fig. 10** Distribution of material thickness after forming with proposed punch tool

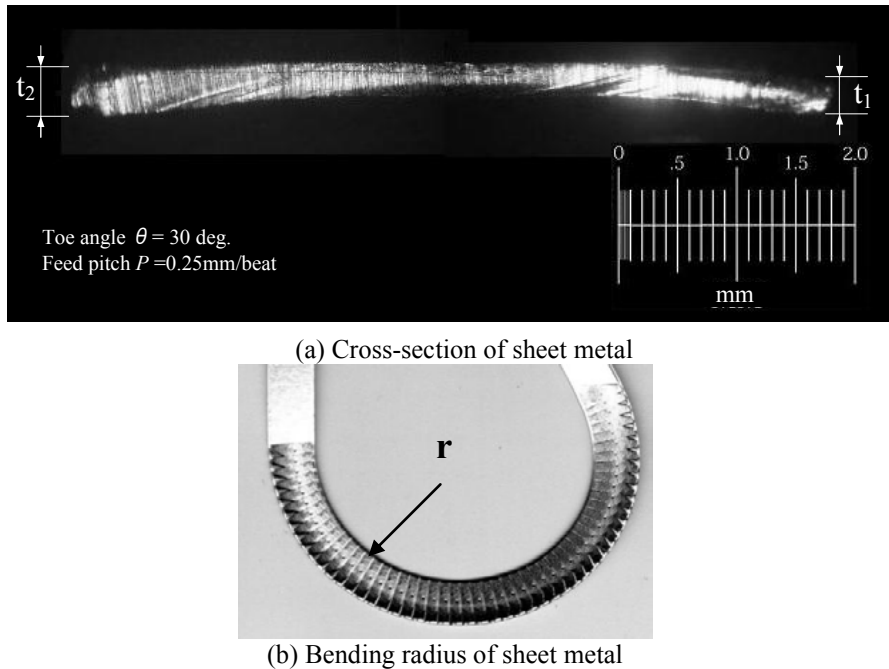
Fig. 10 shows the distribution of material thickness after forming with the proposed tool. The thickness of the material before forming is referred to as  $t_0$ . After forming, the thinnest

part of the material becomes the extrados with thickness  $t_1$ , and the thickest part of the material becomes the extrados with thickness  $t_2$ . The thicknesses are determined under a microscope with a digital scale before and after the experiments.

From the previous paper[1], it is understood that there is a negligible change of width before and after forming of the material. Therefore, the width of the sheet metal before and after forming is considered to be constant, is  $B'=B$ . Due to volume constancy, the curvature,  $R^{-1}$  of the bending arc with thickness  $t_1$  can be determined by the following equation.

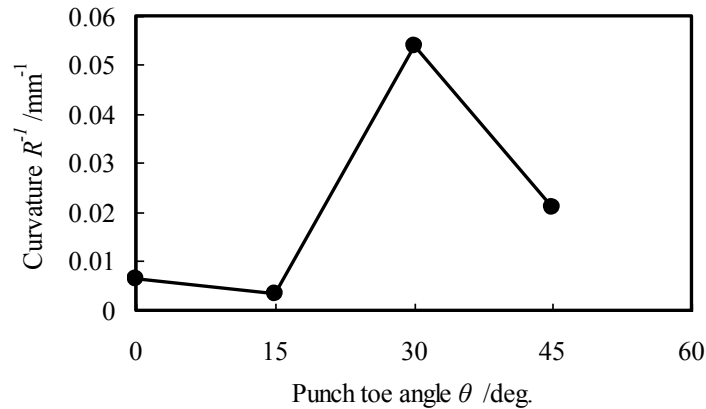
$$\frac{1}{R} = \frac{4Bt_0 - 2B'(t_1 + t_2)}{B'^2 (t_1 + t_2)} \quad (1)$$

### 3.2 Experimental results



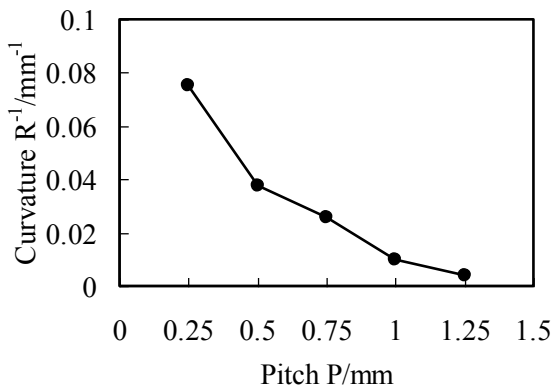
**Fig. 7** Cross-section and bending radius of sheet metal after forming

Fig. 7 illustrates the bending radius and the cross-section of the sheet metal after forming for toe angle  $\theta = 30$  degrees and feed pitch,  $P = 0.25$ mm per beat. The bending radiuses of the sheet metals are investigated using image processor software. Results for the experiments are shown in Fig. 8 and Fig. 9.

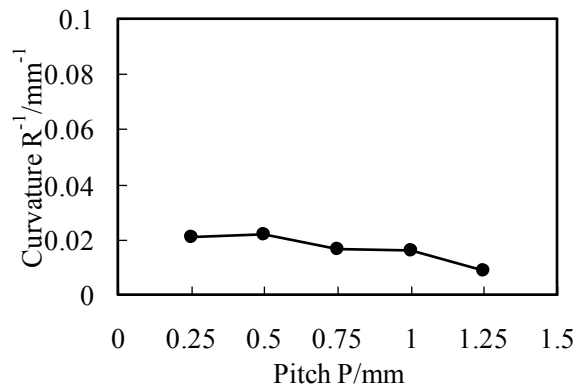


**Fig. 8** Relationship between toe angle and curvature (Set indentation,  $\delta s = 0.2\text{mm}$ )

The relationship between the toe angle and curvature is shown in Fig. 8. The curvature of the sheet metal has the smallest value with toe angles  $\theta = 0$  and 15 degrees, and drastically increases when the toe angle is 30 degrees. However, the curvature decreases again when the toe angle is 45 degrees.



(a) Toe angle  $\theta = 30$  deg



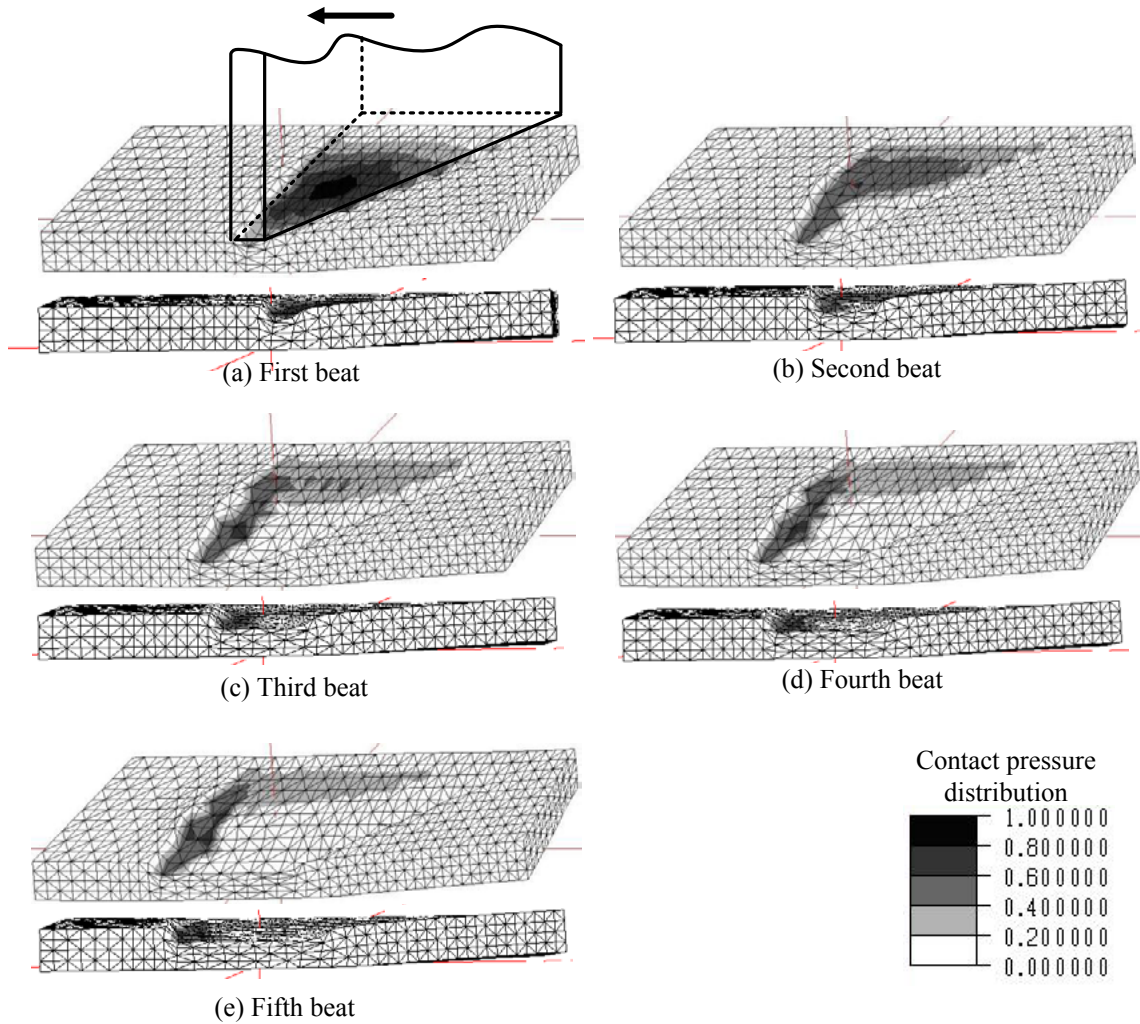
(b) Toe angle  $\theta = 45$  deg.

**Fig. 9** Relationship between pitch and curvature (Set indentation,  $\delta s = 0.2\text{mm}$ )

Fig. 9 illustrates the relationship between feed pitch and curvature of the sheet metal. The punch tool with toe angle of 30 degrees generates sheet metal with larger curvature than using a punch tool with an angle of 45 degrees. It is also noted that in the case of punch toe angle of 45 degrees, splitting occurred at the extrados of the sheet metal when the set indentation is 0.5mm.



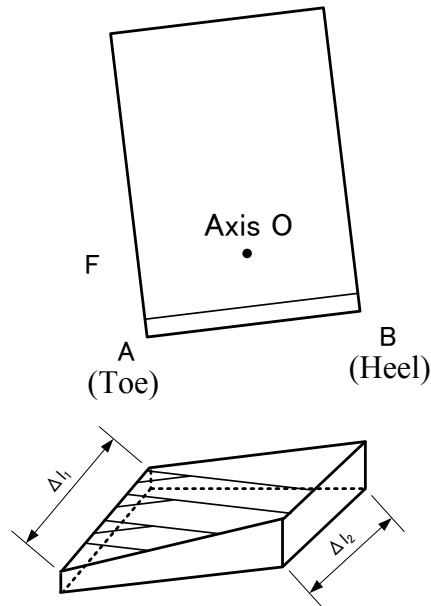
### 3.3 FE analysis results



**Fig. 10** Pressure on material (Set indentation,  $\delta s=0.1\text{mm}$ )

Fig. 10 shows the pressure distribution by the punch tool with toe angle  $\theta = 30$  degrees with set indentation  $\delta s=0.1\text{mm}$ . For the first beat, the distribution of contact pressure is spread across the contact surface of the sheet metal, with most stress focused on the center surface. After the first beat, the deforming stress gradually is distributed most at the extrados and least at the intrados of the material. The stability of the contact pressure is reached at the third beat.

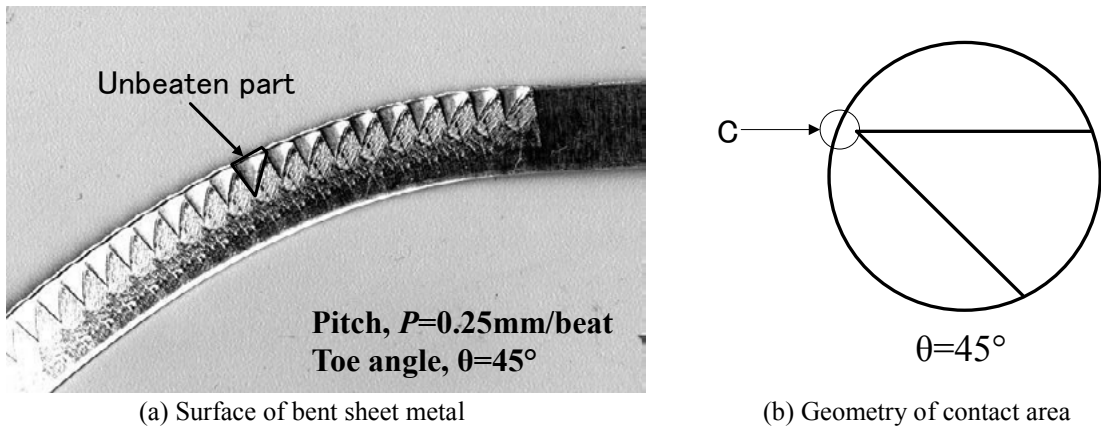
#### 4 DISCUSSION



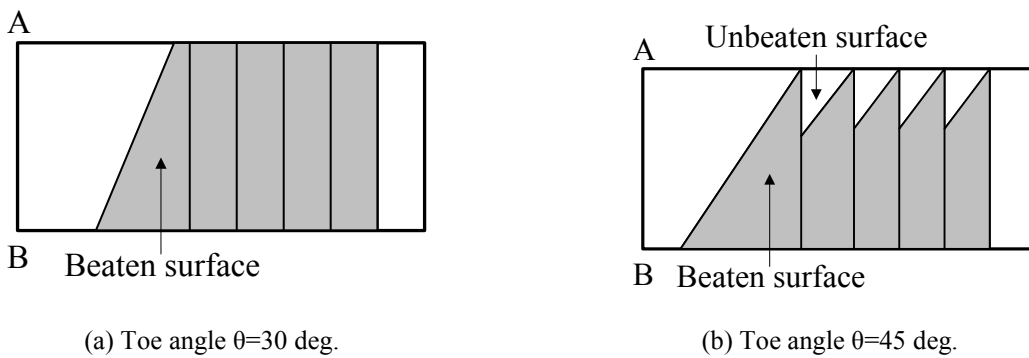
**Fig. 11** Bending mechanism of the sheet metal using the proposed punch tool

Fig. 11 illustrates the bending mechanism of the sheet metal using the proposed punch tool. From the experiments and analysis, it is understood that when the sole of the punch tool makes contact with the sheet metal surface, the punch tool tilts centred at point O. The punch tool bites deeper at the toe of the trapezoidal contact surface, and the indentation is less at the heel. A deeper indentation at the toe results in a larger deformation along the length of the material compared to the heel. Ultimately, the difference of indentation between the intrados and extrados results in in-plane bending of the material.

It is also understood that with a freely tilting jointed punch tool, there is an even indentation distribution across the breadth of the material due to the contact pressure of the punch tool. The toe of the contact surface has a bigger contact pressure, while the heel has a smaller contact pressure on the material. This occurrence results in the punch tilting on contact with the sheet metal because of the equilibrium of moments between the toe and heel. Utilizing the proposed tilting punch tool, there is no difficulty positioning the punch tool even when bending thin sheet metal.



**Fig. 12** Surface of bent sheet metal and geometry of contact are of punch tool



**Fig.13** Illustration of beaten and unbeaten surface using toe angle  $\theta = 30$  and  $45$  deg

For a punch tool with toe angle of 45 degrees, the overall curvature of the sheet metal is less than that of using a punch tool with toe angle  $\theta = 30$  degrees. This is caused by a larger unbeaten surface using a punch with toe angle  $\theta = 45$  degrees compared to 30 degrees, when the pitch conditions are the same. Fig. 12 illustrates (a) the surface of the bent sheet metal, and (b) the geometry of the contact area of the punch tool with toe angle  $\theta = 45$  degrees. Figs .13(a) and 13(b) show the beaten surface and unbeaten surface of punch tools of toe angle  $\theta = 30$  and 45 degrees, respectively. A gap area C illustrated in Fig. 12(b) causes an unbeaten surface to be formed on the material during forming. It is understood that a larger unbeaten area total results in a smaller total of deformation after incremental indentation. The lengthwise deformation of the extrados with a large unbeaten area causes a smaller deformation difference between the extrados and the intrados. This occurrence causes a larger radius of the material, hence a smaller bending curvature.

## 5 CONCLUSIONS

As a preliminary experiment showed that the proposed punch tool with a free-tilting joint, with a toe angle of 30 degrees was effective in bending a thin sheet metal with the thickness of 0.5mm. The deformation and contact pressure distribution were investigated with experiments and numerical analysis, and the optimum conditions of the punch toe angle are around 30 degrees in all variations of set indentations. It is also understood that utilizing a

punch with a free tilting joint combined with a trapezoidal contact surface, a proportional distribution of indentation occurs along the breadth of the beaten material because of the equilibrium of moments. However, when the punch toe angle is 45 degrees, two forming defects occur when bending. First, splitting occurs at the extrados of the sheet metal at higher set indentations. Second, a gap at the contact surface of the punch with toe angle of 45 degrees causes a larger unbeaten surface which decreases the curvature of the bent sheet metal.

## REFERENCES

- [1] Y. Jin, T. Kuboki, M. Murata, Influence of strip materials on behavior of incremental in-plane bending, *J. Mater. Process. Technol.*, 162-163 (2005), pp. 190-195
- [2] Z. Marciniak, J.L. Duncan, S.J. Hu : *Mechanics of Sheet Metal Forming*, Butterworth-Heinemann Publications (2002), pp. 82-83
- [3] Y. Saotome, State of the Art in Micro Forming and View in the Future, *J. Mater. Process. Technol.* 49-570, Corona Publications (2008), pp. 4-7
- [4] S. Hama, T. Kuboki, M. Murata, Incremental in-plane bending of thin sheet metals, *Uni. of Electro-Communications*, (2012), pp. 52-53
- [5] S. Inaba, T. Kuboki, M. Murata, In-plane bending by incremental beating, *Univ. of Electro-Communications*, (2011), pp. 19-22, 31