

Modelling and Simulation of the Primary Power Distribution of a Lunar Habitat

Mario F. Palos*, Aidan Cowley**, Ricard González-Cinca*[†]

**Universitat Politècnica de Catalunya - BarcelonaTech
Carrer d'Esteve Terradas 7, 08860 Castelldefels, Barcelona*

***ESA/EAC (European Astronaut Centre)
Linder Höhe, 51147 Cologne*

[†]Corresponding author: ricard.gonzalez@upc.edu

Abstract

A MATLAB/Simulink model of the Primary Power Distribution System of a lunar habitat is presented. The model can be adapted to multiple scenarios, and is able to interface with computer models of other habitat subsystems. A constant supply of power is considered regardless of the source and the time of the day, regulating the bus voltage when required. The electrical system of the International Space Station is used for reference and validation. The model has been tested in two scenarios representing two locations on the surface of the Moon.

1. Introduction

The Electrical Power System (EPS) is a key element of any space platform due to its critical duties. In particular, it becomes specially important in spaceships or extraterrestrial habitats in which the safety of a human crew depends on it. The EPS must provide the right amount of power to the spacecraft, manage efficiently any excess or lack of energy, provide a ground reference to the onboard electronics, and include redundancy and several security measures in order to survive malfunctions or damage caused by external forces.

We present a MATLAB/Simulink computer model of an EPS for a lunar habitat. Initially, a model for the EPS of the International Space Station (ISS) was designed. Most of the design choices made for the ISS electrical systems are appropriate for a solar-powered lunar habitat as well. The simulation of the existing system for the ISS, with a large amount of available data, allowed us the validation of the model. Finally, the model was adapted to the particular characteristics of a Moon habitat and simulations for different scenarios were carried out.

Section 2 contains the description of the ISS power system. The numerical model of the ISS power system and simulation results are presented in Section 3. Section 4 contains the description of the lunar habitat power system and simulation results at different habitat locations. Conclusions are presented in 5.

2. The ISS's power system

The EPS of the ISS is divided in two parts: the Primary Power System (PPS) and the the Secondary Power System (SPS). The PPS coarsely regulates the voltage coming from the solar panels down to 133-177 V DC.¹¹ Downstream, right before the payloads, the SPS tunes the voltage to 123-126 V DC.

We have considered exclusively the PPS given the SPS operation is simple and well known. Fig. 1 shows a diagram of the PPS in the ISS. The PPS is divided into eight equal and independent power channels. In case of malfunction of a channel the orphaned loads can be routed to a different one. Each channel includes a Solar Array Wing (SAW), a Sequential Shunt Unit (SSU), a DC Switching Unit (DCSU), and three Battery Charge-Discharge Units (BCDU) controlling three battery sets. The eight channels are connected in pairs to four Main Bus Switching Units (MBSU) that route power to DC to DC Converter Units (DDCU), which are in charge of conditioning the power and transmitting it to the loads.¹¹ The photogenerated energy is funneled through the SSU, which allows the required amount of energy to flow downstream, while the excess of energy is radiated back to space. The electricity that is allowed into the station feeds the batteries provided that there is an energy surplus and that they are not full, and gives energy to the electrical loads.

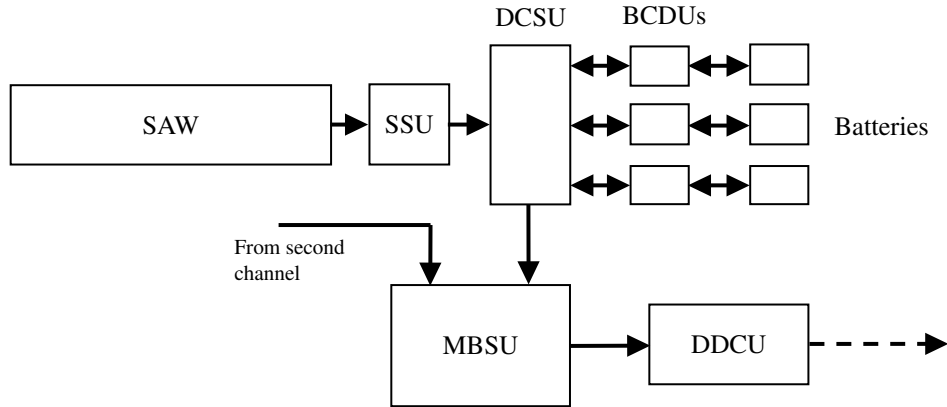

Figure 1: Diagram of the Primary Power System of the ISS.

2.1 Solar panels

The United States Orbital Segment (USOS) of the ISS is powered by eight Solar Array Wings (SAW), each of them consisting in two layers of thin photovoltaic (PV) cells attached to a mast for deployment and retraction. Each layer consists of 16400 individual silicon PV cells grouped in 41 parallel strings of 400 cells in series, with an extra empty row added at the base given this zone is easily eclipsed by the station truss.¹¹ This hybrid setup increases both the voltage and current output of the individual cells. The performance of the cells (Spectrolab™ PV K6700B) is low compared to modern standards. The USOS panels working at full power can provide between 84 and 120 kW. The high surface area of the panels makes them also useful as radiators for the excess of energy that the station cannot store or use.

2.2 Sequential Shunt Unit

The SSU is the component of the PPS in charge of the coarse regulation of voltage by shunting unneeded energy out of the station. It is also the most complex part of the simulator.

An illuminated solar cell produces a photocurrent that generates an amount of power that depends on the load connected to the panel, obeying $P = I^2R$. The ISS receives more energy than it needs during daytime. If the power required by the station at a given time was extracted from the photocurrent generated at that time, the voltage would be $V = P/I$, which means that under full illumination the voltage would probably drop to unusable levels. The extra energy can be stored in batteries until they are full. However, beyond this point the only way to control the voltage under full illumination is to lower the current in the system by energy rejection. The excess of energy is not an oversight. On the contrary, it was considered in the system design in order to account for the unavoidable degradation of solar cells in space and the ever-expanding power needs of a modular space station.

A solar panel working on Earth would be constantly kept at the Maximum Power Point (MPP), the combination of V and I that outputs the highest power for a given set of illumination and temperature conditions. Given the excess of energy in orbit, there is no need for an active MPP tracking, but the voltage setpoint is a fixed approximation of what it would be, typically 160 VDC. This value is adjusted as the solar arrays age.¹¹

The most common topology for shunt regulators in space is the Sequential Switching Shunt Regulator (S3R),⁹ invented in 1977 by D. O'Sullivan and A. Weinberg in ESTEC. The characteristics of the PPS in the ISS and the S3R are similar. In this bus topology, the parallel strings of solar cells can be individually connected to the bus or shunted to ground, roughly adapting the photocurrent flowing into the bus to the needs of the station. The voltage on the main bus, V_{bus} , gives information about the required number of strings. V_{bus} rising over the setpoint is a symptom of a defect of photocurrent, which can be solved by connecting additional solar cells strings to the main bus, and viceversa. If V_{bus} was used as a control signal the system would jump back and forth continuously. Instead, the voltage is fed into a Main Error Amplifier (MEA), which works as an integrator that creates the control signal V_{error} (equation 1) that the SSU uses to decide the appropriate reaction:

$$V_{error} = \int_0^t (V_{bus} - V_{setpoint}) dt. \quad (1)$$

V_{error} increases when I_{solar} is not high enough, and viceversa, while the controller function is to keep it at

a constant value. As V_{error} changes, it sweeps the possible domains of operation: Discharge, Charge, and Shunt, depending on whether there is an excess of energy in the system or not, and whether this energy will be stored in the batteries or radiated into space. During the night the system is in the Battery Discharger domain, where power is extracted from the batteries and converted to the required voltage. When the Sun rises, the panels add photocurrent to the current coming from the batteries, lowering the voltage under the setpoint and initiating a reaction. The system is then in the Battery Charger domain, feeding all the extra energy into the batteries. The system is working at optimal voltage with all SAW strings connecte, until the batteries are full. From this point on V_{error} starts decreasing and the system goes into the Shunt domain, where solar cell strings are disconnected sequentially from the bus with the aim at making V_{error} constant. As the following sunset approaches, V_{error} increases, and the system passes straight from the Shunt to the Battery Discharger domain. The Battery Charger domain is skipped since the batteries are full after hours of illumination.

In general, the required current will not correspond exactly to a whole number of strings. The voltage will usually be either slightly higher or slightly lower, and will change between both. In order to avoid constant switching of the panels, the S3R operates as a bang-bang (or hysteretic) controller.² In practise this means that the error thresholds that activate extra strings are displaced with respect to the thresholds that deactivate them.

2.3 Switching and Converting units

The primary function of the DCSU is to transfer the photogenerated energy to the battery packs, the loads, or back to the SAW for dissipation. The loads always have priority over the batteries.

The MBSU route power to their assigned loads, and can temporarily divert some power from another power channel in case of malfunction. For the sake of simplicity, only one of the eight power channels has been modelled here.

The DDCU connect the primary and secondary power systems. DDCU conditions the voltage to a stable value of $155 \pm 22V$. It is assumed to be a buck converter, because except for catastrophic failure the voltage in the SPS is always lower than in the PPS.

2.4 Load

The power demands of the ISS are between 75 and 90 kW. The exact amount depends on a number of factors like the time of the day, the number of connected subsystems, and the number of visiting spacecraft. There is no direct relationship between the power consumption cycles and the illumination cycle.

The load data used here comes from the Columbus module training mockup at the European Astronaut Centre, whose power consumption oscillates between 2.2 and 3.2 kW. Although this data does not correspond exactly to the power consumption of the Columbus module in orbit, it is of the same order of magnitude.

2.5 Battery Charge-Discharge Unit and Battery Packs

The BCDU controls the power flow in and out of the batteries depending on the power needs and the state of charge (SOC) of the batteries. The charging current is caped if it is over the battery specifications, and the discharging current is adjusted according to the power required by the station.¹¹

The ISS is currently in the process of replacing the NiH₂ batteries by Li-Ion batteries to obtain the same capacity with half the number of Orbital Replacement Units.⁵ Even though there is more available data on NiH₂ batteries, in our simulator we consider the new Li-Ion batteries. The Li-Ion batteries are located on the main truss of the station and contain 30 cells in series. In the ISS EPS convention, charging current is considered negative.⁴ Li-Ion batteries are always charged using a constant current (CC) - constant voltage (CV) strategy. First the battery is charged at a predefined constant current until a certain voltage is reached. If the battery is composed of several cells, it may be necessary to balance the charge between them. Once they are stable, batteries are charged at constant voltage until they are full.

3. ISS power system model and simulations

3.1 Numerical model

Fig. 2 shows the numerical model of the ISS power system. It consists of a simplification of the actual PPS, its main changes being in the SAW, SSU, and BCDU.

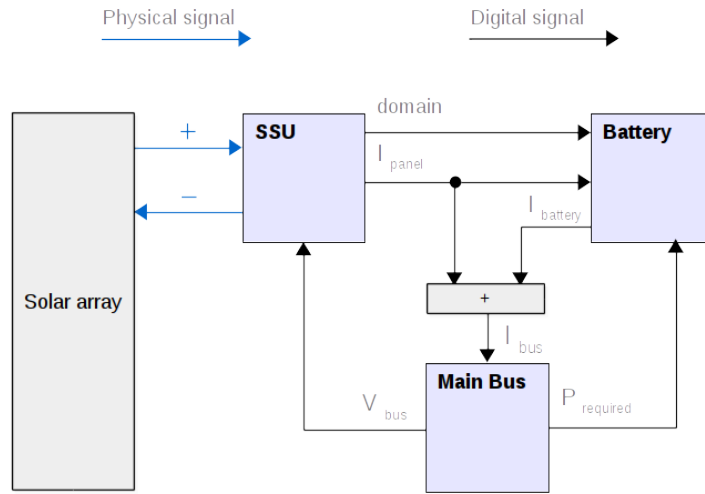

Figure 2: Diagram of the Simulink model

The solar cells are modelled using Simscape Electronics Solar Cell blocks, configured to represent 400 cells in series. They function as constant current sources whose output depends on illumination. Including the 41 solar strings with their corresponding switches and connections in the numerical simulator would be troublesome. Instead, the simulator includes only one string, and its output is multiplied by the number of strings that should be active at the moment. The photocurrent of the shunted strings is not included, it is simply considered to have disappeared. We assume that all cells of the wing receive the same amount of energy, the illumination is always perpendicular, and the cells are never shadowed by other parts of the station.

S3R systems include a series of fixed voltage thresholds, that may or may not be equidistant, and the system reacts when V_{error} crosses any of them. Our simulator, meant to interface with different subsystems and adapt automatically, asks only for a voltage difference between thresholds and distributes them evenly. Comparing V_{error} with a list of thresholds proved to be too computationally inefficient. Instead, the simulation computes the modulo of V_{error} and the distance between thresholds, and interprets sudden drops as upward crossings and sudden rises as downward crossings. The number of strings is accordingly increased or decreased in one unit, except when only one string or all of them are connected. The integrator resets every night in order to ensure that the output of the device is cyclic. Fig. 3 shows a fictional V_{error} and a voltage threshold (dashed, top), and the corresponding result of the modulo operation (bottom).

A default Simulink Power System battery configured as Li-Ion has been used for the storage. The battery is connected to a CC or a CV charging module at the appropriate times, and disconnected from them when the battery is inactive. The CC circuit is limited to the 50 A limit of the ISS.⁴ In addition, the BCDU ensures that the charging stops when the battery is full, because it is not a default feature. The self-discharge of batteries has not been considered.

Only one of the eight power channels has been represented in the model for simplicity. Voltage converters are not included, which means that DDCU and BCDU are not present, and that batteries are operating at a voltage much higher than in a real scenario. There is no need of a DCSU in the simulator because the decisions normally taken by this unit are made in the main bus block instead.

The illumination model is a custom signal created in Simulink with the following constraints: 92.65 minutes, 60% of which are spent in sunlight. The irradiance ranges between zero and the value of a solar constant (1.370 kW/m²). The illumination model is connected to the SAW block, in which a string of solar cells converts the sunlight into an electrical signal. The starting condition is full illumination, right after a sunrise.

3.2 Results

Simulations of the numerical model are carried out to reproduce the behaviour of the domain controller and the batteries.

Fig. 4 shows the behaviour of the SSU during a short period of constant illumination. Every time V_{error} hits voltage thresholds, the S3R controller reacts activating or deactivating strings.

Fig. 5 shows the reaction of the system when nighttime approaches. V_{error} stays initially constant despite the decrease in illumination by opening more strings. However, when the illumination starts falling quickly, the panels

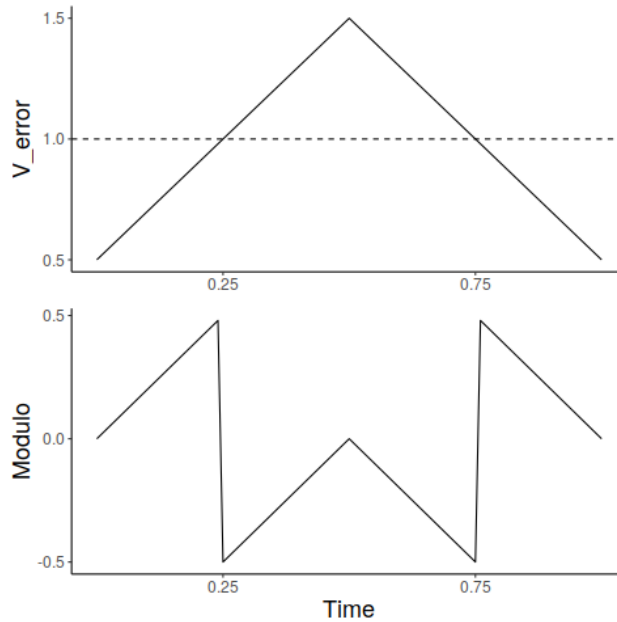

Figure 3: Representation of the modulo technique.

cannot compensate fast enough and the error increases. When all the strings are in use and V_{error} keeps rising, the domain of operation is changed.

Fig. 6 shows the changes in the domain of operation during one nominal orbit. At dusk the system moves from domain 1 (Shunt) to domain 2 (Charge), where it stays for a single simulation step and immediately moves to domain 3 (Discharge), remaining there for the duration of the eclipse. When the Sun comes back and the voltage of the bus starts dropping, the system falls back to the Charge domain, staying until the batteries are full, when the system moves to the Shunt domain until the next eclipse.

Fig. 7 shows the state of charge (SOC) of the batteries during an orbital period. They are depleted at a constant rate during the night, as is represented by the constant negative slope. After sunrise, the characteristic piecewise curve of CC-CV charging is obtained.

In order to validate the battery model, a qualitative comparison has been done between the obtained voltage and current data and the ISS Lithium-Ion battery start-up data performed by NASA.⁵ Figs. 8 and 9 show that the behaviour of the battery current and voltage, respectively, at the different stages of the cycle obtained in the simulations corresponds to the real situation. According to results in Fig. 8, the different stages of the battery are correctly represented in the model. No current flows out of the battery until the discharging domain is reached, when a positive current (a discharge) can be seen. Right after sunrise comes a short period of constant charging, until a predefined voltage threshold is reached in the battery. Afterwards, the remaining charge is introduced at constant voltage. According to results in Fig. 9, the battery stays at nominal voltage until the discharge starts and voltage decreases. During charging the voltage rises at the CC phase, and remains constant at the CV phase.

4. Lunar habitat power system

4.1 Numerical model

The numerical model of the ISS power system has been modified to take into account the particularities of the power system for a Moon habitat.

Two habitat locations at different latitudes of the Moon have been selected in order to consider different illumination conditions. The specific topography around the habitat has not been taken into account. One location of the habitat is close to the equatorial band, at 20° north latitude. This is the easiest region to access from the Earth since spacecraft launches to equatorial Earth orbits are the most efficient, and the angular difference between Earth's and Moon's equators is less than five degrees. The other location is close to the poles, at 80° north. Although this region has never been explored by humans, it is interesting because it features points of eternal light and eternal darkness. In addition, depending on the final location of the Lunar Orbital Platform-Gateway, this latitude might become more

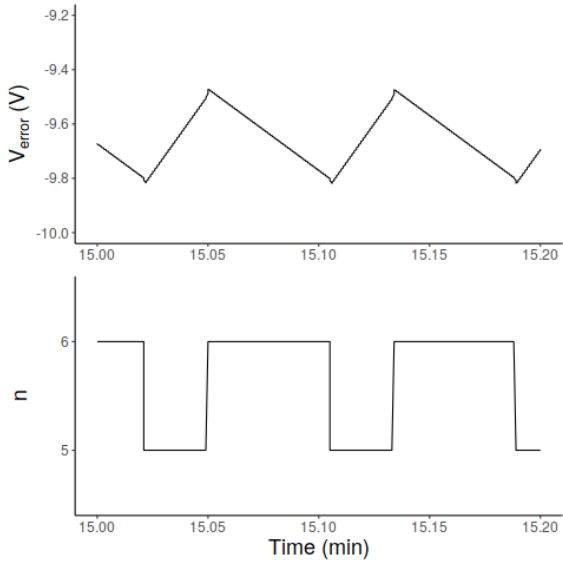

Figure 4: Detail of the SSU operation: Voltage error and number of strings.

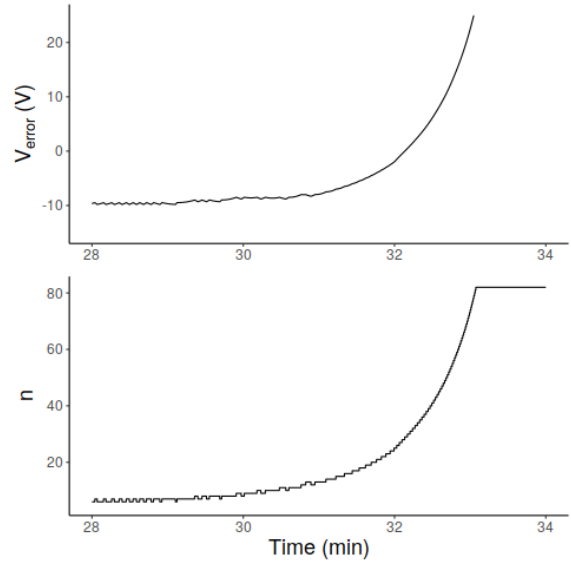

Figure 5: SSU operation at dusk: Voltage error and number of strings in use.

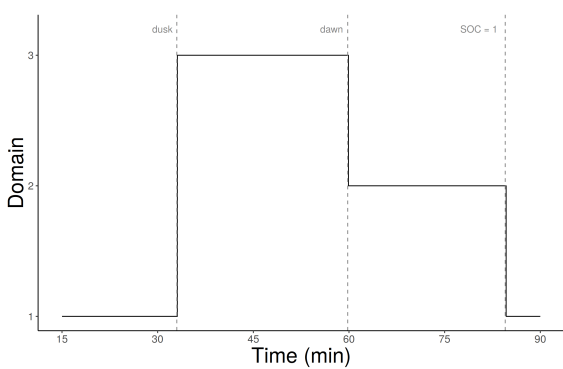

Figure 6: Changes in domain of operation during a nominal orbit.

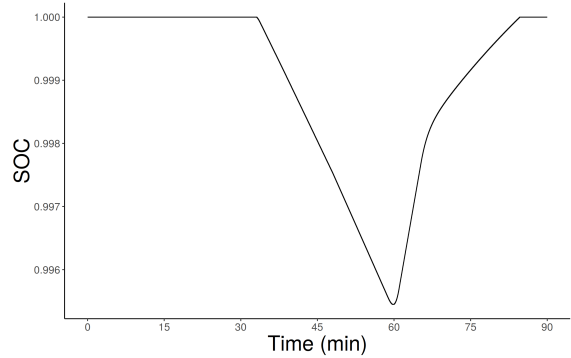

Figure 7: SOC of one of the battery packs.

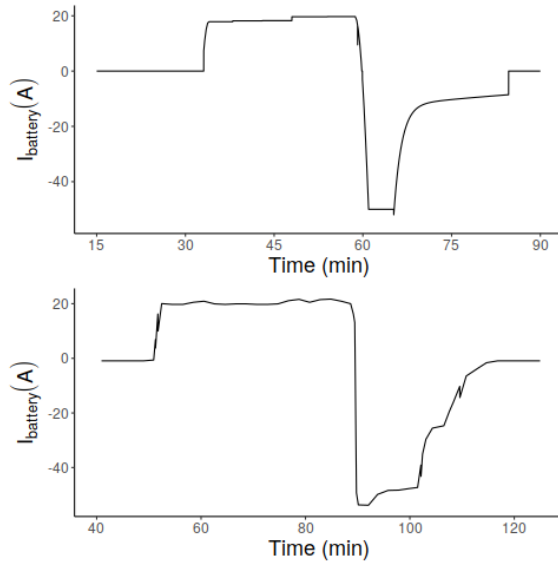

Figure 8: Battery current in simulation (top) and in reference data⁵ (bottom).

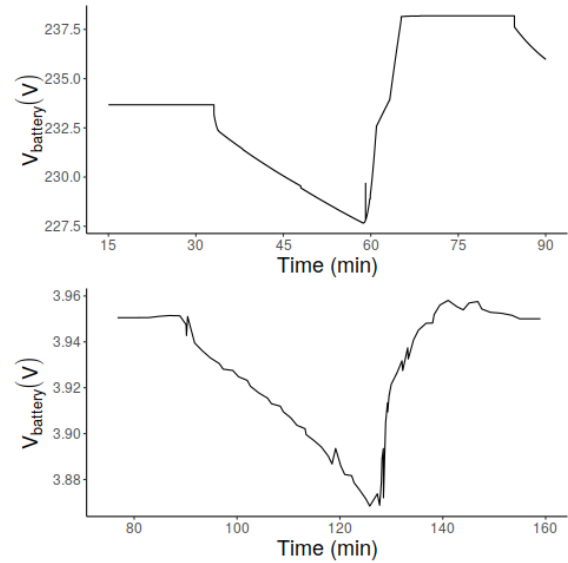

Figure 9: Battery voltage in simulation (top) and in reference data⁵ (bottom)

accessible than the equator. The longitude of the habitat location is not relevant, as the maximum illumination angle does not depend on it. The illumination in the equatorial region ranges from 0 at night to a little bit less than a solar constant at noon, while in the polar region the maximum energy received by the surface is five times lower.

Due to the long development and validation times that are intrinsic to any space mission, the hardware onboard the ISS was already outdated by the time the station began construction in 1998. A future lunar station may include some of the same components but with better performance, and also feature new technologies. The lunar habitat design may differ from the ISS in aspects such as the type of current, (AC vs. DC), the shunt unit, and the storage of energy.

The ISS uses DC because the relatively short distances between components make it unnecessary to minimize transmission losses. Low DC voltage also brings less safety concerns, and as photovoltaic energy produces DC by nature, the direct approach seems more convenient. The initial lunar habitat will be small, and therefore DC would be more convenient for the same reasons as in the ISS. In later phases in which the lunar base becomes considerably larger, the system could be changed to AC without having to replace all the components.⁷ One could also argue that AC would make sense if two habitats separated by a long distance are fed by the same power system. This scenario would require building elevated structures in order to avoid inductive coupling to some elements of the regolith, like iron, that would result in power losses even if the cables were insulated.⁷ In addition, the latest developments in High-voltage direct current (HVDC) could make AC unnecessary.

Shunt regulation is an old technique that keeps being effective and simple. Its disadvantage is the great amount of discarded energy. Nevertheless, it is expected that the lunar habitat will have power to spare for the same reason as the ISS. There are several types of shunt regulator topologies, of which S3R is the most common. The evolution of S3R known as Sequential Switching Shunt Series Regulator (S4R)⁸ adds a third possible state for the solar cell strings, so that they can also be directly connected to the batteries. Compared to S3R, the number of possible domains of operation decreases from three to two. The Battery Charger domain is now part of the S3R domain, as the batteries get their energy from the strings that the main bus is not using. A disadvantage of this approach is that batteries are not charged at their optimal voltage. However, this topology can drastically reduce the weight of the subsystem, as there is no need for a bulky charge regulator. Moreover, there are smaller energy losses, which can reduce or eliminate the need of actively cooling the regulator, and this savings in energy can compensate for the non optimal charging of the batteries.²

The characteristics of the surface of the Moon opens up some possibilities for energy storage apart from batteries, that were not available in orbit for the ISS. The presence of large amounts of solid material, a gravitational force, and terrain features make it possible. The gravitational potential in the moon can be used as an energy storage. There is the option of lifting weight using energy surplus and releasing its energy when required. Thermal generation of electricity in the Moon is currently under research.^{1,3} The idea consists in heating regolith with sunlight during the day and extracting electricity from it during the night by means of heat engines³ or thermoelectric generators.^{6,10} A thermal energy storage system would not require a PPS like the one modelled in this work, but it is unlikely that an early habitat will rely on only one source of power, especially one that has not yet been tested. Thus, this model could

be adapted to an scenario with a thermal generator providing base power and a solar panel setup for redundancy.

4.2 Results

The system simulated for the Moon habitat is based on the one for the ISS with additional batteries. As the amount of solar energy received in the two locations considered is very different, it is expected that a PPS designed to keep barely functioning a habitat near the equator would fail near the pole. The simulations run for two lunar synodic periods (29.53 days), starting right before a sunset with full batteries. The expected nominal behaviour is that the batteries will last for the whole night and then be recharged completely before the cycle is over.

At 20 °N latitude (Fig. 10) the station works normally. Even with the reduced illumination due to the Moon-Sun geometry, the system has sufficiently good capabilities to survive the night and refill the batteries in time for the next one. A faster recharge would be advisable in order to have a safety margin.

The behavior is significantly worse for a habitat farther north (Fig. 11). At 80 °N the batteries cannot be recharged fast enough and the power supply goes in a dangerous downward trend with potentially undesirable consequences.

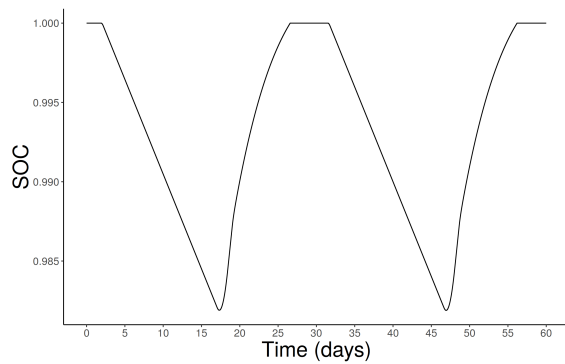

Figure 10: SOC of the batteries at 20 °N

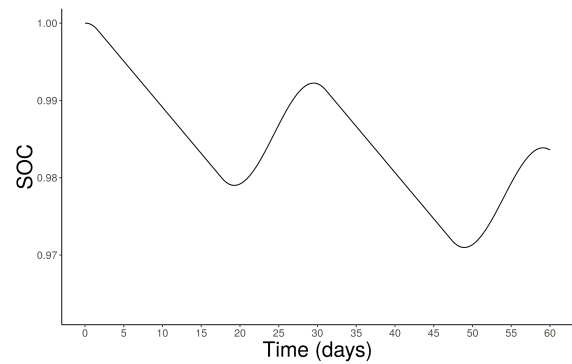

Figure 11: SOC of the batteries at 80 °N

5. Conclusions

We have presented and tested a computational model of a PPS that is adaptable and expandable. The model has been validated against real ISS data, and tested in a hypothetical scenario in order to demonstrate its future possibilities of expansion. The study in two locations of a Moon habitat confirms that the PPS works as expected. Additional tests in other latitudes would not provide much more information, as the results would be very similar. However, there are several other locations that can be analyzed in simulations of the model. For example, bases in exceptional locations such as peaks of eternal light or craters of eternal darkness, the poles of the moon, and even other atmosphere-less locations of the solar system like asteroids. The parameters of the model can also be tuned to represent different habitat designs. The simulator could be easily expanded from its current state by adding new sources (like thermoelectricity and gravitational potential energy) and sinks of energy (robots, rovers, etc.). Anyway, no matter what is added to the model, the voltage level will have to maintain its required value.

References

- [1] Ramaswamy Balasubramaniam, Robert Wegeng, Suleyman Gokoglu, Nantel Suzuki, and Kurt Sacksteder. Analysis of Solar-Heated Thermal Wadis to Support Extended-Duration Lunar Explorations. In *47th AIAA Aerospace Sciences Meeting Including The New Horizons Forum and Aerospace Exposition*, Orlando, Florida, January 2009. American Institute of Aeronautics and Astronautics.
- [2] A Capel and P Perol. Comparative performance evaluation between the S4R and the S3R regulated bus topologies. In *Proceedings of the IEEE 32nd Annual Power Electronics Specialists Conference*, volume 3, pages 1963–1969, 2001.
- [3] Blai Climent, Oscar Torroba, Ricard González-Cinca, Narayanan Ramachandran, and Michael D. Griffin. Heat Storage and Electricity Generation in the Moon during the Lunar Night. *Acta Astronautica*, 93:352—358, 2014.

- [4] P. Dalton and F. Cohen. International space station nickel-hydrogen battery on-orbit performance. In *IECEC '02. 2002 37th Intersociety Energy Conversion Engineering Conference, 2002.*, pages 106–113, Washington, WA, USA, 2004. IEEE.
- [5] Penni J Dalton, Tim North, Ebony Bowens, and Sonia Balcer. International Space Station Lithium-Ion Battery Start-Up, April 2017.
- [6] Patrick Fleith, Aidan Cowley, Pablo López Córdoba, Rebecca Frank, Aarón Valle Lozano, Alberto Canals Pou, and Ricard González-Cinca. In-Situ Approach for Thermal Energy Storage and Thermoelectricity Generation on the Moon (submitted to *Planetary and Space Science*). 2019.
- [7] Toby Mintz, Edward A Maslowski, Anthony Colozza, Willard McFarland, Kevin P Prokopius, Analex Corporation, Patrick J George, and Sam W Hussey. Simulation of a Lunar Surface Base Power Distribution Network for the Constellation Lunar Surface Systems. Technical report, John H. Glenn Research Center (NASA), 2010.
- [8] Dan Olsson, James Edward Haines, and Philippe Alfred Perol. A device for generating electrical energy for a power supply bus, 2000.
- [9] P Perol. Another Look at the Sequential Switching Shunt Regulator. In *Proceedings of the Fifth European Space Power Conference*, pages 79–84, 1998.
- [10] Pol Serra and Ricard González-Cinca. Thermoelectric generators for long-duration lunar missions. In *European Conference for Aeronautics and Space Sciences (EUCASS)*, 2019.
- [11] The Boeing Company. International Space Station Electric Power System. Technical report.