

Daniel F. Llana, Guillermo Íñiguez-González*, Joaquín Montón and Francisco Arriaga

In-situ density estimation by four nondestructive techniques on Norway spruce from built-in wood structures

<https://doi.org/10.1515/hf-2018-0027>

Received February 7, 2018; accepted May 1, 2018; previously published online June 5, 2018

Abstract: Needle penetration resistance (NPR), screw withdrawal resistance (SWR), core drilling (CD) and drilling chips extraction (DCE) are nondestructive and semi-destructive techniques used to estimate density in timber structures. In most of the previous studies, these techniques were tested in clear sawn timber and clear specimens. The goal of the present paper is to study the relationship between density and these techniques by means of five different devices in whole pieces of timber from built-in engineering structures, which are from 12 4.5-m long structural timber joists of Norway spruce from a 19th century building in Barcelona (Catalonia, Spain). Although determination coefficients (R^2) for density estimation models were lower than those from clear timber, the results obtained confirmed that these four techniques are suitable for *in-situ* density estimation of woods in buildings. The best results were obtained by CD (the bigger the bit, the higher the correlation), followed by DCE, and SWR. The worst correlation was found for NPR

devices, but the results could be probably improved with more measurements.

Keywords: core drilling (CD), drilling chips extraction (DCE), needle penetration resistance (NPR), nondestructive testing (NDT), probing, screw withdrawal resistance (SWR)

Introduction

Nondestructive testing (NDT) methods (needle and drill penetration resistance, screw and nail withdrawal resistance and core drilling) are mainly used to estimate density in standing trees and logs (Rinn et al. 1996; Ponneth et al. 2014; da Silva et al. 2017), and in structural timber (Görlacher 1987; Bobadilla et al. 2007; Esteban et al. 2009; Íñiguez-González et al. 2015a; Llana et al. 2018). Hardness has a good relationship to density (Ceccotti and Togni 1996). Sclerometers are also suited to density estimation (Soriano et al. 2015). According to Carballo et al. (2009), the most common probing techniques in Spain for density estimation are NPR, performed with the instrument Pilodyn 6J Forest (Proceq, Schwerzenbach, Switzerland), and SWR (instrument SWR Meter, Fakopp Enterprise Bt., Sopron, Hungary). In recent years, the techniques of core drilling (Montón 2012) and drilling chips extraction were also tested successfully for density determination (Martínez 2016). The most relevant approaches NPR, SWR, CD and DCE are summarized in the following:

Needle penetration resistance (NPR): The Pilodyn device was developed in Sweden in the 1970s and is based on the NPR method. The instrument operates by shooting a blunt pin into wood with an exactly known energy, after which the penetration depth is read on a scale (Hoffmeyer 1978). It is popular for testing standing trees (Cown 1978), poles (Morrell et al. 1994), and built-in wood structures (Görlacher 1987). The Wood Pecker test hammer (DRC, Ancona, Italy) measures the NPR depth in wood after one or several constant-energy strikes. The main difference between this and other NPR testers is that it is possible to strike the needle several times and record penetration depth after each strike.

***Corresponding author: Guillermo Íñiguez-González,** Timber Construction Research Group, Universidad Politécnica de Madrid, Madrid, Spain; and Department of Forestry and Environmental Engineering and Management, MONTES (School of Forest Engineering and Natural Resources), Universidad Politécnica de Madrid, Madrid, Spain, e-mail: guillermo.iniguez@upm.es. <http://orcid.org/0000-0003-2917-842X>

Daniel F. Llana: Timber Construction Research Group, Universidad Politécnica de Madrid, Madrid, Spain; and Timber Engineering Research Group, National University of Ireland Galway, Galway, Ireland. <http://orcid.org/0000-0001-7758-9456>

Joaquín Montón: GICITED (Interdisciplinary Group on Building Science and Technology), Department of Architectural Technology, EPSEB (Barcelona School of Building Construction), Universitat Politècnica de Catalunya, Barcelona, Spain. <http://orcid.org/0000-0002-3781-4783>

Francisco Arriaga: Timber Construction Research Group, Universidad Politécnica de Madrid, Madrid, Spain; and Department of Forestry and Environmental Engineering and Management, MONTES (School of Forest Engineering and Natural Resources), Universidad Politécnica de Madrid, Madrid, Spain. <http://orcid.org/0000-0001-5535-0786>

Screw withdrawal resistance (SWR): SWR force is known to be correlated with sawn timber density (Cockrell 1933) and timber product density (Shalbahfan et al. 2013). The SWRM is a portable device that was developed in the 1990s (Divós et al. 1994) and it was successfully applied for density estimation of several Spanish-sourced species.

Core drilling (CD): The CD technique, based on the increment borer developed by Pressler (1866), has been used for several decades for specific gravity estimation in standing trees (Walters and Bruckmann 1964; Bergsten et al. 2001; Moreno-Chan et al. 2010). Since the end of the last century, the compressive strength of small diameter cores from built-in wood structures have been tested, and it is also used as an estimator of density (Kasal 1997). CD is a semi-destructive technique leading to density estimation of samples, which is also suitable for species identification. Cylindrical specimens (5–22 mm \varnothing) are removed from timber using a commercial core bit. According to Kasal and Tannert (2010), the holes left by CD are smaller than some natural defects, such as knots, and does not compromise strength. Falk et al. (2003) performed a four-point bending test on Douglas-fir specimens with 25.4 mm diameter holes in their midspan axis at different heights. A hole in the compression zone had no significant influence on bending strength.

Drilling chips extraction (DCE): Paul and Baudendistel (1943) described a procedure for the *in-situ* determination of specific gravity from auger chips. A new device known as the RML Wood Extractor (Timber Construction Research Group, GICM-UPM, Madrid, Spain) was developed by Martínez (2016) based on the DCE technique (patented by Martínez and Bobadilla 2013). Bobadilla et al. (2013) presented a prototype of the instrument in a wood NDT conference in Madison. The device was designed to be coupled to a commercial drill to collect all of the chips produced during drilling inside a paper bag filter. Density is determined from the mass of chips and the volume of the hole.

According to several authors (Bues et al. 1987; Bobadilla et al. 2007; Íñiguez 2007; Calderón 2012; Martínez 2016) there are no significant differences between radial (R) and tangential (T) probing measurements, aside from the fact that it is rarely possible to select the probing direction *in-situ*. Most of the previous research was done in clear timber (Salamanca 2017; Martínez et al. 2018) or in slices from new timber free of singularities (Bobadilla et al. 2007; Íñiguez et al. 2010; Casado et al. 2012; Montón 2012; Montero 2013; Íñiguez-González et al. 2015b). However, wood as part of built-in structures was seldom used free of singularities (Casado et al. 2012; Morales-Conde et al. 2014).

Obviously, the measurements in clear timbers or clear slices provide results with less scattering than in less homogeneous woods with singularities, such as knots with twice as high densities compared to clear wood. Studies with clear timber result in the lowest R^2 using NPR, followed by SWR, while the highest and best R^2 values can be achieved by CD and DCE, but a statistically relevant comparison of the techniques are not yet available. Specific research is needed to make the results of the known techniques comparable, and this was the purpose of the present study.

Materials and methods

Materials: Twelve large cross-section Norway spruce joist specimens from a dismantled 19th century building in the Sants-Montjuïc district of Barcelona (Catalonia, Spain) were tested. Their average dimensions: 4520 mm length with a cross-section of 76 × 226 mm². Each specimen was microscopically identified as Norway spruce [*Picea abies* (L.) Karst.] in the Timber Technology Laboratory of the School of Forest Engineering and Natural Resources, UPM (Madrid, Spain). Specimens were stored in the laboratory until a constant MC had been achieved. The equilibrium moisture content (EMC) was determined by the oven dry method according to standard EN 13183-1 (2002) based on specimen slices free of knots and resin pockets according to EN 408 (2012). The mean EMC of the 12 specimens was 11.4% (10.9–12.7%). Furthermore the mass and dimensions of whole specimens were recorded to determine density as mass/volume ratio with a mean density of 434 kg m⁻³ (402–510 kg m⁻³).

NDT experiments: Five different NDT variables were measured only once in each specimen (whole piece) avoiding areas close to the pith and other singularities such as knots or resin pockets and not taking into account R or T directions: (1) NPR depth, with the Pilodyn 6 J Forest commercial device (Proceq, Schwerzenbach, Switzerland) (Figure 1a). This consists of a calibrated spring that releases a 2.5 mm diameter steel needle with a constant energy of 6 J and the penetration depth of it is measured in mm. (2) NPR depth, with the commercial device Wood Pecker (DRC, Ancona, Italy) (Figure 1b). This modified sclerometer inserts a 2.5 mm diameter steel needle with constant energy, striking several times. In this study, the penetration depth was measured in mm after one, three and five strikes. (3) SWR force was measured with the commercial device SWRM (Fakopp Enterprise Bt., Sopron, Hungary) (Figure 1c). The screw applied was a Heco-Fix-Plus (Heco-Schrauben GmbH & Co. KG, Schramberg, Germany) with a Spax (PZD) type head. It is a yellow zinc plated, 4-mm diameter 70-mm long screw, with a penetration depth of 20 mm. SWR force is measured in kN. (4) The mass and volume of cylindrical cores were measured by means of two commercial core bits (Figure 1d) with external diameters of 14 and 22 mm and internal \varnothing of 10 and 16 mm, respectively. (5) The mass of chips was measured by a RML Wood Extractor device (GICM-UPM, Madrid, Spain) coupled to a commercial PSB 50 drill (Bosch, Gerlingen, Germany) (Figure 2). An 8 mm \varnothing bit was drilled into a standard 47 mm depth into the wood specimens (hollow volume is known) combined with vacuum chip collection.

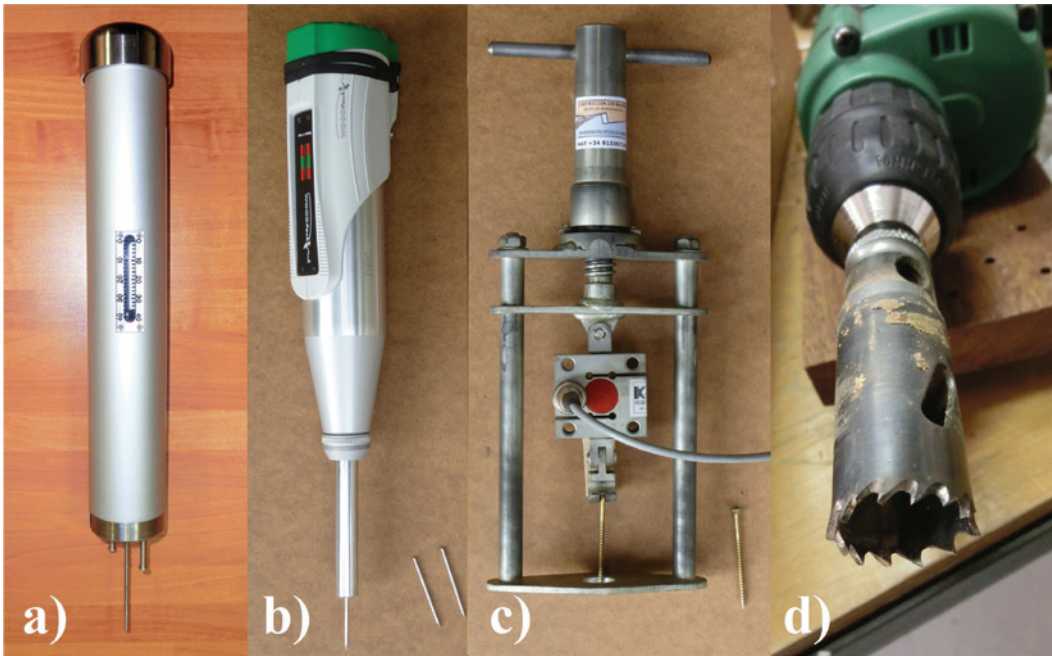

Figure 1: Probing devices used.
(a) Pilodyn 6J Forest, (b) Wood Pecker, (c) SWRM, (d) core drill.

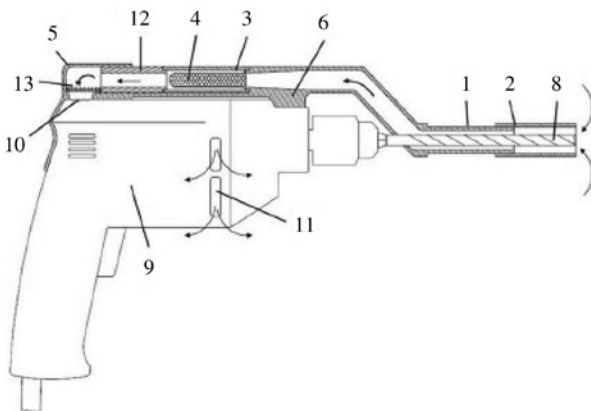

Figure 2: RML Wood Extractor (1) coaxial pipes, (2) telescopic system, (3) cartridge, (4) paper filter bag, (5) enveloping structure, (6) clamp, (7) spring, (8) drill bit, (9) power drill, (10) air intake, (11) side holes, (12) telescopic tube, (13) spring. (Republished from Martínez 2016 with permission.)

Results and discussion

Table 1 summarizes EMCs, density and NPR depth obtained by the Pilodyn and Wood Pecker, and the SWR force via SWRM, and the densities determined with two CDs and the chip mass approach with the RML Wood Extractor device. As EMCs in Table 1 are really close to 12%, thus no MC correction factors were applied to density and NDT measurements. Coefficients of variation

(COV) of mean values are similar for the devices, except for the SWRM, which is higher as was found by several other authors, namely Montón (2012) in radiata pine, Llana (2016) in Salzmann pine and Martínez (2016) in several species. This could be partly explained by the influence of operators, as the hand turning speed of SWRM affects the results.

To estimate the density from different devices, simple linear regression analyses were performed (Eq. 1, Table 2 and Figure 3):

$$\text{Den} = a * \text{VAR} + b, \quad (1)$$

where Den (kg m^{-3}) is the specimen's density; VAR is the variable measured with NPR depth (mm), SWR is the force (kN), core density (kg m^{-3}) or chip mass (g).

Density estimation results with Pilodyn gave a R^2 (22%) that is lower than those found in the literature for sawn timber slices (from 31 to 61%). Bobadilla et al. (2007) estimated of 395 pieces' density of the species radiata, Scots and Salzmann pine with a determination coefficient (R^2) of 39%. Íñiguez et al. (2010) found a higher density coefficient (61%) based on 266 pieces of the same three species and maritime pine. Montón (2012) reported a R^2 of 31% for density estimation of 60 radiata pine specimens. Montero (2013) obtained a R^2 of 32% with 218 new timber specimens of Scots pine. Llana (2016) reported a R^2 of 56% using new specimens of radiata, Scots, Salzmann and maritime pine.

Table 1: EMC, density, NPR depth, SWR force, core density and chip mass results.

Specimen no	MC		Density		Pilodyn		Wood Pecker		SWRM		Core drill		RML	
	EMC (%)	EMC (%)	Density (kg m ⁻³)	Density (kg m ⁻³)	NPR depth (mm)	NPR depth (mm)	1 strike NPR depth (mm)	3 strikes NPR depth (mm)	5 strikes NPR depth (mm)	SWR force (kN)	SWR force (kN)	Bit Ø 14 mm density (kg m ⁻³)	Bit Ø 22 mm density (kg m ⁻³)	Chips mass (g)
1	11.5	11.5	402	402	16.0	10.7	21.7	28.5	1.00	410	418	1.05		
2	11.0	11.0	412	412	18.0	10.2	18.3	23.7	1.13	429	416	1.21		
3	10.9	10.9	413	413	16.0	11.3	20.1	26.2	1.14	452	414	1.02		
4	11.4	11.4	420	420	14.0	8.9	17.7	23.9	1.31	462	448	1.14		
5	11.2	11.2	420	420	13.0	6.7	13.7	18.5	1.34	434	462	1.21		
6	11.0	11.0	426	426	14.0	10.3	18.2	22.7	1.12	474	458	1.24		
7	11.7	11.7	434	434	16.0	8.8	16.2	21.6	1.35	501	494	1.25		
8	11.9	11.9	435	435	13.0	10.5	17.3	22.4	1.17	464	472	1.16		
9	11.8	11.8	438	438	12.0	9.9	16.6	21.2	1.79	496	467	1.13		
10	12.7	12.7	439	439	12.0	9.4	16.3	19.0	1.26	484	489	1.28		
11	10.9	10.9	463	463	14.0	10.1	17.1	21.5	1.07	471	486	1.24		
12	11.0	11.0	510	510	13.0	8.7	15.3	19.8	2.11	630	711	1.49		
Mean (COV)	11.4 (4.8)	11.4 (4.8)	434 (6.6)	434 (6.6)	14.3 (13.1)	9.6 (12.7)	17.4 (12.1)	22.4 (12.9)	1.32 (24.5)	475 (11.7)	478 (16.5)	1.20 (10.1)		

Table 2: Coefficients for Eq. 1 (Den = a*VAR + b) and R² and P-values of the predictions.

Device	Variable VAR	a	b	R ² (%)	P-value
Pilodyn	NPR depth	-7.25	538	22	0.12
Wood	1 strike NPR depth	-5.77	490	6	0.44
Pecker	3 strikes NPR depth	-7.25	560	28	0.08
	5 strikes NPR depth	-5.70	562	33	0.05
SWRM	SWR force	64.69	349	53	0.01
Core drill	Bit Ø 14 mm core dens	0.47	209	84	0.00
	Bit Ø 22 mm core dens	0.34	270	89	0.00
RML	Chips mass	198.97	195	70	0.00

The Wood Pecker R² data are higher with more strikes (from 6 to 33%), but these data are still much lower than the 75% obtained by Salamanca (2017) with three strikes in small clear wood specimens from 10 species (black poplar, European oak, iroko, missanda, sweet chestnut, western red cedar, radiata, Scots, Salzmann and maritime pine).

SWRM R² (53%) is within the range cited by other authors (49–74%). Casado et al. (2005) estimated the density of 39 joists of Scots pine from a built-in structure, with a R² of 62%. Bobadilla et al. (2007) and Íñiguez et al. (2010) reported a R² of 49% and 61%, respectively, in radiata, Scots and Salzmann pine new structural timber specimens. Casado et al. (2012) reported a 74% R² on 217 new timber slices of black poplar. Íñiguez-González et al. (2015b) found a R² of 57% in 150 new timber specimens of radiata pine. Llana (2016) obtained a 68% R² for radiata, Scots, Salzmann and maritime pine.

R² CD results are slightly higher for bigger cores (84–89%), and they are similar to the 88% and 80% data reported by Montón (2012) and Íñiguez-González et al. (2015b), respectively, and higher than 48% found by Morales-Conde et al. (2014).

Density estimation from chip mass gave a 70% R², which is lower than the 84% reported by Martínez et al. (2018) in clear wood specimens of radiata, Scots, Salzmann and maritime pine. In general, the higher is the semi-destructive character of the measurement, the greater is the correlation. At higher material removal rate, the density estimation improves.

As the P-value in the analysis of variance (ANOVA) in the Table 1 is <0.05 for SWRM, core drill and RML, there is a significant relationship between density and the variables studied at a 95% confidence level. However, the confidence level is lower for the Pilodyn and Wood Pecker instruments. In the case of the Wood Pecker the confidence level rises with increasing numbers of strikes.

Figure 3 shows the linear regressions for density estimation for each device with 12 measurements, one from

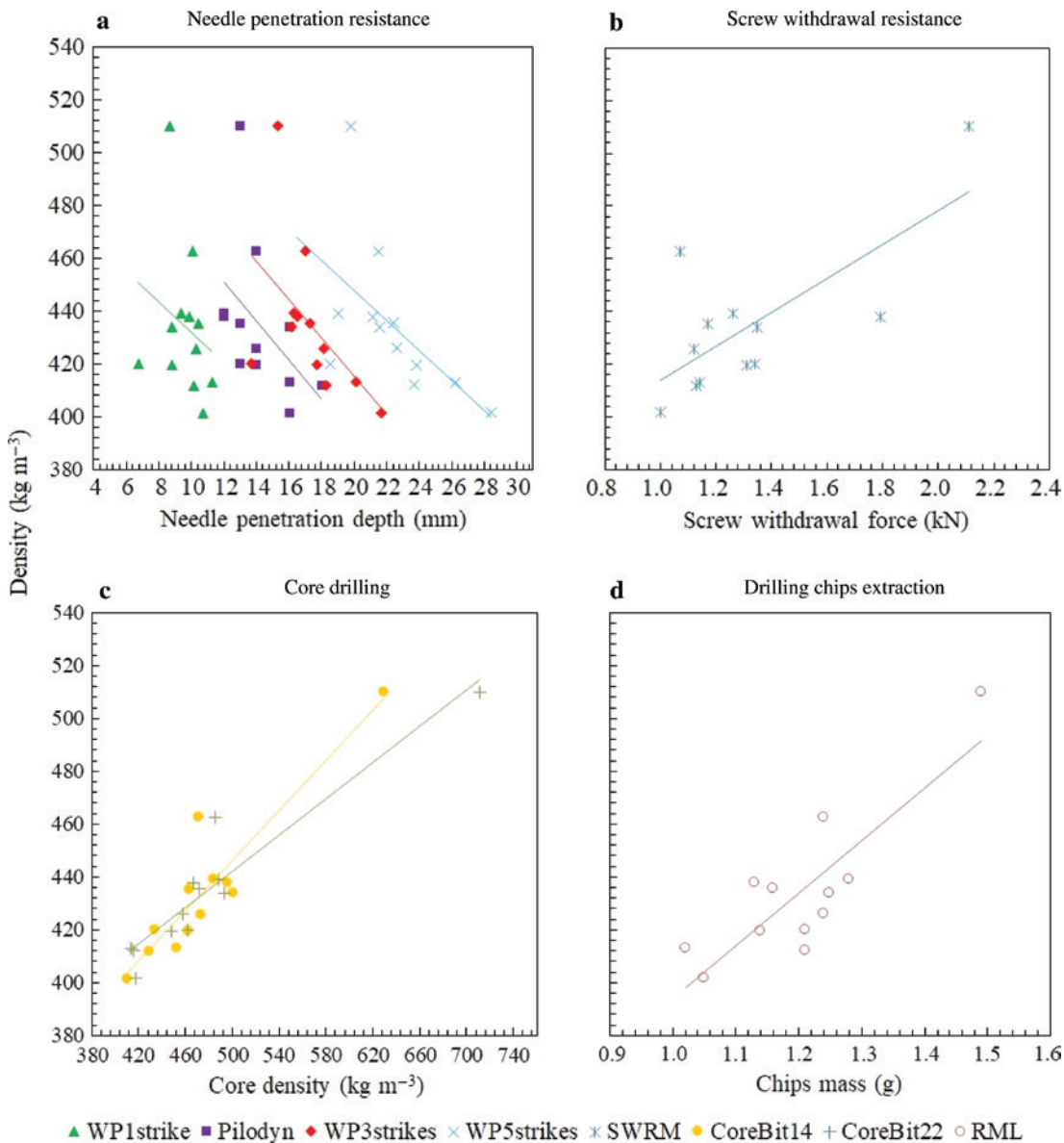

Figure 3: Linear regressions. (a) Wood Pecker and Pilodyn, (b) SWRM, (c) core drill, (d) RML Wood Extractor.

each specimen. One specimen showed a higher density (510 kg m^{-3}) compared with the mean value of the other 11 pieces (427 kg m^{-3}) in spite of the fact that the same species were identified microscopically. Although this specimen was analyzed in detail to detect abnormal characteristics (ring growth, resin content, etc.), no reason for the deviation was found.

Table 3 shows exactly the same mean density as was expected, because Eq. 1 was created based on these data. When Eq. 1 is applied on every single specimen, the lowest errors are found for the CD method as was expected, because the real density is estimated from the density of a core. RML Wood Extractor, SWRM and Wood Pecker 3 and 5 strikes

deliver error values double than the core, being the highest ones achieved with Pilodyn and Wood Pecker 1. According to Table 2, Wood Pecker R^2 is low and SWRM R^2 is medium, but the errors are similar to RML with a high R^2 .

If Eq. 1 is applied to every single specimen, estimated densities can be obtained. Figure 4 shows the differences between measured and estimated densities. In the case of needle penetration devices (Figure 4a), all densities are overestimated in the range of low real densities, but are more accurate around 430 kg m^{-3} . Figure 4b shows that SWRM also overestimates low densities and that CD is the most accurate instrument, especially if equipped with a 22 mm bit.

Table 3: Measured and estimated densities.

Spec. no	Density (kg m ⁻³) Mass/volume	Estimated density (kg m ⁻³) and error (%)								
		Wood Pecker					Core drill			RML
		Pilodyn	1 strike	3 strikes	5 strikes	SWRM	Bit Ø 14 mm	Bit Ø 22 mm		
1	402	422	428	403	400	414	403	414	404	
		5.0	6.6	0.3	0.5	3.1	0.4	3.0	0.6	
2	412	407	431	428	427	422	412	413	436	
		1.2	4.6	3.8	3.6	2.5	0.1	0.2	5.8	
3	413	422	425	414	413	423	423	412	398	
		2.1	2.8	0.3	0.1	2.4	2.5	0.2	3.6	
4	420	436	439	432	426	434	428	424	422	
		3.9	4.5	2.9	1.5	3.4	2.0	1.1	0.6	
5	420	443	451	461	457	436	414	429	436	
		5.6	7.3	9.7	8.7	3.8	1.3	2.1	3.8	
6	426	436	430	428	433	422	433	428	442	
		2.4	1.0	0.6	1.6	1.0	1.7	0.4	3.7	
7	434	422	439	443	439	436	446	440	444	
		2.9	1.1	2.0	1.2	0.6	2.8	1.3	2.3	
8	435	443	429	435	434	425	429	432	426	
		1.8	1.4	0.2	0.3	2.4	1.5	0.7	2.2	
9	438	451	433	440	441	465	444	430	420	
		2.9	1.2	0.5	0.8	6.2	1.4	1.7	4.1	
10	439	451	436	442	453	431	438	438	450	
		2.6	0.8	0.7	3.3	1.9	0.2	0.3	2.4	
11	463	436	431	437	440	418	432	437	442	
		5.7	6.7	5.6	5.0	9.6	6.6	5.5	4.5	
12	510	443	440	449	449	486	508	515	492	
		13.1	13.8	11.9	11.9	4.8	0.5	0.9	3.6	
Mean	434	434	434	434	434	434	434	434	434	
Dens. (COV)	(6.6)	(3.1)	(1.6)	(3.5)	(3.8)	(4.8)	(6.1)	(6.2)	(5.5)	
Mean error (%)		4.1	4.3	3.2	3.2	3.5	1.7	1.4	3.1	

Data from Eq. 1.

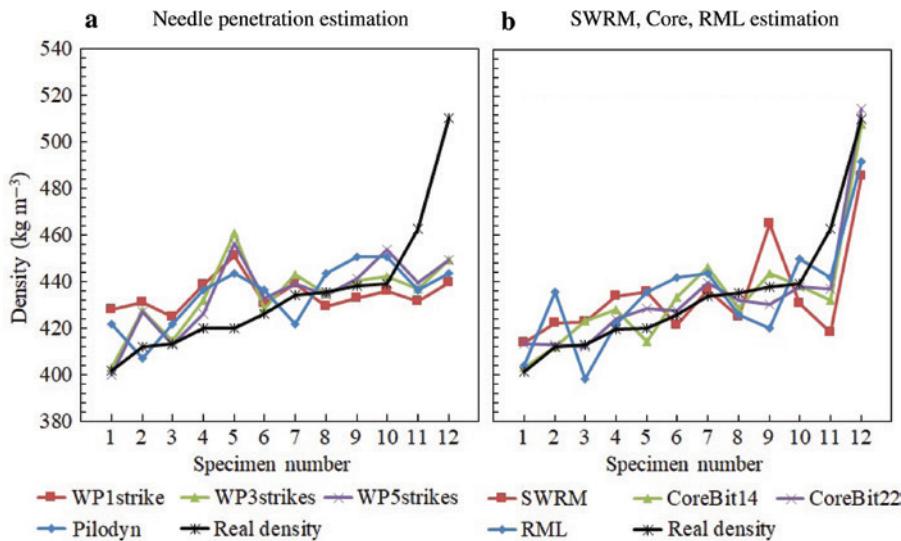

Figure 4: Experimental and estimated densities by different devices. (a) Wood Pecker and Pilodyn, (b) SWRM, core drill and RML Wood Extractor.

In general, the more material that is removed, the higher is the correlation as already stated. This was also seen on the CD approach, where bigger cores resulted in better correlation data. Core drilling is the only method that estimates real density from other density (core density), and R^2 data are higher and errors are lower than in case of other methods.

From a practical point of view, the assessment of built-in structures is more time consuming and costly. The less reliable density estimations were found by Pilodyn (with only one measurement per specimen), but this device is the fastest. In future research works, more than one measurement should be performed with Pilodyn to achieve a more reliable statistical evaluation of this instrument. Görlacher (1987) showed an R^2 increment from 41% from one measurement to 85% for 16 measurements on clear Norway spruce timber. In the case of the Wood Pecker, at least five strikes are recommended. As the other devices delivered better results, which are similar to those in the literature, it can be safely concluded that only one measurement per specimen is needed to estimate density based on the devices SWRM, core drill and RML Wood Extractor.

Conclusions

All of the NDT techniques studied (NPR, SWR, CD and DCE) are suitable for *in-situ* density estimation of built-in timber structures, although correlations are lower than on clear specimens. Semi-destructive systems with higher degree of degradation gave better results than the less destructive ones. CD gave the best R^2 (84–89%, the bigger the bit, the larger the R^2), which was closely followed by the DCE principle performed with the new RML Wood Extractor device (70%). SWR with SWRM gave a R^2 (53%) similar to data presented in the literature. However, NPR showed poor R^2 values and lower confidence levels. In the case of the Wood Pecker, more strikes gave better R^2 (33% for five strikes) and higher confidence levels, while the Pilodyn results in the worst R^2 (22%). Another important factor that should be taken into account is the time-cost variable. Although the Pilodyn gave the worst R^2 (22%) and a relationship with density at a confidence level of 87%, it is the least time-consuming method and should be studied to find out how to improve its performance.

Acknowledgments: The authors would also like to thank Mr. Pere Linares from House Habitat, Olesa de Montserrat, Spain, for freely supplying the material, Mrs. María Alejandra García Coll and Mr. Tomás Bobadilla Fonollá for their helpful technical assistance in the Materials

Laboratory of the UPC, Barcelona, Spain, and Mr. Carlos Osuna Sequera for their help with species identification in the Timber Laboratory of the UPM, Madrid, Spain.

Author contributions: All the authors have accepted responsibility for the entire content of this submitted manuscript and approved submission.

Research funding: The authors thank the Ministerio de Economía y Competitividad [Spanish Ministry of Economy and Competitiveness]. Plan Nacional ID 2013–2016. Proy.: BIA 2014-55089-P.

Employment or leadership: None declared.

Honorarium: None declared.

References

- Bergsten, U., Lindeberg, J., Rindby, A., Evans, R. (2001) Batch measurements of wood density on intact or prepared drill cores using X-ray microdensitometry. *Wood Sci. Technol.* 35:435–452.
- Bobadilla, I., Íñiguez, G., Esteban, M., Arriaga, F., Casas, L. (2007) Density estimation by screw withdrawal resistance and probing in structural sawn coniferous timber. *Proceedings of the 15th International Symposium on Nondestructive Testing of Wood.* September 10–12. Duluth, MN, USA. pp. 247–251.
- Bobadilla, I., Martínez, R.D., Calvo, J., Arriaga, F., Íñiguez-González, G. (2013) First steps in wood density estimation using a conventional drill. *18th International Nondestructive Testing and Evaluation of Wood Symposium.* September 24–27. Madison, WI, USA. pp. 112–118.
- Bues, C.T., Schulz, F., Eichenseer, F. (1987) Untersuchung des Ausziehungswiderstands von Nägeln und Schrauben in Kiefernholz [Comparative investigations on the withdrawal resistance of nails and screws in pine]. *Holz Roh Werkst.* 45:514.
- Calderón, L. (2012) Estudio sobre la influencia del contenido de humedad de la madera en ensayos no destructivos para *Pinus nigra* Arn., *Pinus radiata* D. Don y *Pinus sylvestris* L. [Study of wood moisture content influence on nondestructive measurements on *Pinus nigra* Arn., *Pinus radiata* D. Don and *Pinus sylvestris* L.]. PFC E.U.I.T. Forestal. UPM. Madrid. 109 p. PDF File: <http://oa.upm.es/14396/>.
- Carballo, J., Hermoso, E., Díez, M.R. (2009) Ensayos no destructivos sobre madera estructural. Una revisión de 30 años en España. [Non-destructive testing on structural timber. A review of the last 30 years in Spain]. *Revista forestal (Costa Rica)* 6:1–16.
- Casado, M.M., Pinazo, O., Basterra, L.A., Acuña, L. (2005) Técnicas de ensayo no destructivas en madera estructural mediante extracción de tornillos. Aplicación en viguetas de forjado de un edificio singular. [Non destructive technique of screw pullout resistance applied to structural timber joists from a singular building]. *Actas del IV congreso nacional de protección de la madera.* CIDEMCO. June 16–17. San Sebastián, Spain. 12 p.
- Casado, M.M., Acuña, L., Basterra, L.A., Ramón-Cueto, G., Vecilla, D. (2012) Grading of structural timber of *Populus x euroamericana* clone I-214. *Holzforschung* 66:633–638.

- Ceccotti, A., Togni, M. (1996) NDT on ancient timber beams: assessment of strength/stiffness properties combining visual and instrumental methods. Proceedings of 10th International symposium on nondestructive testing of wood. August 26–28. Lausanne, Switzerland, pp. 379–388.
- Cockrell, R.A. (1933) A study of the screw-holding properties of wood. Tech. Pub. 44. Bulletin of the New York State College of Forestry of Syracuse, N.Y. 27 p.
- Cown, D.J. (1978) Comparison of the Pilodyn and Torsiometer methods for the rapid assessment of wood density in living trees. N.Z. J. Forestry Sci. 8:384–391.
- da Silva, J.T., Wang, X., Vidaurre, G.B. (2017) Assessing specific gravity of young Eucalyptus plantation trees using a resistance drilling technique. *Holzforschung* 71:137–145.
- Divós, F., Jarasi, J., Hodasz, E., Nemeth, L. (1994) Screw withdrawal force as strength predictor. Proceedings of 1st European Symposium on Nondestructive Evaluation of Wood. September 21–23. Sopron, Hungary. p. 532.
- Esteban, M., Bobadilla, I., Arriaga, F., Íñiguez, G., García, H. (2009) NDT applied to estimate the mechanical properties of the timber of an ancient structure in Valsaín, Segovia (Spain). Proceedings of 16th International Symposium on Nondestructive Testing of Wood. October 12–14. Beijing, China. pp. 152–157.
- European Standard. (2002) EN 13183-1. Moisture content of a piece of sawn timber. Part 1: Determination by oven dry method. European Committee of Standardization (CEN), Brussels, Belgium.
- European Standard. (2012) EN 408:2010 + A1:2012. Timber structures. Structural timber and glued laminated timber. Determination of some physical and mechanical properties. European Committee of Standardization (CEN), Brussels, Belgium.
- Falk, R.H., DeVisser, D., Plume, G.R., Fridley, K.J. (2003) Effect of drilled holes on the bending strength of large dimension Douglas-fir lumber. *Forest Prod. J.* 53:55–60.
- Görlacher, R. (1987) Zerstörungsfreie Prüfung von Holz: Ein in „situ“-Verfahren zur Bestimmung der Rohdichte. [Non-destructive testing of wood. In situ-method for determining wood density]. *Holz Roh Werkst.* 45:273–278.
- Hoffmeyer, P. (1978) The Pilodyn as a non-destructive tester of the shock resistance of wood. Proceedings of 4th Nondestructive Testing of Wood Symposium. August 28–30. Vancouver, WA, USA. pp. 47–66.
- Íñiguez, G. (2007) Clasificación mediante técnicas no destructivas y evaluación de las propiedades mecánicas de la madera aserrada de coníferas de gran escuadría para uso estructural. [Grading by non destructive techniques and assessment of the mechanical properties of large cross section coniferous sawn timber for structural use]. Doctoral thesis. Universidad Politécnica de Madrid, ETS de Ingenieros de Montes. 223 p. PDF file: <http://oa.upm.es/415>.
- Íñiguez, G., Arriaga, F., Esteban, M., Bobadilla, I., González, C., Martínez, R.D. (2010) In situ non-destructive density estimation for the assessment of existing timber structures. Proceedings of World Conference of Timber Engineering (WCTE). June 20–24. Riva di Garda, Italy. 8 p.
- Íñiguez-González, G., Arriaga, F., Esteban, M., Llana, D.F. (2015a) Reference conditions and modification factors for the standardization of nondestructive variables used in the evaluation of existing timber structures. *Constr. Build. Mater.* 101:1166–1171.
- Íñiguez-González, G., Montón, J., Arriaga, F., Segué, E. (2015b) In-situ assessment of structural timber density using non-destructive and semi-destructive testing. *BioResources* 10:2256–2265.
- Kasal, B. (1997) Use of cylindrical specimens in evaluation of some mechanical properties of in-situ wood members. Proceedings of the 5th International Conference on Structural Studies, Repairs and Maintenance of Historical Buildings (STREMAH V). San Sebastian, Spain. pp. 103–109.
- Kasal, B., Tannert, T. In Situ Assessment of Structural Timber. RILEM State of the Art Reports, vol. 7. Springer, Heidelberg, 2010. 124 p.
- Llana, D.F. (2016) Influencia de factores físicos y geométricos en la clasificación estructural de la madera mediante técnicas no destructivas [The influence of physical and geometrical factors on timber stress-grading by non-destructive techniques]. Doctoral thesis. Universidad Politécnica de Madrid, ETSI Montes, Forestal y del Medio Natural. 412 p. DOI and pdf file: <https://doi.org/10.20868/UPM.thesis.43696>.
- Llana, D.F., Hermoso, E., Bobadilla, I., Íñiguez-González, G. (2018) Influence of moisture content on the results of penetration and withdrawal resistance measurements on softwoods. *Holzforschung* 72:549–555.
- Martínez, R.D. (2016) Métodos no destructivos de estimación de la densidad de madera. [Timber density estimation by non-destructive methods]. Doctoral thesis. Universidad de Santiago de Compostela, EPS de Lugo. 214 p. PDF file: <https://minerva.usc.es/xmlui/handle/10347/15159>.
- Martínez, R.D., Bobadilla, I. (2013) Extractor de muestras de madera mediante taladro [Wood sample extractor using a conventional drill]. Spain, ES2525504. (B27C 3/00) (2006.1), 16 Nov. 2015. Appl. 201330890, 14 July 2013.
- Martínez, R.D., Calvo, J., Arriaga, F., Bobadilla, I. (2018) In situ density estimation of timber pieces by drilling residue analysis. *Eur. J. Wood Prod.* 76:509–515.
- Montero, M.J. (2013) Clasificación de madera estructural de gran escuadría de *Pinus sylvestris* L. mediante métodos no destructivos [Grading of large cross section structural timber of *Pinus sylvestris* L. by non destructive techniques]. Doctoral thesis. Universidad Politécnica de Madrid, ETS de Ingenieros de Montes. 345 p. PDF file: <http://oa.upm.es/15201/>
- Montón, J. (2012) Clasificación estructural de la Madera de *Pinus radiata* D. Don procedente de Cataluña mediante métodos no destructivos y su aplicabilidad en la diagnosis estructural [Structural timber grading of *Pinus radiata* D. Don from Catalonia using NDT and applicability in structural assessment]. Doctoral thesis. Universidad Politécnica de Cataluña, Departamento de construcciones arquitectónicas I. 2 vol. 486 p. PDF: <http://www.tdx.cat/handle/10803/96423>.
- Morales-Conde, M.J., Rodríguez-Liñán, C., Saporiti-Machado, J. (2014) Predicting the density of structural timber members in service. The combine use of wood cores and drill resistance data. *Mater. Construcc.* 64:e029.
- Moreno-Chan, J., Raymond, C.A., Walker, J.C. (2010) Non-destructive assessment of green density and moisture condition in plantation-grown radiata pine (*Pinus radiata* D. Don.) by increment core measurements. *Holzforschung* 64:521–528.
- Morrell, J.J., Newbill, M.A., Freitag, C.M. (1994) Capacity of surface and internal groundline treatments to protect untreated Douglas-fir posts. *Holzforschung* 48:113–116.

- Paul, B.H., Baudendistel, M.E. (1943) A field method of determining specific gravity by use of increment cores or auger chips. Forest Products Laboratory, Madison, WI, USA. Republished in 1956 as Report No. 1587. 8 p.
- Ponneth, D., Vasu, A.E., Easwaran, J.C., Mohandass, A., Chauhan, S.S. (2014) Destructive and non-destructive evaluation of seven hardwoods and analysis of data correlation. *Holzforschung* 68:951–956.
- Pressler, M.R. (1866) Der forstliche Zuwachsbohrer [The forestry increment borer]. In: *Tharander Jahrbuch. Arnoldische Buchhandlung, Leipzig. Dritte Abtheilung III.* pp. 137–209.
- Rinn, F., Schweingruber, F.H., Schär, E. (1996) Resistograph and X-ray density charts of wood comparative evaluation of drill resistance profiles and X-ray density charts of different wood species. *Holzforschung* 50:303–311.
- Salamanca, M. (2017) Estimación mediante penetrómetros de la densidad en madera aserrada de las especies de coníferas y frondosas más habituales en construcción en España [Study of estimation by penetrometers of the density of sawn wood of the most commonly used coniferous and leafy species in construction in Spain]. Final Degree Project. Universidad Politécnica de Madrid, ETSI Montes, Forestal y del Medio Natural, Madrid, Spain. 205 p.
- Shalbafan, A., Luedtke, J., Welling, J., Fruehwald, A. (2013) Physio-mechanical properties of ultra-lightweight foam core particle-board: different core densities. *Holzforschung* 67:169–175.
- Soriano, J., Veiga, N.S., Martins, I.Z. (2015) Wood density estimation using the sclerometric method. *Eur. J. Wood Prod.* 73:756–758.
- Walters, C.S., Bruckmann, G. (1964) A comparison of methods for determining volume of increment cores. *J. Forest* 62:172–177.