

ID16- A NONLINEAR KINETIC ENERGY HARVESTER FOR LIGHT SURFACE OCEAN DRIFTERS

DANIEL M. TOMA¹³², MATIAS CARANDELL¹³³, MONTSERRAT CARBONELL-VENTURA¹³⁴, LLUIS VALS¹³⁵, JOAQUIN DEL RIO¹²⁹

Abstract

A nonlinear kinetic energy harvester for ocean drifter devices is presented. The design contains a gyroscopic wave energy harvesting system, capable of generating power from the wave-induced translational and rotational motions of a Wavy ocean drifter.

Keywords - energy harvesting; marine instruments.

The Wavy ocean drifters, as illustrated in Figure 1a., are basically small-size spheres with just enough room to accommodate power source, communications modules, antennae, sensors and data processor. The spherical shape of the proposed drifter allows it to re-float after stranding, while its optimized buoyancy reduces wind exposure to a minimum. However, the power supply of the Wavy drifters still relies on batteries, which exhibit several drawbacks such as low durability, difficulty of replacement, and most notably, inferior sustainability in terms of environmental impact. An alternative approach for replacing the battery in an ocean drifter involves harvesting kinetic energy from the ocean motion. Because of the very low and varying frequency, from 0.1Hz to 2Hz, harvesting this energy has an important hurdle. This study proposes a novel nonlinear energy harvester to supply low power oceanic drifters using an electromagnetic harvester. Therefore, this work presents a solution on how to gen-

erate power from low frequency driven electromagnetic energy harvester for an ocean drifter self-powered system. A prototype with a proposed electronic harvesting system is built and tested in a real medium

A general schematic of the device is shown in Figure 1b. The design is comprised of gyroscopic system, a gearing system to transform the oscillations to rotation, a flywheel, and a micro electromagnetic generator. As a result of the interaction with the waves, the float rotates with a pitching, roll and yaw motion. Moreover, the gyroscopic action provides a way to greatly enhance the ability of a mass to resist changes to its position which generates a torque along the axis that can be used to generate electrical power using the gearing system along with the flywheel and the micro electromagnetic generator. This structure has a proof mass oscillating in two orthogonal directions in-plane, one the sense direction and one the driven direction. Rotation about the out-of-plane axis couples these oscillations, allowing the sense rotation to be obtained.

ACKNOWLEDGMENTS

This work was supported by the project MELOA from the European Commission's Horizon 2020 research and Innovation program under Grant Agreement No. 776280

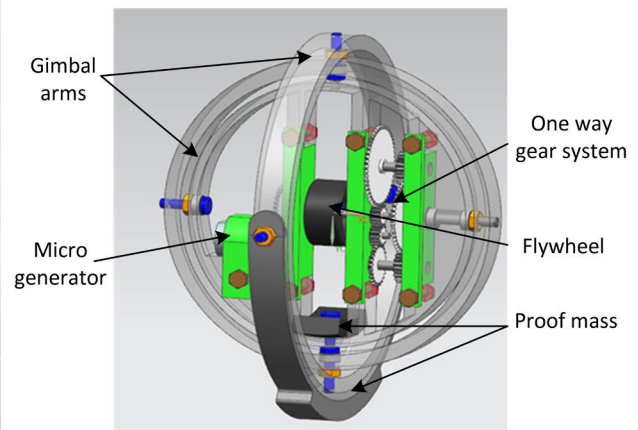

Figure 1 a) Wavy drifter b) Packaging view of the electromagnetic kinetic harvester