

Collective Unambiguous Positioning with High-Order BOC Signals

J. A. García-Molina, *Member, IEEE*, and J. A. Fernández-Rubio, *Senior Member, IEEE*

Abstract— The unambiguous estimation of high-order BOC signals in harsh propagation conditions is still an open problem in the literature. This paper proposes to overcome the limitations observed in state-of-the-art unambiguous estimation techniques based on the application of existing direct positioning techniques and the exploitation of the spatial diversity introduced by arrays of antennas. In particular, the ambiguity problem is solved as a multiple-input multiple-output (MIMO) estimation problem in the position domain.

Index Terms—High-order BOC, unambiguous positioning, collective estimation, direct positioning, MIMO-GNSS.

I. INTRODUCTION

The unambiguous estimation of high-order binary offset carrier (BOC) signals in harsh propagation conditions, typical of urban canyon scenarios, is still an open problem in the literature. The usage of BOC signals in new global navigation satellite systems (GNSS) enables the achievement of higher pseudorange accuracies than legacy BPSK signals, at the cost of new correlation peaks appearing in the autocorrelation function. Therefore, there is a certain risk that the receiver estimates, or locks onto, a side peak of the autocorrelation function instead of the main peak, resulting in a bias in the pseudorange estimation and, consequently, in the estimated receiver's position when this happens. The probability to estimate, or lock onto, the wrong correlation peak (i.e., to have a “false lock”, as referred to throughout the paper) can be in particular important when considering high-order BOC signals in harsh propagation conditions [1]. In this case, main and side correlation peaks can have very similar powers and be only few meters away from each other, making the unambiguous estimation challenging due to the low carrier-to-noise density ratio (C/N_0) conditions during fading periods.

The unambiguous estimation problem has been tackled in the literature with different families of techniques and processing approaches. Some of the techniques try to directly get rid of the ambiguity problem either by estimating and/or tracking the equivalent BPSK envelope of the BOC signal [2] (losing the higher accuracy provided by the original signal structure), or cancelling the side peaks via the application of un-matched filters [3], which in practice results in a loss in the signal-to-noise ratio (SNR) at post-correlation level [4]. Other techniques try to solve the ambiguity problem by identifying the main peak out of the multiple peaks present in the autocorrelation function, preserving the original accuracy of the BOC signal, but resulting in a

J. A. García-Molina is with the European Space Agency (ESA/ESTEC), 2201 AZ Noordwijk, The Netherlands. (e-mail: jose.antonio.garcia.molina@esa.int).

J. A. Fernández-Rubio is with the Department of Signal Theory and Communications, Universitat Politècnica de Catalunya (UPC), 08034 Barcelona, Spain. (e-mail: juan.a.fernandez@upc.edu).

risk of false lock. In this group, we can find techniques like the Bump Jumping [5], the Double Estimator [6], the Code-Subcarrier Smoothing [7], or the Astrium Correlator [8], among others. In general, these techniques are well suited for mild propagation conditions typical of open-sky scenarios, but start having limitations or become unstable in urban scenarios where low C/N_0 conditions (typically below around 30 dB-Hz) are experienced by the receiver [9]. Indeed, it is important to highlight that just additive white Gaussian noise (AWGN) channel conditions, without the need of additional multipath components, are enough to trigger the appearance of false locks given the structure of the high-order BOC signals [1], [10].

The unambiguous estimation problem has been also proposed to be solved using the LAMBDA method [11], tackling the problem as a carrier phase ambiguity one. In this case the ambiguity is solved at position level based on the code and subcarrier observables previously estimated for all the BOC signals being tracked. This approach has shown a higher robustness than other subcarrier-based tracking methods operating at pseudorange level when operating in the presence of multipath in nominal C/N_0 conditions [11].

Longer coherent and non-coherent integration periods can be considered in order to increase the SNR observed by the estimators (reducing the probability of false lock) as proposed in techniques like the Double-Optimization Multi-correlator-based Estimator (DOME) [1], [12]. Nevertheless, the maximum integration periods that can be applied in practice are limited by receiver, user and environment constraints [13]-[15], such that for low C/N_0 conditions the equivalent SNR observed by the estimator remains also low and the probability of false lock is still important [1], [10].

This paper proposes to overcome the limitations observed in state-of-the-art unambiguous estimation techniques by introducing an additional processing gain in the unambiguous estimation problem in two spatial dimensions. The first dimension is the spatial transmission diversity introduced by the multiple GNSS satellites in view to the receiver. The second dimension is the spatial reception diversity introduced when the receiver features an array of antennas. These two spatial dimensions, and the corresponding spatial processing gains, are proposed to be efficiently exploited in the receiver's position domain, tackling the unambiguous estimation problem at position level instead of at pseudorange level. Working directly in the position domain (collectively exploiting multiple satellites' signals) has shown advantages in the detection and estimation of legacy GNSS signals in terms of sensitivity at low SNR conditions [16]-[29], at the cost of a very high complexity of the resulting solution. Nevertheless, the unambiguous positioning problem can be considered as a fine estimation problem in which an *a priori* coarse position solution has been already estimated by the receiver (which can be derived based on e.g., the potentially ambiguous pseudoranges estimated with any conventional tracking technique, or the noisier pseudoranges estimated via the tracking of the BPSK envelope of the BOC signals [2]). Therefore, in practice, the range of positions of interest in the unambiguous positioning problem discussed herein is bounded. This is drastically reducing the complexity of the implementation with respect to the so-called direct positioning and collective detection techniques [16]-[29] since the solution can be based on state-of-the-art receiver

architectures.

The main motivation of the paper is to efficiently exploit the proposed spatial dimensions for enabling the robust unambiguous positioning with high-order BOC signals in the presence of deep fading and at very low SNR conditions (per satellite's signal) for which state-of-the-art single-satellite unambiguous estimation techniques are already unstable. In the case of the single-antenna receiver configuration, this is achieved by treating the unambiguous estimation of the receiver's position as a multiple-input single-output (MISO) estimation problem in which the multiple transmitted high-order BOC signals are jointly exploited (i.e., a collective unambiguous estimation is to be performed). And when an array of antennas is featured by the receiver, this is achieved by jointly exploiting both transmission and reception diversities in the resulting multiple-input multiple-output (MIMO) GNSS system.

For both MISO- and MIMO-GNSS systems, the maximum likelihood estimator (MLE) of the receiver's position is used as baseline in the proposed solutions. In both cases, the signal model used in the derivation of the solution is defined such that the focus is kept on efficiently improving the equivalent SNR conditions observed by the estimator, while mitigating the multipath impact taking advantage of the spatial diversities available. In the particular case of the MIMO-GNSS system, a generalist unstructured array signal model not relying on the typical narrowband array assumption used in the GNSS literature [30]-[33] is considered due to the structure of the high-order BOC signals. The proposed array signal model will additionally allow to keep the problem open to the eventual exploitation of unknown spatial GNSS signal structures with directions of arrival different to those of the expected line-of-sight (LOS) signals. It is to be noticed that this can be of high interest (and a need) in urban canyon conditions, where only highly attenuated refracted, diffracted and/or reflected multipath components (i.e., non-LOS components) might be received [13], [34], [35]. Therefore, the proposed approach differs from the typical application of arrays of antennas in the GNSS literature [30]-[33], where the LOS signal is considered to be always available and the spatial reception diversity is exploited to get rid of multipath components and/or interferences disturbing the estimation of the LOS signal.

The novelty of this paper is twofold. On the one hand, the unambiguous estimation of high-order BOC signals is proposed to be solved via the joint exploitation of both reception and transmission diversities, tackling the ambiguity problem as a MIMO estimation problem in the position domain. This approach allows to achieve a more robust ambiguity resolution than with state-of-the-art single-satellite-based unambiguous estimation techniques. On the other hand, the unambiguous positioning problem is treated as a fine positioning problem in which an *a priori* coarse position solution (potentially biased) is available. This enables the optimized implementation of the proposed estimators (for both single- and multiple-antenna configurations) based on multi-correlator architectures and state-of-the-art acquisition, tracking and positioning engines (i.e., the application of collective detection and acquisition techniques is not strictly required).

The paper is organized as follows. The unambiguous estimation problem in the position domain is first discussed in section II,

where the MISO signal model for the single-antenna configuration is presented, and the ML-based solution is derived. Then, section III extends the problem to the multiple-antenna configuration, presenting the signal model for the MIMO-GNSS system and the resulting ML-based solution when considering a generalist unstructured array model. Simulation results are then presented for both configurations in Section IV, showing the benefits provided with respect to the single-satellite-based unambiguous estimation approach. Finally, the conclusions are presented in section V.

In terms of the notation used throughout the paper, vectors and matrices are denoted by lower case and upper case bold letters, respectively. The superscripts T and H denote the transpose and Hermitian transpose operations, respectively. $\mathbb{R}^{N \times M}$ and $\mathbb{C}^{N \times M}$ denote the set of $N \times M$ matrices with real and complex entries, respectively. \hat{x} denotes the estimation of the parameter x . $\|\mathbf{x}\|$ denotes the ℓ^2 -norm of vector \mathbf{x} , such that $\|\mathbf{x}\|^2 = \mathbf{x}^H \mathbf{x}$. \mathbf{I} denotes the identity matrix. $\mathcal{CN}(\boldsymbol{\mu}, \boldsymbol{\Sigma})$ denotes a complex multivariate Gaussian distribution with mean $\boldsymbol{\mu}$ and covariance matrix $\boldsymbol{\Sigma}$. sgn denotes the sign function. $\arg \max_x f(x)$ denotes the values of x that maximizes the function $f(x)$.

II. UNAMBIGUOUS POSITIONING WITH HIGH-ORDER BOC SIGNALS FOR SINGLE-ANTENNA RECEIVERS

A. System and signal model

Let us consider a system consisting of M GNSS satellites, each of them transmitting a high-order BOC signal at a given frequency band with a pseudorandom code orthogonal to the other satellites. The M BOC signals are then received by a GNSS receiver equipped with a single antenna. It is considered that a coarse estimation of the receiver's position has been already performed by the receiver without unambiguously exploiting the accuracy of the high-order BOC signals. Moreover, it is considered that other parameters needed in practice for the derivation of the fine receiver's position solution (like the GNSS satellites' navigation data or the receiver's clock bias, just to mention some) are known or estimated by other means by the GNSS receiver. The target now is to perform a fine estimation of the receiver's position by fully exploiting, in an unambiguous way, the accuracy of the high-order BOC signals received.

In general, in urban propagation conditions the complex baseband signal received by the GNSS antenna from the M GNSS satellites in view can be modeled as

$$\begin{aligned}
 x_{MP}(t) &= \sum_{i=1}^M a_{i,0}(t) d_i(t - \tau_{i,0}(t)) \exp\{j2\pi f_{i,0}(t)t\} \\
 &+ \sum_{i=1}^M \sum_{l=1}^{L_i-1} a_{i,l}(t) d_i(t - \tau_{i,l}(t)) \exp\{j2\pi f_{i,l}(t)t\} + n(t),
 \end{aligned} \tag{1}$$

where one LOS signal and $L_i - 1$ multipath rays for the i -th satellite are considered, $a_{i,l}$, $\tau_{i,l}$ and $f_{i,l}$ are the complex amplitude, time-delay and frequency-shift for the l -th signal propagation ray (with $l=0$ for the LOS signal) of the i -th satellite, respectively, and n is the noise component, which is modeled as a complex, circularly-symmetric, zero-mean and temporally-white Gaussian process. The Doppler effect is considered to be modeled not only in the frequency-shift, but also in the time-delay for each signal propagation ray. d_i is the complex baseband model of the BOC-modulated direct-sequence spread-spectrum signal transmitted by the i -th GNSS satellite, which can be modeled as [36]

$$d_i(t) = g_i(t) \text{sgn}\{\sin(2\pi f_{sc}t + \varphi)\}, \quad (2)$$

where $g_i(t)$ is the pseudorandom code for the i -th satellite, which is known *a priori* by the receiver, f_{sc} is the so-called subcarrier frequency of the BOC signal, and φ is the phase angle typically used to define if the BOC signal is sine phased ($\varphi = 0$) or cosine phased ($\varphi = \pi/2$). It is to be noticed that the complex amplitudes $a_{i,l}$ model both the changes introduced by the data modulated onto the BOC signal and any complex amplitude change introduced by the propagation channel for each of the propagation rays.

In the following, the multipath components appearing in reality in harsh propagation conditions typical of urban scenarios are not considered in the signal model used as baseline for the derivation of the proposed unambiguous position estimator. The reason is twofold. On the one hand, the joint exploitation of the received signals in the unambiguous estimation of the receiver's position (taking advantage of the different satellites' propagation conditions and geometries), is not only a way to improve the SNR conditions observed by the estimator, but also an effective approach to mitigate the impact of multipath on the ambiguity resolution, as will be shown later on in the paper. Thus, multipath mitigation can be achieved without the need of estimating the multipath components (as shown for legacy GNSS signals in [17]), which would additionally increase the complexity of the estimator. And, on the other hand, in realistic propagation conditions it is difficult to estimate those multipath components. Indeed, in practice the received multipath components are typically buried in noise, it is difficult to model them with a set of specular rays, and their properties (in terms of delay and complex amplitude) are changing continuously in time as fast as the environment surrounding the user does.

Based on the previous considerations, the complex baseband signal received by the GNSS antenna is modeled based on the LOS contributions of the M GNSS satellites in view as

$$x(t) = \sum_{i=1}^M a_i(t) d_i(t - \tau_i(t)) \exp\{j2\pi f_i(t)t\} + n(t), \quad (3)$$

where the 0 -th sub-index used in equation (1) for the LOS signals is omitted for simplicity (i.e., $a_i \triangleq a_{i,0}$, $\tau_i \triangleq \tau_{i,0}$ and $f_i \triangleq f_{i,0}$). The time-delay $\tau_i(t)$ and frequency-shift $f_i(t)$ parameters observed by the receiver for each satellite at time t are dependent on the receiver position, such that $\tau_i(t) \triangleq \tau_i(t, \mathbf{p})$ and $f_i(t) \triangleq f_i(t, \mathbf{p})$, with $\mathbf{p} \triangleq \mathbf{p}(t) \in \mathbb{R}^{3 \times 1}$ the position vector in the ECEF coordinate system at time t . This trivial fact can be exploited to derive the receiver's position directly in the position domain, as already proposed in the literature for legacy signals [16]-[29], or, equivalently, for solving the unambiguous estimation problem in the position domain when using high-order BOC signals. Based on this dependence and equation (3), we can define a basis function b_i for the i -th satellite as

$$b_i(t, \mathbf{p}) = d_i(t - \tau_i(t, \mathbf{p})) \exp\{j2\pi f_i(t, \mathbf{p})t\}, \quad (4)$$

where the dependence of the position vector \mathbf{p} with the time is omitted for simplicity. Let us consider now the vector $\mathbf{x} = [x(t_0) \dots x(t_{0+K-1})]^T \in \mathbb{C}^{K \times 1}$ containing a snapshot of K samples of the signal received by the GNSS antenna with sampling period $T_s = t_K - t_{K-1}$. Assuming that a_i , τ_i and f_i parameters are constant during the observation time $T_s K$ (being therefore the position \mathbf{p} considered constant during the observation time), the vector \mathbf{x} can be defined as

$$\mathbf{x} = \mathbf{B}(\mathbf{p})\mathbf{a} + \mathbf{n}, \quad (5)$$

where $\mathbf{a} = [a_1 \dots a_M]^T \in \mathbb{C}^{M \times 1}$ gathers the complex amplitudes for the M LOS contributions, $\mathbf{n} \in \mathbb{C}^{K \times 1}$ is the complex noise vector (with $\mathbf{n} \sim \mathcal{CN}(\mathbf{0}, \sigma^2 \mathbf{I})$), and $\mathbf{B}(\mathbf{p}) = [\mathbf{b}_1(\mathbf{p}) \dots \mathbf{b}_M(\mathbf{p})] \in \mathbb{C}^{K \times M}$ is the basis function matrix, which is composed by the basis function vectors for each satellite $\mathbf{b}_i = [b_i(t_0, \mathbf{p}) \dots b_i(t_{0+K-1}, \mathbf{p})]^T \in \mathbb{C}^{K \times 1}$.

B. Unambiguous ML-based position estimator

Based on the signal model defined in equation (5), the MLE of the position can be obtained by minimizing the cost function [37]

$$\Lambda_1(\mathbf{p}, \mathbf{a}) = \|\mathbf{x} - \mathbf{B}(\mathbf{p})\mathbf{a}\|^2. \quad (6)$$

In the following, an *a priori* coarse position estimation $\hat{\mathbf{p}}_c$ is considered in the optimization problem, which will drastically simplify in practice the implementation of the proposed ML-based solution. Exploiting this *a priori* coarse position, we can define the unambiguous positioning problem as the ML-based optimization problem

$$\begin{aligned} \hat{\mathbf{p}}, \hat{\mathbf{a}} &= \arg \min_{\mathbf{p}, \mathbf{a}} \Lambda_1(\mathbf{p}, \mathbf{a}) \\ \text{subject to } &\|\mathbf{p} - \hat{\mathbf{p}}_c\| < \alpha, \end{aligned} \quad (7)$$

where α defines the search area around the coarse position estimation. In order to derive the ML-based solution at post-correlation level, let us define the correlations $\hat{\mathbf{r}}_{xx} = \mathbf{x}^H \mathbf{x}$, $\hat{\mathbf{r}}_{xb}(\mathbf{p}) = \mathbf{B}^H(\mathbf{p}) \mathbf{x}$, and $\hat{\mathbf{R}}_{bb}(\mathbf{p}) = \mathbf{B}^H(\mathbf{p}) \mathbf{B}(\mathbf{p})$. Based on these definitions, the vector of complex amplitudes \mathbf{a} minimizing Λ_1 corresponds to the well-known least squares estimator [37]

$$\hat{\mathbf{a}} = \hat{\mathbf{R}}_{bb}^{-1}(\mathbf{p}) \hat{\mathbf{r}}_{xb}(\mathbf{p}). \quad (8)$$

Substituting now equation (8) into equation (6), a cost function only dependent on \mathbf{p} is obtained,

$$\Lambda_2(\mathbf{p}) = \hat{\mathbf{r}}_{xx} - \hat{\mathbf{r}}_{xb}^H(\mathbf{p}) \hat{\mathbf{R}}_{bb}^{-1}(\mathbf{p}) \hat{\mathbf{r}}_{xb}(\mathbf{p}), \quad (9)$$

which is equivalent to the cost function exploited in the direct position solution for legacy GNSS signals [17]. Therefore, the unambiguous ML-based estimator of the position can be defined as

$$\begin{aligned} \hat{\mathbf{p}} = \arg \max_{\mathbf{p}} \{ & \hat{\mathbf{r}}_{xb}^H(\mathbf{p}) \hat{\mathbf{R}}_{bb}^{-1}(\mathbf{p}) \hat{\mathbf{r}}_{xb}(\mathbf{p}) \} \\ & \text{subject to } \|\mathbf{p} - \hat{\mathbf{p}}_c\| < \alpha. \end{aligned} \quad (10)$$

Fig. 1 shows an example of the cost function to be maximized in equation (10) (shown for illustrative purposes only with respect to the horizontal position plane) when considering the transmission of a $\text{BOC}_{\cos}(15, 2.5)$ signal [36] by eleven satellites in view by the receiver at good SNR conditions, and with an horizontal dilution of precision (HDOP) equal to one. As can be observed in this example, the multiple correlation peaks of the $\text{BOC}_{\cos}(15, 2.5)$ signals (shown for completeness in Fig. 2) induce the appearance of multiple peaks also in the position domain. In particular, the maximum at the $[0,0]$ position corresponds to the actual position of the receiver, while the rest of local peaks (i.e., “false” position peaks) correspond to the contributions of the side peaks in the horizontal position plane.

In case low SNR conditions are observed for the signals of all or most of the satellites in view, it might be challenging to unambiguously derive the receiver’s position for high-order BOC signals, even when considering the exploitation of the transmission diversity in the position domain, as proposed herein, resulting in biased position solutions with a non-negligible probability. In this situation, different alternatives might be followed. One possibility is to derive only a coarse position estimation based on the BPSK envelopes of the high-order BOC signals in view, losing the higher accuracy provided by the BOC signals, but avoiding the ambiguity problem. Another option is to filter the obtained position solutions in the time domain (e.g., applying a Kalman filter or other filtering approaches) such that the biased positions (i.e., the outliers in the position domain) are filtered out. This solution might be applicable at SNR conditions for which the probability to derive biased positions is still relatively low. For worse conditions, we can also consider the non-coherent integration (or other integration approaches)

of Q consecutive signal snapshots in order to increase the equivalent SNR conditions under which the position estimator will operate. Last, but not least, we could consider the exploitation of an array of antennas in order to introduce an additional processing gain, as will be proposed later on in the paper.

C. Implementation of the unambiguous ML-based solution

The non-linear optimization problem in equation (10) is bounded by the constraint imposed, limiting the search space around the *a priori* coarse position solution available by the receiver before the fine unambiguous position estimation is performed. Taking into account that the error of the coarse position can be in practice in the order of several meters or few tens of meters (being α in equation (10) defined accordingly), and that the optimization problem is non-convex (as shown in the example of Fig. 1), the direct application of a grid search approach [37] is considered feasible and of interest. The resolution of the grid should be enough to detect unambiguously the maximum of the cost function corresponding to the actual receiver's position (typically, sub-meter grid resolution might be needed).

In case a multi-correlator architecture is considered by the receiver (i.e., a partial or complete sampling, with enough resolution, of the cross-correlation function for each of the satellites in view is already estimated by the receiver), the cross-correlation samples $\hat{\mathbf{r}}_{xb}$ for each evaluated position \mathbf{p} in the grid search (as per equation (10)) can be derived from the available multi-correlation samples. Let us assume that in this case the “prompt” correlation sample (derived from the so-called prompt correlator [36]) for all the satellites in view is driven by the *a priori* coarse position estimation $\hat{\mathbf{p}}_c$ (which is just a possible implementation case). Additionally, let us consider that each sampled cross-correlation function is interpolated in order to derive a continuous version of the estimated cross-correlation function $\hat{r}_i(\delta)$, with $\hat{r}_i(0)$ corresponding to the prompt correlation sample for the i -th satellite. Based on this, the cross-correlation samples in $\hat{\mathbf{r}}_{xb}(\mathbf{p})$ can be derived as

$$\hat{\mathbf{r}}_{xb}(\mathbf{p}) = [\hat{r}_1(\delta_1) \dots \hat{r}_M(\delta_M)]^T \in \mathbb{C}^{M \times 1}, \quad (11)$$

where $\delta_i \triangleq \delta_i(\mathbf{p}, \hat{\mathbf{p}}_c)$ is the expected difference in the i -th satellite's pseudorange introduced by the change in position from the coarse position estimation $\hat{\mathbf{p}}_c$ to the evaluated position \mathbf{p} . This makes the proposed approach fully compatible with state-of-the-art multi-correlator receiver architectures and single-satellite-based acquisition and tracking engines. The resulting unambiguous GNSS receiver can be based on the high-level architecture depicted in Fig. 3.

Finally, in case the optimization problem needs to be further simplified because of implementation reasons, the derivation of the cost function in equation (10) can be simplified by approximating $\hat{\mathbf{R}}_{bb}(\mathbf{p})$ as an identity matrix when the cross-correlations between the direct-sequence spread-spectrum signals d_i of the different GNSS satellites can be considered approximately null (as

typically considered in collective detection and positioning techniques [19]-[29]).

D. Comparison with relevant state-of-the-art techniques

In terms of performance, the main advantage of the proposed single-antenna unambiguous position estimator with respect to the unambiguous state-of-the-art techniques operating at pseudorange level is the higher robustness solving the ambiguity problem at low C/No conditions and in the presence of severe multipath, as will be shown in Section IV. In terms of computational complexity, the proposed approach requires a higher number of correlators per tracked signal (in the order of tens or hundreds, depending on the BOC signal being considered) than state-of-the-art unambiguous techniques, where typically five correlators are used to solve the ambiguity. Nevertheless, it is to be noticed that multi-correlator architectures are nowadays broadly used in mass-market receivers, in particular when targeting the operation in harsh propagation conditions, so their real-time implementation is not considered a problem. On the other hand, the computational burden of solving the unambiguous optimization problem in equation (10) based on the output of the multiple correlators is considerably higher than that of the discriminators used in state-of-the-art single-satellite-based unambiguous tracking techniques. Taking into account that the proposed unambiguous position estimator can be applied in parallel to a conventional positioning engine, as proposed in the block diagram depicted in Fig. 3, the solution of equation (10) can be derived with a lower rate (typically, down to 1 Hz) than the update rate of the single-satellite tracking loops, such that the computational burden can be adjusted in order to allow the real-time implementation in conventional receiver architectures.

Comparing now the proposed unambiguous estimator to direct positioning and collective detection and acquisition techniques applied to legacy signals [16]-[29], it is to be noticed that the main target herein is not to allow the exploitation of signals that otherwise could not be acquired or tracked (as achieved with the application of collective acquisition techniques), but to solve in a robust way the ambiguity problem appearing when tracking high-order BOC signals. This allows the application of the proposed unambiguous estimator based on conventional acquisition, tracking and positioning engines, relying directly on the output of the correlators and a potentially ambiguous position solution, as shown in Fig. 3. In this way, the computational burden of the overall receiver can be reduced with respect to conventional direct positioning and collective techniques, at the cost of not achieving an improved acquisition and tracking sensitivity. In case the target would be not only to achieve a robust unambiguous position estimation, but also to improve the receiver's sensitivity with respect to state-of-the-art single-satellite-based techniques, efficient collective detection and positioning implementations could be exploited in parallel to the proposed unambiguous estimator (see e.g., [23], [25], [28], [29]).

Last but not least, it is worth to briefly compare the single-antenna unambiguous position estimator to the LAMBDA-based method proposed in [11]. Both techniques solve the ambiguity problem in the position domain. The main difference is that while the estimator proposed herein exploits directly the complex samples obtained from the multiple correlators for each BOC signal

being tracked, the LAMBDA-based method exploits the code and sub-carrier measurements previously estimated for each of the BOC signals (i.e., an estimation process has been already applied for each BOC signal before solving the ambiguity in the position domain). The direct exploitation of the output of the correlators (i.e., the sampled correlation functions for each BOC signal being tracked) is expected to provide the optimum performance in terms of ambiguity resolution. Indeed, this will allow to solve the ambiguity problem even when most of the BOC signals being tracked are highly affected by low C/No conditions and severe multipath, as will be shown in Section IV. Moreover, this approach will allow the full exploitation of the spatial reception diversity in the multi-antenna configuration discussed in Section III.

III. UNAMBIGUOUS POSITIONING WITH HIGH-ORDER BOC SIGNALS IN THE MIMO-GNSS FRAMEWORK

A. System and signal model

Let us consider the same system model used in section II, but exploiting now an array of N antennas in the GNSS receiver, as depicted in Fig. 4. In this array of antennas, the distribution of the antennas is arbitrary, and the relative position of each of the antennas with respect to the receiver phase center is *a priori* known by the receiver and does not change with time. Therefore, the position \mathbf{p}_j for each antenna can be defined based on the position \mathbf{p}_0 of the receiver phase center, i.e., $\mathbf{p}_j = \mathbf{p}_0 - \Delta\mathbf{p}_j$, being \mathbf{p}_0 the position to be unambiguously estimated in this case. Moreover, all the signals received by the N antennas are considered to be referenced to the same receiver clock. As for the single-antenna case, it is assumed that the receiver has already performed a coarse estimation of the receiver's position without unambiguously exploiting the accuracy of the high-order BOC signals. Thus, the target herein is to perform a fine estimation of the receiver's phase center position by fully exploiting, in an unambiguous way, the accuracy of the high-order BOC signals received with the array of antennas and jointly exploiting both transmission and reception diversities.

In order to build now the complete signal model for the N receiver's antennas with an arbitrary distribution, a generalist unstructured antenna array model is considered, not relying on the typical narrowband array assumption exploited in the GNSS literature [30]-[33], and with an arbitrary structure of the complex amplitudes of the MN LOS signal contributions received. The narrowband array model is proposed not to be applied herein given the high accuracy provided by the high-order BOC signals, which is in the order of few cm for nominal C/No conditions [1] (i.e., in the order, or below, the distance between the receiver's antennas). Thus, modeling the propagation delays between the receiver's antennas as phase shifts is not realistic, and could result in additional biases in the estimation of the high-order BOC signals. Therefore, the different propagation delays on the received high-order BOC signals for each antenna need to be modeled. On the other hand, the unstructured array model is an interesting and desired feature for several reasons. First of all, this model is beneficial in order for the proposed solution to be independent

of the quality of the phase calibration of the array of antennas, being applicable to un-calibrated arrays and/or low-end array solutions. Moreover, this makes the solution also independent of the phases of the transmitted signals, so it can be applied when unknown data is modulated on the BOC signals. And last, but not least, this will make the resulting array estimator robust to additional phase distortions introduced by the propagation channel.

Temporally and spatially white Gaussian noise is considered in the array signal model. Therefore, the noise component is not meant to model unknown spatial signal structures created by multipath and/or interference sources, as typically considered in the GNSS literature [30]-[33] (where the LOS signals are assumed to be always available and the spatially colored noise is filtered out to mitigate the impact of those multipath and/or interference sources). The presence of the LOS signal components in harsh propagation conditions typical of urban environments is not always ensured due to the blockage and shadowing effects. So, trying to spatially filter out the non-LOS multipath signals received with directions of arrival different to those of the originally expected LOS signals, might not be necessarily beneficial in this type of environment. Indeed, those non-LOS signal components might be needed to be exploited for enabling the derivation of an unambiguous position solution in the absence of most or all of the LOS signal components. Therefore, instead of mitigating the impact of multipath on the ambiguity resolution by filtering out the spatially colored noise components (which would additionally increase the computational burden of the estimator), it is proposed to do so by jointly exploiting the different satellites' propagation geometries together with the spatial propagation diversity provided by the array of antennas (being the multipath mitigation efficiently achieved without the need of modeling or estimating the multipath components, as will be shown later on in the paper).

Based on the previous considerations, the complex baseband signal received by the j -th GNSS antenna from the LOS contributions of the M GNSS satellites in view is modeled as

$$x_j(t) = \sum_{i=1}^M a_{i,j}(t) d_i(t - \tau_{i,j}(t)) \exp\{j2\pi f_{i,j}(t)t\} + n_j(t), \quad (12)$$

where $a_{i,j}$, $\tau_{i,j}$ and $f_{i,j}$ are the complex amplitude, the time-delay and the frequency-shift of the BOC signal from the i -th satellite received by the j -th antenna, respectively, and n_j is the complex noise observed by the j -th antenna. Following the same approach used for the single-antenna case in equations (4) and (5), we can define the vector $\mathbf{x}_j = [x_j(t_0) \dots x_j(t_{K-1})]^T \in \mathbb{C}^{K \times 1}$ containing a signal snapshot of K samples received by the j -th antenna, which is modeled as $\mathbf{x}_j = \mathbf{B}(\mathbf{p}_j)\mathbf{a}_j + \mathbf{n}_j$, with $\mathbf{B}(\mathbf{p}_j)$ the basis function matrix for the j -th antenna.

Since the narrowband antenna array model cannot be considered herein, as mentioned earlier, the different propagation delays on the high-order BOC signals for each antenna need to be modeled. Thus, a basis function $\mathbf{B}(\mathbf{p}_j)$ for each antenna needs to be

considered in the signal model. Exploiting now the temporally and spatially white Gaussian noise assumption, we can simplify the array model representation by defining a multi-antenna basis function matrix $\mathbf{S}(\mathbf{p}_0)$ based on the single-antenna basis function matrices $\mathbf{B}(\mathbf{p}_j) \triangleq \mathbf{B}(\mathbf{p}_0 - \Delta\mathbf{p}_j)$ as

$$\mathbf{S}(\mathbf{p}_0) = \begin{bmatrix} \mathbf{B}(\mathbf{p}_0 - \Delta\mathbf{p}_1) & \mathbf{0} & \dots & \mathbf{0} \\ \mathbf{0} & \mathbf{B}(\mathbf{p}_0 - \Delta\mathbf{p}_2) & \dots & \mathbf{0} \\ \vdots & \vdots & \ddots & \vdots \\ \mathbf{0} & \mathbf{0} & \dots & \mathbf{B}(\mathbf{p}_0 - \Delta\mathbf{p}_N) \end{bmatrix}, \quad (13)$$

such that the signal snapshots observed by the N antennas can be gathered in the vector $\mathbf{y} = [\mathbf{x}_1^T \dots \mathbf{x}_N^T]^T \in \mathbb{C}^{NK \times 1}$, which can be then modeled as

$$\mathbf{y} = \mathbf{S}(\mathbf{p}_0)\mathbf{c} + \mathbf{e}, \quad (14)$$

with the vector $\mathbf{c} = [\mathbf{a}_1^T \dots \mathbf{a}_N^T]^T \in \mathbb{C}^{MN \times 1}$ containing all the complex amplitudes of the expected MN LOS contributions, and $\mathbf{e} = [\mathbf{n}_1^T \dots \mathbf{n}_N^T]^T \in \mathbb{C}^{NK \times 1}$ gathering the noise components of the N antennas, being the noise considered to be normalized between antennas, with $\mathbf{e} \sim \mathcal{CN}(\mathbf{0}, \sigma^2 \mathbf{I})$, and therefore $\mathbf{y} \sim \mathcal{CN}(\mathbf{S}(\mathbf{p}_0)\mathbf{c}, \sigma^2 \mathbf{I})$. It is to be noticed that the signal model in equation (14) differs from the typical matrixial representation of a MIMO signal model based on a MIMO channel matrix (i.e., typically the MIMO channel matrix is defined as $\mathbf{H} = [\mathbf{a}_1 \dots \mathbf{a}_N] \in \mathbb{C}^{M \times N}$). Nevertheless, the representation used simplifies the later derivation of the proposed ML-based estimator and is in line with the assumptions considered.

B. Unambiguous ML-based position estimator in the MIMO-GNSS framework

Based on the signal model defined in equation (14), the MLE of the receiver's phase center position can be obtained by minimizing the cost function

$$\Lambda_3(\mathbf{p}_0, \mathbf{c}) = \|\mathbf{y} - \mathbf{S}(\mathbf{p}_0)\mathbf{c}\|^2. \quad (15)$$

Exploiting now the vector of complex amplitudes \mathbf{c} minimizing Λ_3 , which corresponds to the least squares estimator

$$\hat{\mathbf{c}} = \hat{\mathbf{R}}_{ss}^{-1}(\mathbf{p}_0)\hat{\mathbf{r}}_{ys}(\mathbf{p}_0), \quad (16)$$

where $\hat{\mathbf{r}}_{ys}(\mathbf{p}_0) = \mathbf{S}^H(\mathbf{p}_0)\mathbf{y}$ and $\hat{\mathbf{R}}_{ss}(\mathbf{p}_0) = \mathbf{S}^H(\mathbf{p}_0)\mathbf{S}(\mathbf{p}_0)$, it can be shown that the minimization of the cost function in equation (15) is equivalent to maximizing the cost function

$$\Lambda_4(\mathbf{p}_0) = \sum_{j=1}^N \hat{\mathbf{r}}_{x_{jb}}^H(\mathbf{p}_0 - \Delta\mathbf{p}_j) \hat{\mathbf{R}}_{bb}^{-1}(\mathbf{p}_0 - \Delta\mathbf{p}_j) \hat{\mathbf{r}}_{x_{jb}}(\mathbf{p}_0 - \Delta\mathbf{p}_j), \quad (17)$$

where the cross-correlations for each of the receiver's antennas are defined as $\hat{\mathbf{r}}_{x_{jb}}(\mathbf{p}_0 - \Delta\mathbf{p}_j) \triangleq \hat{\mathbf{r}}_{x_{jb}}(\mathbf{p}_j) = \mathbf{B}^H(\mathbf{p}_0 - \Delta\mathbf{p}_j)\mathbf{x}_j$, and $\hat{\mathbf{R}}_{bb}(\mathbf{p}_0 - \Delta\mathbf{p}_j) \triangleq \hat{\mathbf{R}}_{bb}(\mathbf{p}_j) = \mathbf{B}^H(\mathbf{p}_0 - \Delta\mathbf{p}_j)\mathbf{B}(\mathbf{p}_0 - \Delta\mathbf{p}_j)$. Considering now the availability of an *a priori* coarse position estimation $\hat{\mathbf{p}}_c$, we can define the unambiguous positioning problem as the ML-based optimization problem

$$\begin{aligned} \hat{\mathbf{p}}_0 &= \arg \max_{\mathbf{p}_0} \Lambda_4(\mathbf{p}_0) \\ &\text{subject to } \|\mathbf{p}_0 - \hat{\mathbf{p}}_c\| < \alpha, \end{aligned} \quad (18)$$

where α is defined as for the single-antenna case in equation (7).

C. Implementation of the unambiguous ML-based solution in the MIMO-GNSS configuration

The non-linear optimization problem subject to a constraint in equation (18) can be solved via the direct application of a grid search approach, given the bounded search space in the position domain. Moreover, considering the implementation of a multi-correlator architecture by the receiver for each of the receiver's antennas (with all the correlators driven by $\hat{\mathbf{p}}_c$), the cross-correlation samples $\hat{\mathbf{r}}_{x_{jb}}(\mathbf{p}_0 - \Delta\mathbf{p}_j)$ for each evaluated position \mathbf{p}_0 can be derived from the available multi-correlation samples, as in equation (11) for the single-antenna configuration, but in this case accounting for the relative position of each of the antennas with respect to the receiver's phase center, i.e.,

$$\hat{\mathbf{r}}_{x_{jb}}(\mathbf{p}_0 - \Delta\mathbf{p}_j) = [\hat{r}_{1,j}(\delta_{1,j}) \dots \hat{r}_{M,j}(\delta_{M,j})]^T, \quad (19)$$

with $\hat{r}_{i,j}(\delta)$ the continuous interpolated version of the estimated cross-correlation function for the i -th satellite and j -th antenna, and $\delta_{i,j} \triangleq \delta_{i,j}(\mathbf{p}_0, \hat{\mathbf{p}}_c)$ the expected pseudorange difference for the i -th satellite and j -th antenna introduced by the change in position from the coarse position estimation $\hat{\mathbf{p}}_c$ to $\mathbf{p}_0 - \Delta\mathbf{p}_j$, with \mathbf{p}_0 the current evaluated position. The resulting multi-antenna unambiguous GNSS receiver can be based on the high-level architecture depicted in Fig. 5.

IV. SIMULATION RESULTS

A. Simulated scenarios

The unambiguous positioning with high-order BOC signals based on the ML-based estimators in the position domain proposed for a single-antenna receiver (in a MISO system configuration) and for a receiver featuring an array of antennas (in a MIMO system configuration) have been simulated via a semi-analytical approach at post-correlation level when considering $\text{BOC}_{\cos}(15, 2.5)$ signals being transmitted by the GNSS satellites. In order to focus on the BOC ambiguity resolution problem at low SNR conditions (which is already a very challenging task), other effects that could degrade further the ability of the receiver to identify unambiguously the main correlation peak are not considered herein since can be tackled by other means as part of the GNSS receiver front-end design (e.g., the application of non-linear phase filters in the receiver front-end highly distorting the cross-correlation function of the BOC signal, or eventual under-sampling or quantization issues impacting the recovery of the original BOC autocorrelation function [1],[7]). Therefore, it is considered that, for high SNR conditions (where the noise impact is negligible) and in the absence of multipath, the receiver should be able to recover perfectly a symmetric filtered version of the autocorrelation function. A bandwidth of 40 MHz is used, allowing the reception of the two main frequency lobes of the $\text{BOC}_{\cos}(15, 2.5)$ signal.

The usage of $\text{BOC}_{\cos}(15, 2.5)$ signals is considered herein as a representative case of high-order BOC signal. The probability of false lock (i.e., the probability to have a biased pseudorange estimation) when estimating the maximum of the $\text{BOC}_{\cos}(15, 2.5)$ cross-correlation function computed from a signal snapshot in AWGN conditions is relatively important for medium-to-low SNR conditions [1]. As shown in Fig. 6, a probability of false lock above around 20% is observed for SNR values (at post-correlation level per satellite) below around 15 dB (note that a SNR of 15 dB at post-correlation level corresponds to a C/N_0 of 25 dB-Hz for a coherent integration period of 100 ms [10]). This results in a non-negligible probability of having biased position solutions when using the conventional two-steps positioning approach [18], which is used in the following as reference. In the conventional two-steps approach considered in this paper the position solution is computed per signal snapshot based on the application of a weighted least-squares (WLS) solution to the individual pseudorange measurements derived from the estimation of the maximum of the cross-correlation function of the BOC signal for each satellite (which corresponds to the MLE of the pseudorange [10]) when considering a correlation span of ± 1 chip (see Table 1 for further details).

The first simulated scenario considers eleven satellites in view by a static receiver in a representative geometric configuration for which the HDOP is equal to one. An AWGN channel (spatially white for the array of antennas) is considered in the simulations for simplicity since, at medium-to-low SNR conditions, a simple AWGN is sufficient for inducing the ambiguity problem (as proved in [1], [10] and Fig. 6 at pseudorange level, and shown in Fig. 7 at position level). The same SNR conditions are considered for all the received signals, and additional system errors (e.g., satellites' clock and orbit errors) and ionospheric

and tropospheric errors are not included in the simulations. For the MIMO system configuration, four antennas in an arbitrary distribution are simulated in the array of antennas, which attitude and relative position with respect to the receiver phase center is considered to be known *a priori*, and with all the antennas' signals considered to be referenced to the same receiver clock. The phase of the simulated correlation functions at post-correlation level per satellite and antenna is random and independent between satellites and antennas. Therefore, no phase calibration is considered in the array of antennas.

The second simulated scenario is equivalent to the first scenario, but controlled fading and multipath are introduced for some of the simulated propagation paths. In particular, out of the eleven satellites in view by the receiver, the LOS signals of the five satellites with the lowest elevations (which correspond to the satellites in view with an elevation below around 30 degrees) are received with an attenuation of 30 dB with respect to the previous scenario (i.e., a constant fading of 30 dB is introduced to the LOS signals of those satellites). For the remaining six satellites, an additional constant attenuation of the LOS signal of 30 dB and a multipath ray with a relative delay of 10 m and a relative power of -10 dB with respect to the original LOS signal are introduced in the simulation in an incremental way (i.e., added to one more satellite for each new simulation). It is to be noticed that, for the satellites in which controlled fading and multipath are introduced, the multipath ray component is dominant, with 20 dB more power than the attenuated LOS signal. Moreover, the relative delay of the multipath ray with respect to the LOS signal (i.e., 10 m) corresponds approximately to the relative delay of the secondary peak of the autocorrelation function of the $\text{BOC}_{\cos}(15, 2.5)$ with respect to the main peak (see Fig. 2). Thus, the second scenario is considered a worst-case scenario for the pseudorange ambiguity resolution since it is inducing that the maximum of the resulting cross-correlation function is approximately located where the secondary peak of the original autocorrelation function is expected (i.e., biased pseudorange estimations are induced when the MLE of the pseudorange is used). This scenario has been used in order to assess the robustness of the proposed estimators in fading and multipath conditions highly impacting the ambiguity resolution per satellite for a different number of satellites. In the case of the array of antennas, the same fading and multipath conditions are considered for all the antennas for simplicity. Although the simulated fading and multipath conditions are simplified with respect to those observed in real urban canyon propagation scenarios (where multiple refracted, diffracted and/or reflected multipath components are actually received), it is of interest to perform the assessment of the ML-based estimators emulating in a controlled way the harsh propagation conditions that are in practice triggering the main problems that the estimators are expected to be facing when operating in reality (i.e., with an important fading of the LOS signal for many of the satellites in view, and an additional impact of the multipath rays). The simulation parameters are summarized in Table 1.

TABLE 1. SUMMARY OF SIMULATION PARAMETERS

| Parameter | Value |
|------------------------------|--|
| Modulation | BOC _{cos} (15, 2.5) |
| Receiver BW | 40 MHz |
| Correlator spacing | 0.031 chips |
| Correlation Span | ± 1 chip |
| Number of satellites (M) | 11 |
| Number of antennas (N) | 1 (MISO), 4 (MIMO) |
| Noise | AWGN (1 st and 2 nd scenarios) |
| Fading and multipath | Controlled (2 nd scenario) |

The ML-based estimators of the position in the MISO and MIMO system configurations are used to unambiguously estimate the horizontal 2D position of the receiver. The conventional two-steps approach (applied to the single-antenna configuration) is used as reference in order to understand the benefit of jointly exploiting the spatial diversity in the proposed estimators. In the ML-based estimators, the solution is derived considering a search space in the horizontal 2D position domain limited to a square of 100 by 100 m around the truth receiver position, which is a realistic search space considering the availability of an *a priori* coarse position estimation (e.g., based on the position solution obtained from the unambiguous, but noisier, BPSK-envelope of the BOC signal). Based on the assumption of an *a priori* coarse position estimation, other parameters like e.g., the receiver's clock bias, are also considered *a priori* known in the problem, since can be estimated by other means as part of the coarse position estimation. For each simulated scenario, receiver configuration and evaluated SNR value, 1000 Monte-Carlo independent runs are considered for the derivation of the results.

B. Discussion of results

The root-mean-square error (RMSE) of the horizontal position solution obtained for the proposed ML-based estimators in the MISO and MIMO configurations for the first simulated scenario is shown in Fig. 7 with respect to the SNR per satellite's signal at post-correlation level, together with the results obtained for the conventional two-steps approach. Additionally, the lower bound (LB) of the horizontal position error is also included for both single- and multiple-antenna configurations. This LB is computed based on the Cramér-Rao lower bound (CRLB) of the pseudorange estimation per satellite (which, by definition, does not consider the potentially biased estimations), the HDOP and, for the multiple-antenna configuration, also the maximum gain expected to be introduced by the array of antennas (i.e., $10\log_{10}(N)$, with N equal to four in the simulated case).

As can be observed, the conventional two-steps approach is already impacted by the occurrence of false locks at pseudorange level (i.e., biased pseudorange estimations) for SNR values (at post-correlation level) below around 22.5 dB, and only above this value attains the single-antenna LB (which is in line with the probability of false lock in Fig. 6). The ML-based estimator in the MISO configuration is able to attain the single-antenna LB for lower SNR conditions than the conventional two-step approach, down to around 10 dB. This important improvement in the unambiguous estimation of the position is introduced by the joint exploitation of the M satellites' $\text{BOC}_{\text{cos}}(15, 2.5)$ signals in the position domain, which enables an improvement of the equivalent SNR conditions observed by the ML-based estimator in the position domain with respect to the one observed per satellite's signal. In this first simulated scenario, where the same SNR conditions are considered for all the received signals, the observed improvement is of up to $10\log_{10}(M)$ dB. This makes the ML-based estimator in the position domain more robust solving the ambiguity problem than the conventional two-steps approach, in which the ambiguity is solved at pseudorange level. For the MIMO configuration, it is observed that the ML-based estimator attains the multi-antenna LB even at lower SNR conditions than the ML-based estimator for the MISO configuration (from around 10 dB down to 5 dB) thanks to the additional processing gain introduced by the array of antennas, of up to $10\log_{10}(N)$ dB (i.e., 6 dB for the four antennas considered in the simulation).

In order to complete the comparison between the different receiver configurations assessed in the first simulation scenario, Fig. 8 shows the 95-percentile of the horizontal position errors instead of the RMSE shown in Fig. 7. The RMSE is already impacted even when the probability to obtain biased positioning solutions is relatively low, so the 95-percentile figure might be actually more interesting to really understand, from a practical point of view, the robustness of the proposed solution (i.e., for which SNR conditions can we reasonably trust the position solution). In practice, in a typical receiver implementation we might actually filter the position solutions obtained per time epoch (e.g., with a Kalman filter) in order to smooth the final positioning solution and remove potential outliers. In some cases, this process might be also aided by other sources like e.g., inertial sensors. Therefore, it might be reasonable to think that the receiver should be able to handle biased positioning solutions appearing from time to time (e.g., below 5% of the time). Based on this, and assuming the same AWGN conditions for each of the eleven satellites simulated, the conventional two-steps approach can be considered in practice robust for SNR values down to around 20 dB, while the ML-based estimators in the MISO and MIMO configurations can be considered robust for SNR values down to around 7.5 and 2.5 dB, respectively.

Regarding the second simulated scenario, Fig. 9 shows the results obtained for the different receiver configurations assessed in terms of the 95-percentile of the horizontal position errors with respect to the number of satellites impacted by the simulated fading and multipath (as described earlier in this section). Two nominal SNR conditions are considered (with an SNR equal to 15

and 20 dB for the satellites not impacted by fading). As can be observed, the conventional two-step approach is highly impacted by the simulated fading and multipath conditions. On the other hand, the ML-based estimators in the position domain for both MISO and MIMO are robust to the strong fading and multipath conditions simulated. In particular, the MIMO ML-based estimator shows horizontal errors (95-perc) below the meter, even with four satellites impacted by a multipath bias of 10 m and only two satellites in LOS conditions (for the worst case in which the nominal SNR is set to 15 dB, the horizontal error (95-perc) for the MIMO ML-based solution is 0.86 m, with respect to around 36 m for the MISO ML-based solution, and around 125 m for the conventional two-steps approach).

V. CONCLUSION

The unambiguous positioning problem with high-order BOC signals in harsh propagation conditions has been presented when considering a GNSS receiver featuring a single antenna and an array of antennas. In particular, it has been proposed to tackle the ambiguity resolution problem directly in the position domain, enabling the joint exploitation of all the BOC signals received by the GNSS receiver. For this purpose, the ML-based estimators in the resulting MISO- and MIMO-GNSS systems have been derived.

The simulation results obtained show that the MISO ML-based estimator in the position domain outperforms the conventional two-steps positioning approach in both AWGN and fading conditions, being more robust in the unambiguous positioning with BOC signals, and resulting in a lower occurrence of biases in the position solution. Indeed, the joint exploitation of the BOC signals received from all the satellites in view allows the MISO ML-based estimator to attain the lower bound of the position estimation for lower SNR values per satellite's signal thanks to the transmission diversity gain. For the MIMO ML-based estimator, an additional improvement of the position performance is obtained thanks to the processing gain introduced by the array of antennas. In this case, the lower bound is attained even at relatively low SNR conditions, and the position estimator is very robust even when the signals from multiple satellites are impacted by severe fading and multipath conditions. Therefore, the proposed estimators are a promising approach to enable the unambiguous positioning of high-order BOC signals in harsh propagation conditions typical of urban environments, while being implementable based on state-of-the-art multi-correlator receiver architectures.

REFERENCES

- [1] Garcia-Molina, J. A., Navarro-Gallardo, M., Lopez-Risueno, G., and Crisci, M., "Robust Unambiguous Estimation of High-Order BOC Signals: the DOME Approach," *NAVIGATION: Journal of The Institute of Navigation*, vol. 63, no. 4, pp. 509-518, Winter 2016.

- [2] Martin, N., Leblond, V., Guillotel, G., and Heiries, V., "BOC(x,y) Signal Acquisition Techniques and Performances," *ION GPS/GNSS 2003*, Portland, OR, Sep. 2003.
- [3] Kim, S., Yoo, S., Yoon, S., and Kim, S. Y., "A Novel Unambiguous Multipath Mitigation Scheme for BOC(kn,n) Tracking in GNSS," *Proceedings of the 2007 International Symposium on Applications and the Internet Workshops (SAINTW'07)*.
- [4] Navarro-Gallardo, M., Seco-Granados, G., López-Risueño, G., and Crisci, M., "Analysis of Side Lobes Cancellation Methods for BOCcos(n,m) Signals", *NAVITEC 2012*, Dec 5-7, 2012.
- [5] Fine, P., and Wilson, W., "Tracking Algorithm for GPS Offset Carrier Signals", *Proceedings of the 1999 National Technical Meeting of The Institute of Navigation*, January 25 - 27, 1999, San Diego, CA.
- [6] Hodgart, M., Blunt, P., and Unwin, M., "The Optimal Dual Estimate Solution for Robust Tracking of Binary Offset Carrier (BOC) Modulation", *ION GNSS 2007*, Fort Worth, TX.
- [7] Navarro-Gallardo, M., Seco-Granados, G., López-Risueño, G., and Crisci, M., "Code Smoothing for BOC Ambiguity Mitigation", *ICL-GNSS 2013*, Florence, Italy, Oct. 2013.
- [8] Schubert, F. M., and Wendel, J., "BOC Tracking Using Phase and Subcarrier Locked Loops", *6th European Workshop on GNSS Signals and Signal Processing*, Dec 5-6, 2013, Neubiberg, Germany.
- [9] Garcia-Molina, J. A., Navarro-Gallardo, M., Lopez-Risueno, G., and Crisci, M., "Unambiguous Tracking of High-Order BOC Signals in Urban Environments: Channel Considerations," *NAVITEC 2014*, Noordwijk, The Netherlands, December 2014.
- [10] Gusi, A., Closas, P., and Garcia-Molina, J. A., "False Lock Probability in BOC Signals", *ION ITM 2016*, California, USA, January 2016.
- [11] Wendel, J., Schubert, F. M., and Hager, S., "A Robust Technique for Unambiguous BOC Tracking," *NAVIGATION: Journal of The Institute of Navigation*, vol. 61, no. 3, pp. 179-190, Fall 2014.
- [12] Garcia-Molina, J. A., "Method and Apparatus for Tracking a Binary Offset Carrier Navigation Signal," European Patent Application No. EP15171363.3, Jun 10 2015.
- [13] Seco-Granados, G., Lopez-Salcedo, J.A., Jimenez-Banos, D., and Lopez-Risueno, G., "Challenges in Indoor Global Navigation Satellite Systems: Unveiling its core features in signal processing," *IEEE Signal Processing Magazine*, vol. 29, no. 2, pp. 108 -131, 2012.
- [14] Pany, T., Riedl, D., Winkel, J., Worz, T., Schweikert, Niedermeir, H., Lagrasta, S., Lopez-Risueno, G., and Jimenez-Banos, D., "Coherent Integration Time: The Longer, the Better", *Inside GNSS*, pp. 52-61, November/December 2009.
- [15] Broumandan, A., Nielsen, J., and Lachapelle, G., "Coherent Integration Time Limits for Mobile GNSS Receivers in Multipath Fading Environments", *Inside GNSS*, pp. 62-65, March/April 2011.
- [16] DiEsposti, R., "GPS PRN Code Signal Processing and Receiver Design for Simultaneous All-in-View Coherent Signal Acquisition and Navigation Solution Determination", *Proceedings of the 2007 National Technical Meeting of The Institute of Navigation*, San Diego, CA, January 2007, pp. 91-103
- [17] Closas, P., Fernández-Prades, C., and Fernández-Rubio, J. A., "Maximum Likelihood Estimation of Position in GNSS," *IEEE Signal Processing Lett.*, vol. 14, no. 5, pp. 359-362, May 2007.
- [18] Closas, P., Fernández-Prades, C., and Fernández-Rubio, J. A., "Direct Position Estimation approach outperforms conventional two-steps positioning", in *Proc. XVII European Signal Processing Conference, EUSIPCO*, Glasgow, Scotland, August 2009, in Special Session.
- [19] Axelrad, P., Donna, J., and Mitchell, M., "Enhancing GNSS Acquisition by Combining Signals from Multiple Channels and Satellites", *Proceedings of the 22nd International Technical Meeting of The Satellite Division of the Institute of Navigation (ION GNSS 2009)*, Savannah, GA, September 2009, pp. 2617-2628.
- [20] Bradley, B. K., Axelrad, P., Donna, J., "Performance Analysis of Collective Detection of Weak GPS Signals", *Proceedings of the 23rd International Technical Meeting of The Satellite Division of the Institute of Navigation (ION GNSS 2010)*, Portland, OR, September 2010, pp. 3041-3053.

- [21] Cheong, J. W., "Towards Multi-Constellation Collective Detection for Weak Signals: A Comparative Experimental Analysis," *Proceedings of the 24th International Technical Meeting of The Satellite Division of the Institute of Navigation (ION GNSS 2011)*, Portland, OR, September 2011, pp. 3709-3719.
- [22] Axelrad, P., Bradley, B. K., Donna, J., Mitchell, M., and Mohiuddin, S., "Collective Detection and Direct Positioning Using Multiple GNSS Satellites," in *NAVIGATION: Journal of the Institute of Navigation*, vol. 58, no. 4, pp. 305-321, Winter 2011.
- [23] Cheong, J.W., Wu, J., Dempster, and A. G., Rizos, C., "Efficient Implementation of Collective Detection", *IGNSS Symposium 2011*, University of New South Wales, Sydney, November 2011.
- [24] Enneking, C., Stein, M., Castenada, M., Antreich, F., and Nossek, J.A., "Multi-Satellite Time-Delay Estimation for Reliable High-Resolution GNSS Receivers," in *Proc. IEEE/ION Position Location and Navigation Symposium (PLANS)*, South Carolina, U.S., April 2012.
- [25] Cheong, J.W., Wu, J., Dempster, and A. G., Rizos, C., "Assisted-GPS Based Snap-Shot GPS Receiver with FFT-accelerated Collective Detection: Time Synchronisation and Search Space Analysis," *Proceedings of the 25th International Technical Meeting of The Satellite Division of the Institute of Navigation (ION GNSS 2012)*, Nashville, TN, September 2012, pp. 2357-2370.
- [26] Li, L., Cheong, J. W., Wu, J., and Dempster, A. G., "Improvement to Multi-resolution Collective Detection in GNSS Receivers," *The Journal of Navigation*, vol. 67, pp. 277-293, March 2014.
- [27] Esteves, P., Sahmoudi, M., and M., Ries, L., "Collective Detection of Multi-GNSS Signals," *Inside GNSS*, pp. 54-65, May/June 2014.
- [28] Narula, L., Singh, K. P., M. G. Petovello, "Accelerated Collective Detection Technique for Weak GNSS Signal Environment," *Ubiquitous Positioning Indoor Navigation and Location Based Service (UPINLBS)*, Corpus Christ, TX, USA, November 2014.
- [29] Andrianarison, M., Sahmoudi, M., and Landry, R., "Efficient and Innovative Techniques for Collective Acquisition of Weak GNSS Signals," *Journal of Computer and Communications*, 5, 85-113, April 2017.
- [30] Fernandez-Prades, C., Arribas, J., and Closas, P., "The Decoupling of DOA/Synchronization Parameters in Colored Noise Environments", *NEW-COM++/ACoRN Joint Workshop*, Barcelona, Spain, March 2009.
- [31] Fernandez-Prades, C., and Closas, P., "Synchronization of GNSS Signals with Unstructured Antenna Arrays by a Multivariate Minimization of the Generalized Variance", *16th International Conference on Digital Signal Processing (DSP 2009)*, Santorini, Greece, July 2009.
- [32] Fernández-Prades, C., Arribas, J., Closas, P., "Robust GNSS Receivers by Array Signal Processing: Theory and Implementation," *Proceedings of the IEEE*, vol. 104, issue 6, pp. 1207-1220, June 2016.
- [33] Seco-Granados, G., Fernandez-Rubio, J. A., and Fernandez-Prades, C., "ML Estimator and Hybrid Beamformer for Multipath and Interference Mitigation in GNSS Receivers," *IEEE Transactions on Signal Processing*, vol. 53, no. 3, pp. 1194 - 1208, March 2005.
- [34] Steingass, A., and Lehner, A., "Land Mobile Satellite Navigation. Characteristics of the Multipath Channel," in *Proc. Institute of Navigation (ION GPS/GNSS)*, Portland, U.S., Sep. 2003.
- [35] Hein, G., and Teuber, A., "GNSS Indoors. Fighting the Fading. Part 3," *Inside GNSS*, pp. 45-53, July/August 2008.
- [36] Kaplan, E. D., and Hegarty, C. J., "Understanding GPS. Principles and Applications", Norwood, MA: Artech House Publishers, 1996.
- [37] Kay, S. M., "Fundamentals of Statistical Signal Processing: Estimation Theory," Upper Saddle River, NJ: Prentice Hall PTR, 1993.

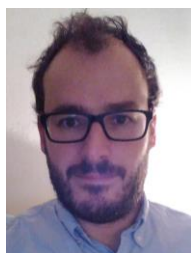

José Antonio García-Molina (M'17) received the M.Sc. in electrical engineering from the Technical University of Catalonia (UPC), Barcelona, Spain, in 2009.

He is a Radio Navigation engineer at the European Space Agency (ESA/ESTEC) in Noordwijk, The Netherlands, where he leads several R&D projects and internal research activities on GNSS receiver technology and signal processing techniques for ground and space applications in the context of different ESA programs (including Galileo). His main research interests include signal processing and estimation

theory, GNSS/Galileo receivers and signals, unambiguous estimation of high-order BOC signals, cloud GNSS receivers, collaborative positioning, and MIMO-GNSS signal processing.



Juan Antonio Fernández-Rubio (S'74-M'78-SM'05) received the Ph.D. degree in electrical engineering from the Technical University of Catalonia (UPC), Barcelona, Spain, in 1982. He has been developing his teaching and research activities in the UPC since 1974. He taught Electromagnetic Fields, Signal Processing in Communication, Mathematical Methods for Communications, Array Signal Processing and GNSS systems. He was the advisor of nine PhD students. He was director of the Telecommunication School of Barcelona from 2000 until 2006 and president of the Spanish Institute of Navigation from 2004 until 2007. He was coordinator in the Evaluation and Prospective Spanish Agency (ANEP) for the IST program from 2000 until 2003. He is the author of more than 100 articles in recognized journals and conferences. He is a life senior member of the IEEE.

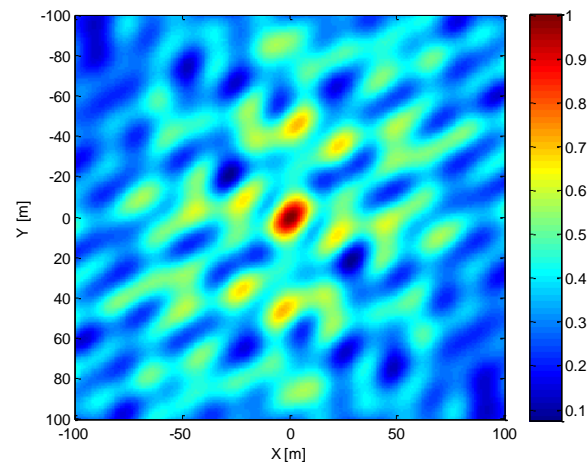

Fig. 1. Representation of the normalized cost function in the horizontal position plane resulting from a scenario with eleven satellites (with an equivalent HDOP equal to 1.0) transmitting $\text{BOC}_{\cos}(15, 2.5)$ signals when considering high SNR conditions for all the satellites.

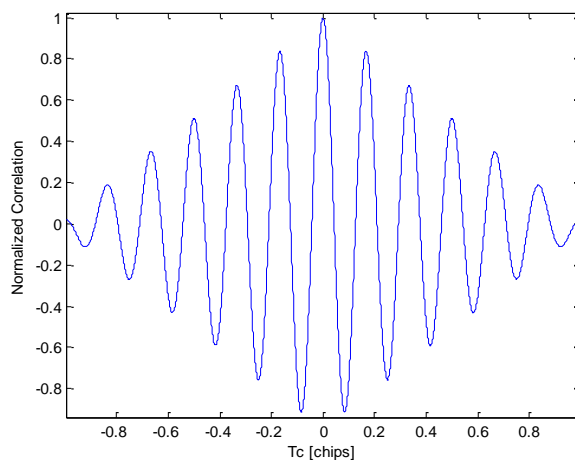

Fig. 2. Normalized autocorrelation function for a $\text{BOC}_{\cos}(15, 2.5)$ signal.

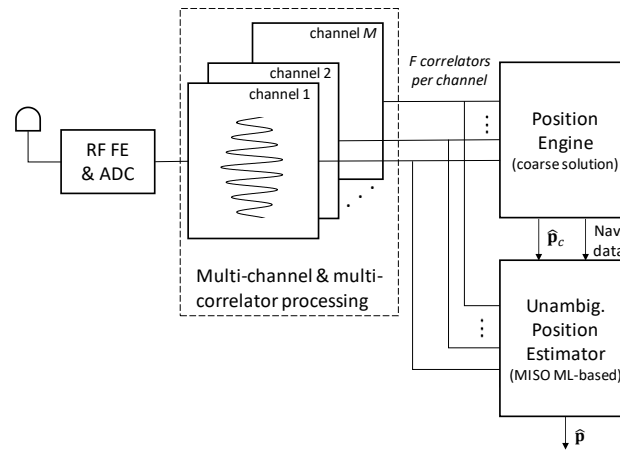

Fig. 3. High-level block diagram of a multi-correlator-based GNSS receiver applying the unambiguous ML-based position estimator in the MISO configuration.

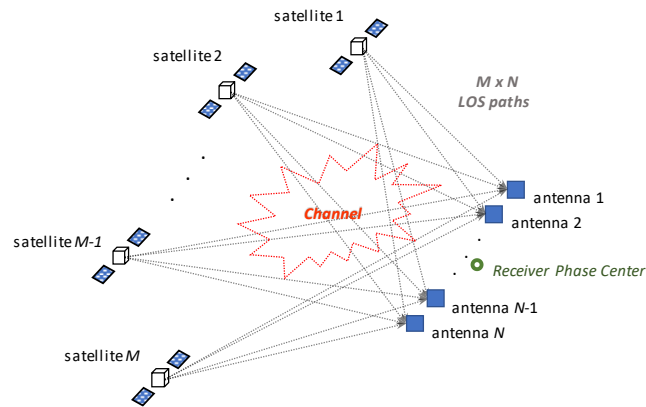

Fig. 4. Representation of the MIMO-GNSS system. Only the MN LOS signals are shown, while additional non-LOS signals can be introduced by the propagation channel.

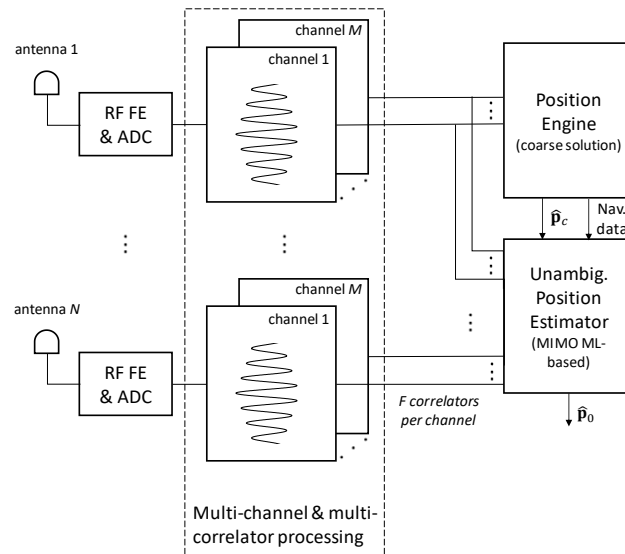

Fig. 5. High-level block diagram of a multi-antenna and multi-correlator-based GNSS receiver applying the unambiguous ML-based position estimator in the MIMO configuration.

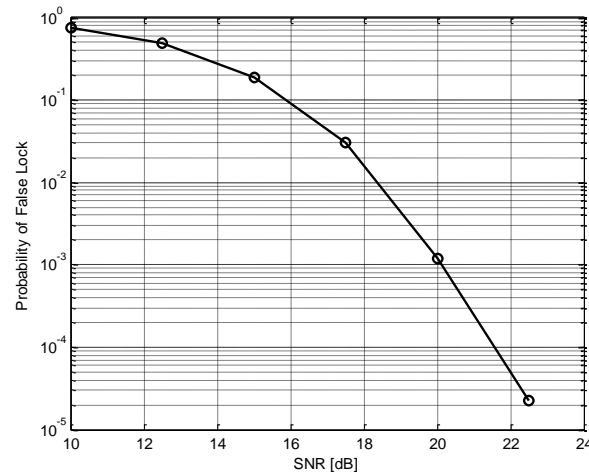

Fig. 6. Probability of false lock for a $\text{BOC}_{\text{cos}}(15, 2.5)$ signal in AWGN conditions when considering the MLE of the pseudorange (i.e., based on the search of the maximum of the cross-correlation function; the full span of the correlation function (± 1 chip) is considered in the search operation)

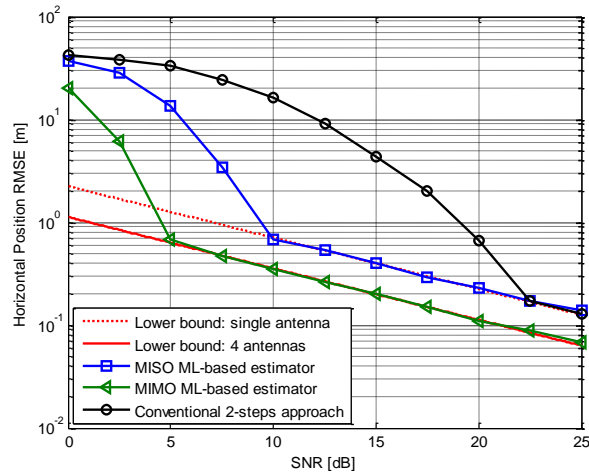

Fig. 7. RMSE of the horizontal position estimated with the ML-based solution in the MIMO and MISO configurations and the conventional two-steps approach in an AWGN channel.

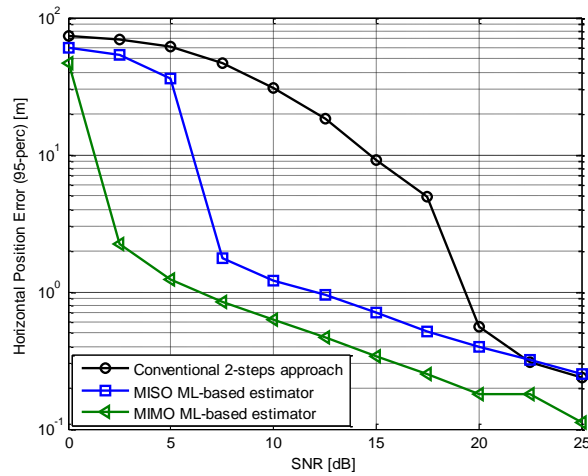

Fig. 8. Horizontal position error (95-perc) for the results shown in Fig. 7.

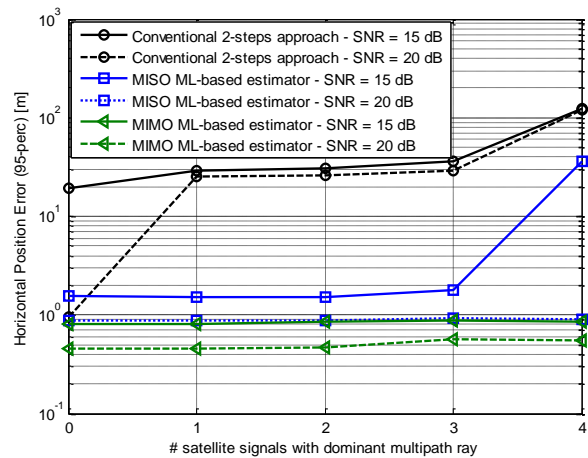

Fig. 9. Horizontal position error (95-perc) for the second simulated scenario with SNR set to 15 and 20 dB for the nominal LOS signals.