

Current Source for LED Drivers Based on a Linear-Assisted DC/DC Regulator

Herminio Martinez-Garcia

Department of Electronics Engineering
Eastern Barcelona School of Engineering (Escola d'Enginyeria de Barcelona Est, EEBE)
Technical University of Catalonia (UPC). BarcelonaTech
Diagonal-Besòs Campus. Eduard Maristany Ave., n° 10 – 14
E-08019 - Barcelona. SPAIN
E-mail: herminio.martinez@upc.edu

Abstract—This article presents a proposal of current source based on a linear-assisted DC/DC converter, in which a linear voltage regulator assists a switching DC/DC converter in order to obtain a compact circuit with advantages of both alternatives; i.e., high efficiency (similar to the switching converter), and low output ripple and fast reaction to the load changes (similar to the linear regulator). In order to reduce the power dissipation in the linear regulator, it is considered as an assisted circuit for providing just a little fraction of the load current. Furthermore, this stage provides the required clock signal for the switching counterpart, resulting in reduction of the complexity in the design of the control scheme for the switching converter and a compact topology, especially for on-chip practical implementations, since no output capacitors are required. This last advantage provides the possibility of obtaining good-performance current-source drivers for LED technology in lighting applications. The implementation and results indicate that the proposed linear-assisted DC/DC regulator-based current source can achieve a notably compacting and higher performance, while consuming less power in comparison to linear alternatives.

Keywords—Switching DC/DC converters; linear voltage regulators; linear-assisted DC/DC voltage regulators; current sources.

I. INTRODUCTION

In recent years, the demands for energy-saving, perennial, and low-cost lighting sources have been increased. Nowadays, the paradigm of the aforementioned lighting sources is based on LED technology. In fact, high efficient and reliable LED chips with enhanced packaging have been presented for last years [1, 2]. However, providing low cost and reliable LED drivers, which play important role in a high quality LED lighting fixture, is still a challenge.

Nowadays there are two common driver methods for LED light sources: (1) Voltage regulatory LED driver circuits, and (2) constant current LED driver circuits. However, the constant current alternative is favorable for obtaining improved performance LED drivers. It has some interesting advantages; e.g., under constant current circuit, the output current remains stable and constant while the output voltage varies with load resistance values. Additionally, the constant current LED driver

circuit can still work under short-cut circuit circumstance. Thus, for LED lighting applications, constant current circuit is rather plausible although the cost could be undesirable in some implementations. Current sources can be implemented using linear implementations. However, they have poor efficiency as a main disadvantage.

The second possibility is to use switching-mode current sources. In this case, although the efficiency that can be achieved is good enough, the design, especially the control block, and their practical implementation is a complicated and difficult task.

This article presents an alternative of current source based on linear-assisted DC/DC converter, in which a linear block assists a switching DC/DC converter in order to achieve a circuit with advantages of both alternatives.

The paper is organized as follows: In Section II, the operation of linear-assisted DC/DC voltage regulators with variable switching frequency is presented. Next, in Section III, the proposal and design of a current source for LED drivers based on a linear-assisted DC/DC voltage regulator is discussed. In Section IV, simulation results of the proposed linear-assisted current source for LED drivers are obtained, including comparison results with the classic linear current source and its switching counterpart. Finally, Section 5 collects the main conclusions of the article.

II. OPERATION OF LINEAR-ASSISTED DC/DC VOLTAGE REGULATORS

A linear-assisted DC/DC regulator (Fig. 1) consists of a linear regulator and a switching DC/DC converter working together. The control of the second one (in this case a buck or step-down converter) is carried out using a hysteretic control, in which the current flowing through the linear regulator is sensed.

As it is observed in Fig. 2, the proposed configuration uses an analog comparator (CMP_1) that controls the conduction or cut-off mode of the transistor Q_1 and fixes the switching frequency of the switching converter [3, 4]. Notice that the

objective of the switching converter is to provide the excess current that the linear regulator does not supply. Consequently:

$$I_{out} = i_{reg}(t) + i_L(t) \quad (1)$$

The control of the switching converter is determined by the aforementioned analog comparator. If the load current is below a boundary current value, named *threshold switching current*, I_γ , the output of the comparator CMP_1 is held low. Therefore, the switching converter will be disabled and, as a consequence, the current through the inductance L_1 will be zero. As a result, the linear regulator supplies the load R_L , providing all the output current ($I_{reg}=I_{out}$).

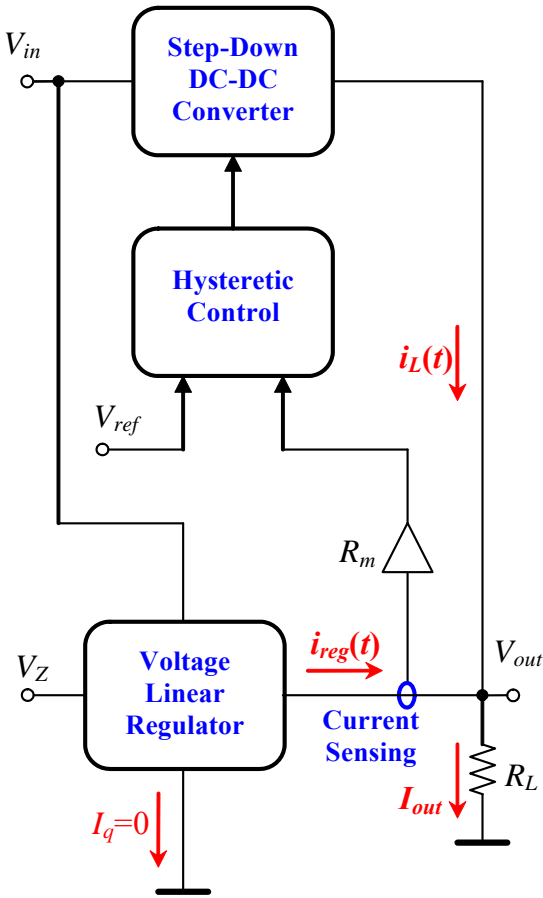

Fig. 1. Block diagram of the basic structure of a linear-assisted DC/DC hybrid voltage regulator that supplies a load R_L .

The aforementioned boundary *threshold switching current*, I_γ , is determined by the reference voltage V_{ref} and the sensor transresistance R_m , as below:

$$I_\gamma = \frac{V_{ref}}{R_m} \quad (2)$$

When the load current is lower than I_γ , the switching converter will be disabled and, as a consequence, the load current is satisfied by the linear regulator.

Nevertheless, for a load current greater than I_γ , the switching converter is enabled through the control signal provided by the analogue comparator, increasing the converter output current linearly, in order to provide the excess load current. In this case, considering that the load current I_{out} is constant and equal to:

$$I_\gamma = \frac{V_{ref}}{R_m}, \quad (3)$$

the current of linear regulator $i_{reg}(t)$ will tend to decrease in a linear way (Fig. 3), just reaching a value below I_γ .

It is noted that, selecting a suitable I_γ (with the objective of not decreasing the efficiency), the circuit has the capability to provide almost all the output current I_{out} thanks to the switching DC/DC converter. In fact, under these conditions, only a few part of the aforementioned output current is provided by the linear regulator, which acts as an “active output capacitor” in order to remove output voltage ripples.

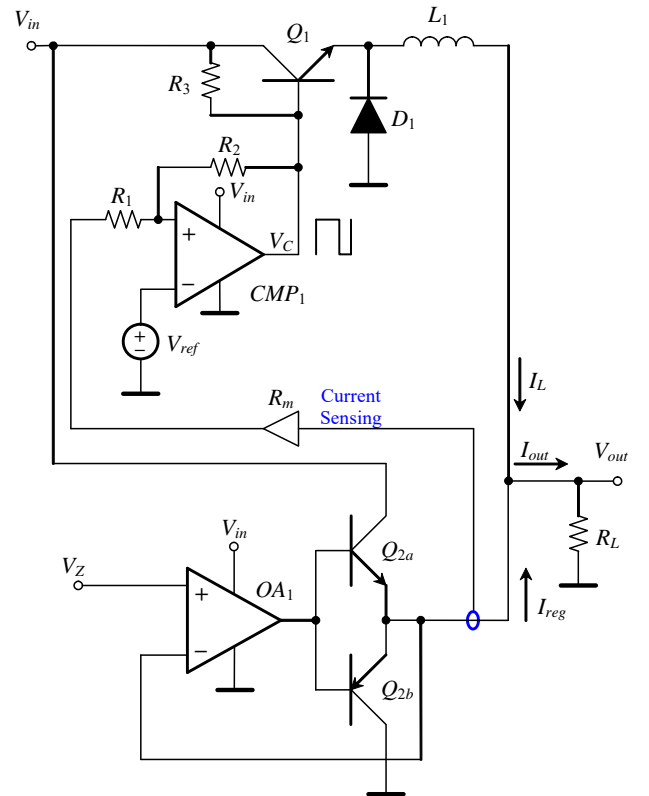

Fig. 2. Basic circuit of a linear-assisted DC/DC hybrid voltage regulator that supplies a load R_L .

Moreover, with the objective of not decreasing the efficiency of the linear-assisted regulator, the value of the dissipated power by the internal transistor of the linear

regulator must be reduced to the utmost. For this reason, the current I_γ has to be the minimum and necessary value to make the linear regulator works properly, without penalizing its good regulation characteristics.

As a consequence, in order to maintain the efficiency at the same level of a sole buck converter, the linear regulator is considered as an *assisting* circuit that fixes the output value and provides just a little fraction of the load current while the excess current is supported by the switching converter.

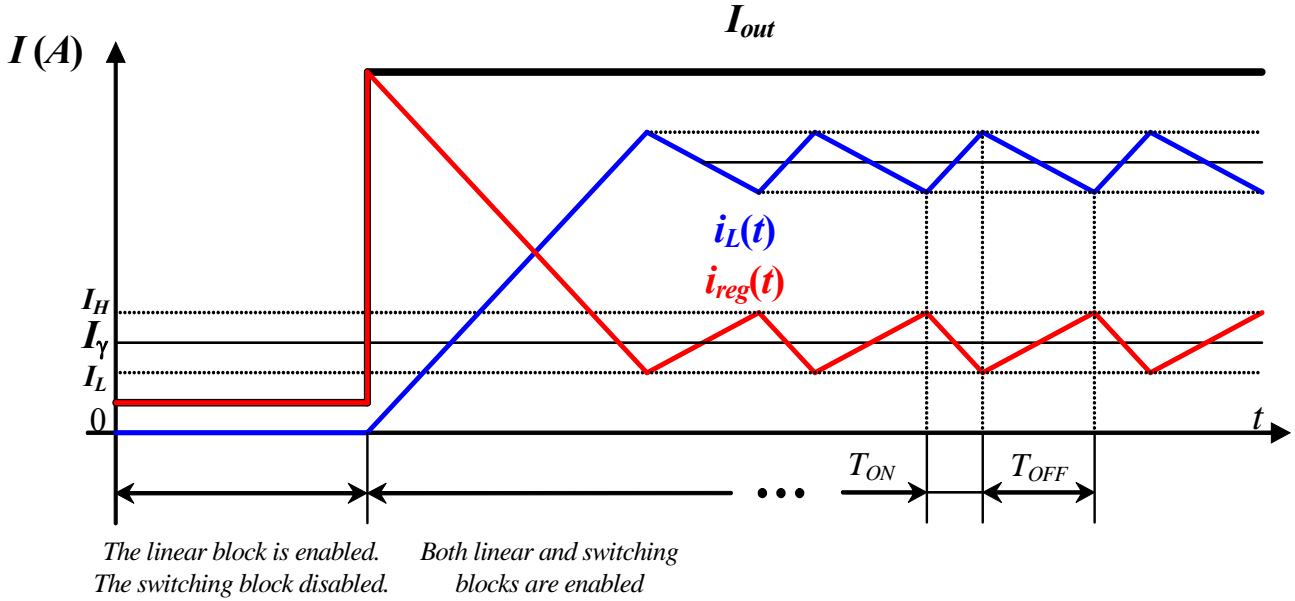

Fig. 3. Output load current (I_{out}), switching DC/DC converter's output current ($i_L(t)$), and linear voltage regulator's current ($i_{reg}(t)$) in the steady state.

Regarding the switching frequency, if we do not consider any hysteresis in the comparator CMP_1 at the first approximation, the delays of the electronic circuits determine a little hysteresis that limits the maximum value of this switching frequency. However, with the objective of fixing this maximum frequency to a suitable value (in order not to increase the switching losses, significantly), it is convenient to add a hysteresis to the comparator CMP_1 (fixed by resistors R_1 and R_2). The switching frequency is given by (4) [5], being the upper and lower switching threshold levels of the analogue comparator (that is, the Schmitt trigger) V_H and V_L , respectively.

$$f = \frac{R_{lim}}{L_1} \frac{V_{out}}{V_H - V_L} \left(1 - \frac{V_{out}}{V_{in}} \right) \quad (4)$$

From (4), we obtain the switching frequency is a function of the hysteresis of the comparator, input and output voltages, and R_{lim} and L_1 values. This dependency from the aforementioned parameters is an important drawback that the circuit could have. Note that the switching frequency depends on the possible disturbances in V_{in} and tolerances and dispersions in passive components of the linear-assisted regulator. The experimental implementation of the self-switched hybrid regulator presented in Fig. 2 can be found in [4] and [5].

III. PROPOSED CIRCUIT OF THE CURRENT SOURCE FOR LED DRIVERS BASED ON A LINEAR-ASSISTED DC/DC VOLTAGE REGULATOR

Starting from the circuit presented in Fig. 2, in which a linear-assisted DC/DC voltage regulator is obtained, this works presents a linear-assisted current source suitable for LED driver circuits.

In particular, Figs. 4 and 5 show the block diagram and circuit implementation, respectively, of the proposal for the linear-assisted DC/DC regulator-based current source. R_{lim} , together with the voltage provided by the linear regulator, fixes the load current according to:

$$I_{out} = \frac{V_{reg}}{R_{lim}} \quad (5)$$

Therefore, if the output voltage V_{reg} of the linear regulator is constant (thanks to its reference voltage V_Z), the output current provided by the circuit will be also constant, independently of the load. In addition, like the standard linear-assisted DC/DC voltage regulator (shown in Fig. 1), in the linear-assisted-based current source the output current is given by (6):

$$I_{out} = i_{reg}(t) + i_L(t) \quad (6)$$

Again, both reference voltage V_{ref} and sensor transresistance R_m determine the value of the threshold switching current I_γ , according to (2). This is the maximum value of the average current flowing through the linear regulator block, as we can appreciate in Fig. 3. Thus, if the output current overtakes this value, the difference will be provided by the switching converter.

IV. RESULTS AND COMPARISON

The discussed linear-assisted DC/DC regulator-based current source is designed and simulated using a discrete implementation in order to explore and characterize the validity of the proposals. Fig. 6 shows the transient response from a system that provides 1.0 A at the output load (adjusting $R_{lim}=0.5 \Omega$ and $V_Z=0.5 V$). The value of the inductor is $L=100 \mu H$ and $I_\gamma=200 mA$ (adjusting $R_m=1 \Omega$ and $V_{ref}=0.2 V$). At $t=100 \mu s$ the load changes from 3Ω to 2Ω (a decrease of 50%), and the input voltage increases from 10 V to 15 V (a variation of 50%) at $t=300 \mu s$. Notice the required independence of the output current from input voltage variations and output load variations.

Finally, in order to corroborate the efficiency of the proposed current source, Fig. 7 shows the efficiency of the circuit compared to the single switching and linear blocks. Notice that the efficiencies for the linear-assisted current source and switching DC/DC converter are very similar, especially in full-load conditions. In particular the maximum efficiency for the whole regulator-based current source is 89% when the maximum efficiency for the switching converter is slightly higher (around 90%).

V. CONCLUSION

In this article a proposal of current source based on a linear-assisted DC/DC converter is presented, in which a linear voltage regulator assists a switching DC/DC converter in order to obtain a compact circuit with advantages of both alternatives. The power dissipation of the linear regulator is considered low as it provides just a little fraction of the load current. Furthermore, this stage provides the required clock signal for the switching counterpart, resulting in reduction of the complexity of the control circuit required for the switching converter.

Thus, the linear regulator is considered as an *assisting* circuit for providing just a little fraction of the load current while the excess current is supported by the switching converter. Additionally, an on-chip compact implementation can be achieved due to eliminating the output capacitors, providing the possibility of obtaining good-performance current-source drivers for LED technology in lighting application.

The implementation and results indicate that the proposed linear-assisted DC/DC regulator-based current source can achieve a notably compacting and higher performance, while consuming less power, in comparison to linear alternatives.

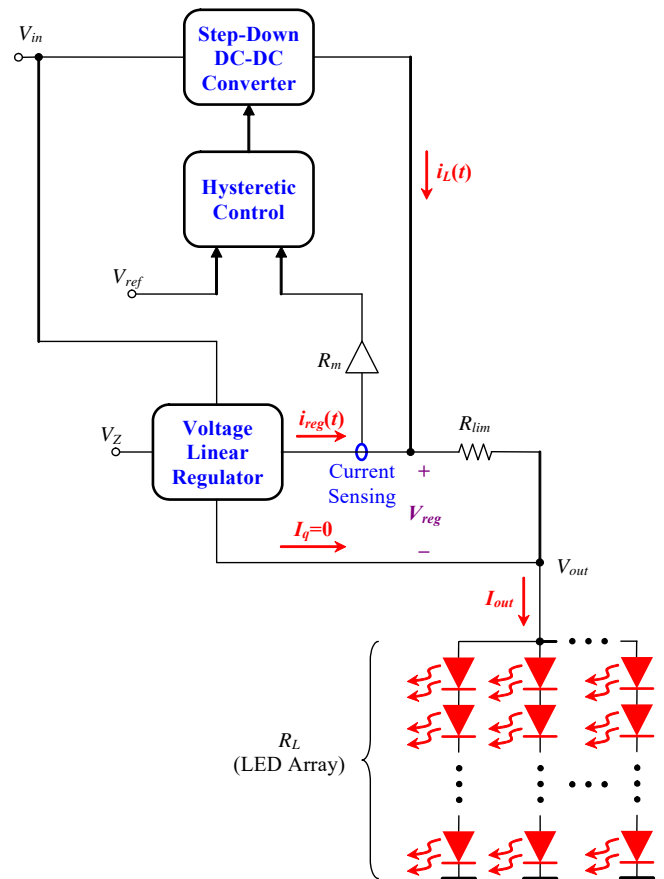

Fig. 4. Block diagram of the proposal of the linear-assisted DC/DC regulator-based current source that supplies a LED array.

ACKNOWLEDGMENT

This work has been partially supported and funded by the Spanish Ministerio de Economía y Competitividad by projects DPI2013-47799-C2-2-R and DPI2016-78957-R, and the LOGIMATIC EU project H2020-Galileo-2015-687534.

REFERENCES

- [1] Sun, G., Liu, J.G., Zhang, H., Wang, D., and Fan, Z.F.: 'A fully-integrated compact LED module with inductor-less and capacitor-less LED driver'. 2013 10th China International Forum on Solid State Lighting (ChinaSSL), Beijing, China, Nov. 2013, pp. 8–11.
- [2] Mirvakili, A., and Koomson, V.J.: 'A flicker-free CMOS LED driver control circuit for visible light communication enabling concurrent data transmission and dimming control', *Analog Integrated Circuits and Signal Processing*, Aug. 2014, Vol. 80, n° 2, pp 283–292.
- [3] Martínez, H., and Conesa, A.: 'Modeling of linear-assisted DC-DC converters', 18th European Conference on Circuit Theory and Design, (ECCTD 2007), Seville, Spain, Dec. 2007, pp. 611–614.
- [4] Cosp, J., and Martínez, H.: 'Design of an on-chip linear-assisted DC-DC voltage regulator', 20th IEEE Inf. Conf. on Electronics, Circuits and Systems (ICECS'13), Abu Dhabi, UAE, Dec. 2013, pp. 353–356.
- [5] Martínez-García, H.: 'Design of a constant switching frequency control-based linear-Assisted DC/DC regulator for photovoltaic solar-powered facilities'. Proc. 2015 IEEE 6th International Symposium on Power Electronics for Distributed Generation Systems (PEDG 2015), Aachen, Germany, 22nd–25th June 2015, pp. 1–5

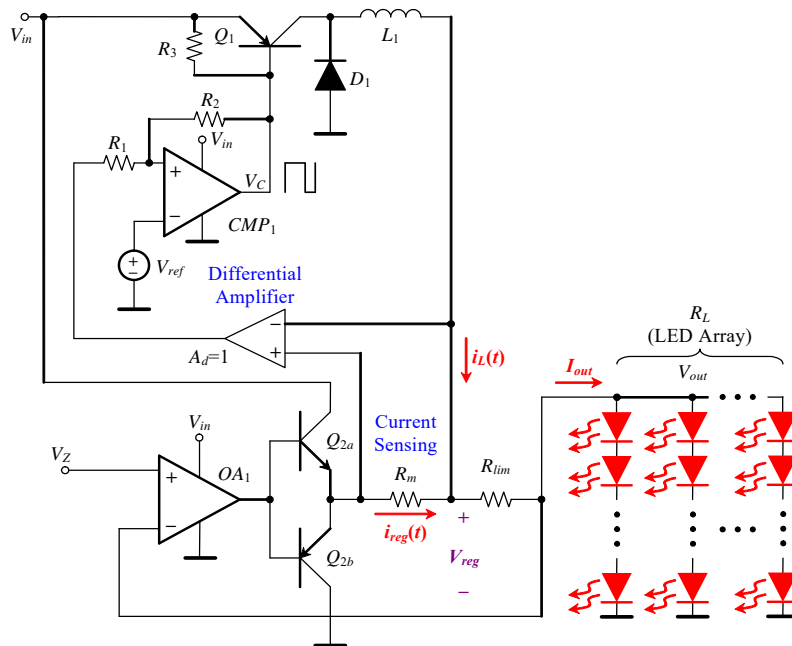

Fig. 5. Circuit implementation of the linear-assisted DC/DC regulator-based current source.

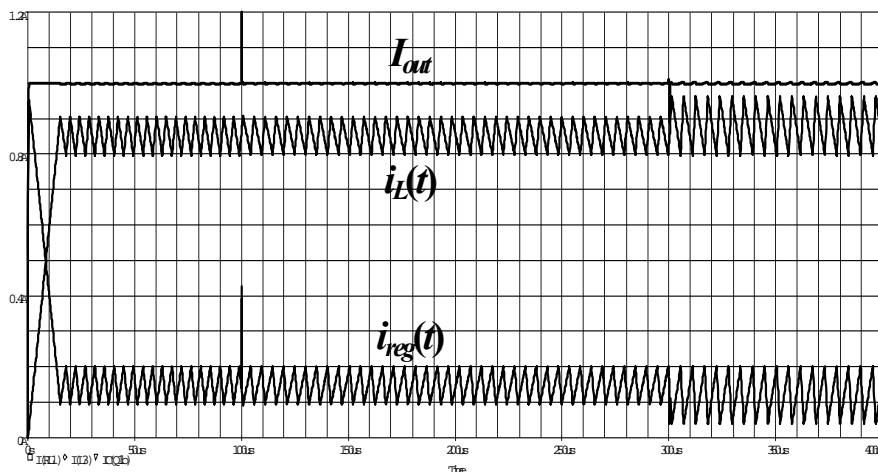

Fig. 6. Output current and currents flowing through buck converter's inductance L_1 , and linear regulator in the steady state.

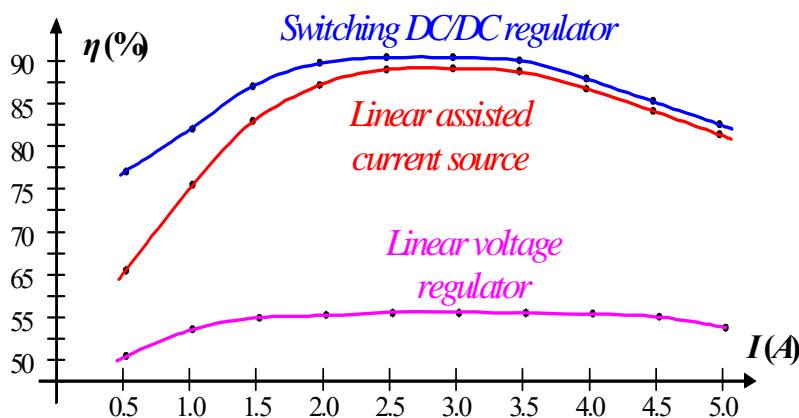

Fig. 7. Comparison of efficiencies of the switching DC/DC regulator (blue line), the linear-assisted current source (red line) and the linear-voltage regulator (pink line) with respect to variation in output current.