



Escola Universitària d'Enginyeria
Tècnica Industrial de Barcelona
Consorci Escola Industrial de Barcelona

UNIVERSITAT POLITÈCNICA DE CATALUNYA

Volumen II

Planos

TRABAJO DE FINAL DE GRADO

“Simulación CFD sistema de combustible Dual-Fuel en MCI (Motor Combustión Interna)”

TFG presentado para optar al título de GRADO en
INGIENIERÍA MECÁNICA
por **Adrián Yáñez Vallverdú**



Barcelona, 11 de Octubre de 2016

Director: Carlos Ruiz Moya
Departamento de fluidos (DMF)
Universitat Politècnica de Catalunya (UPC)

ÍNDICE PLANOS

1.	Pieza 1: Depósito GNL.....	1
2.	Pieza 2: Válvula solenoide o del depósito.....	2
3.	Pieza 3: Válvula de corte manual	3
4.	Pieza 4: Filtro de combustible.....	4
5.	Pieza 5: Manómetro.....	5
6.	Pieza 6: Sensor de presión del depósito	6
7.	Pieza 7: Regulador de la presión del gas	7
8.	Pieza 8: Válvula de seguridad del regulador de gas	8
9.	Pieza 9: Válvula solenoide de corte de gas, baja presión	9
10.	Piezas 10 y 11: Sensor de temperatura y presión del combustible en la rampa del combustible y rampa de combustible.	10
11.	Pieza 12: Inyectores	11

Las 3 vistas de cada pieza (alzado, planta y lateral izquierda) según sistema ISO y la vista isométrica:

1. Pieza 1: Depósito GNL



Figura 1. Alzado



Figura 2. Lateral izquierdo

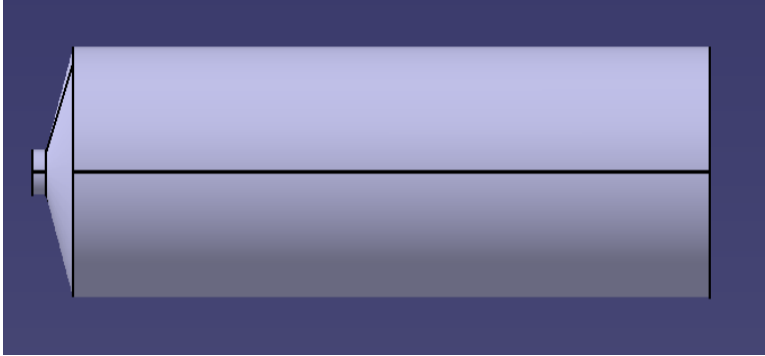

Figura 3. Planta

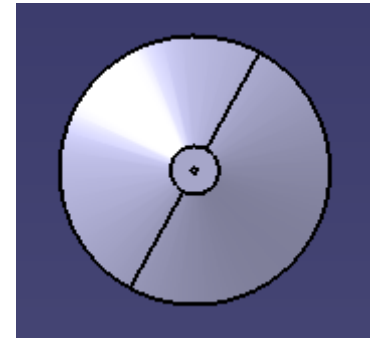

Figura 4. Isométrica

2. Pieza 2: Válvula solenoide o del depósito

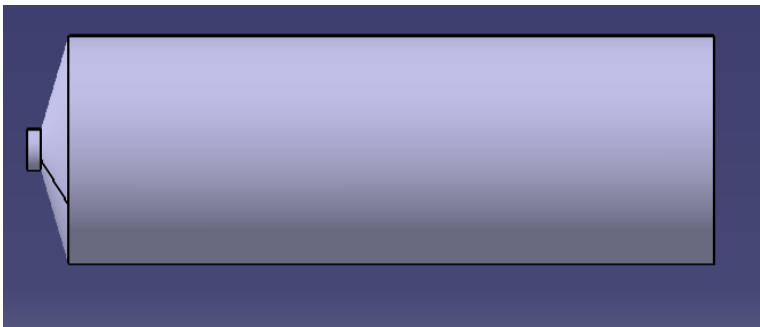

Figura 5. Alzado

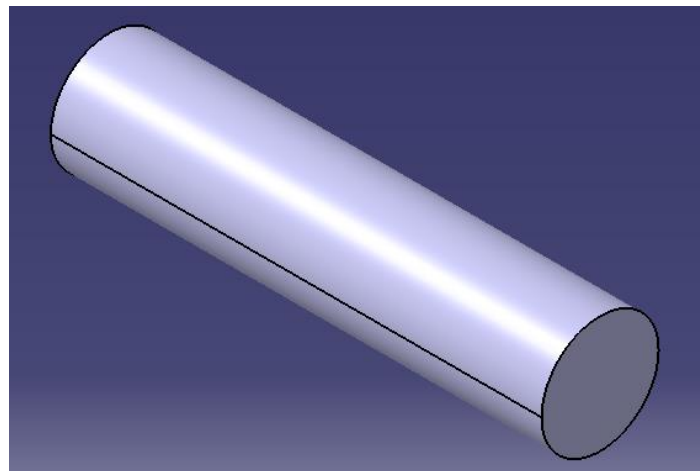

Figura 6. Lateral izquierdo

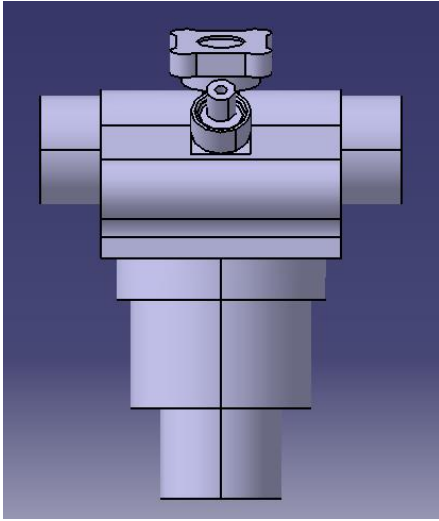

Figura 7. Planta

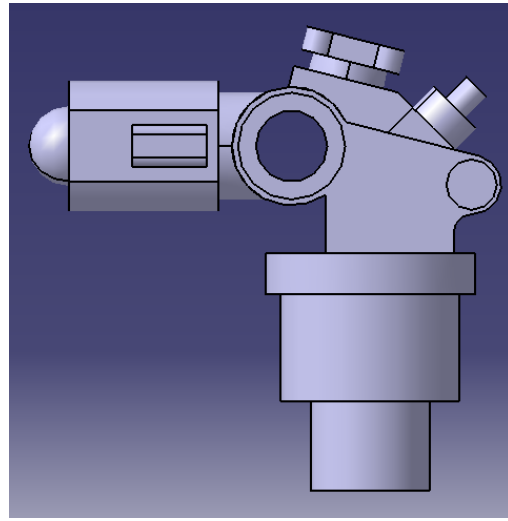

Figura 8. Isométrica

3. Pieza 3: Válvula de corte manual

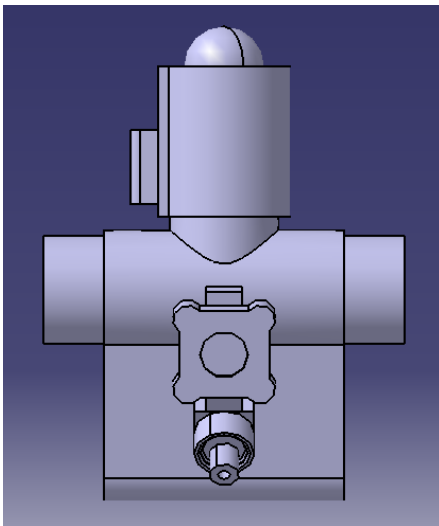

Figura 9. Alzado

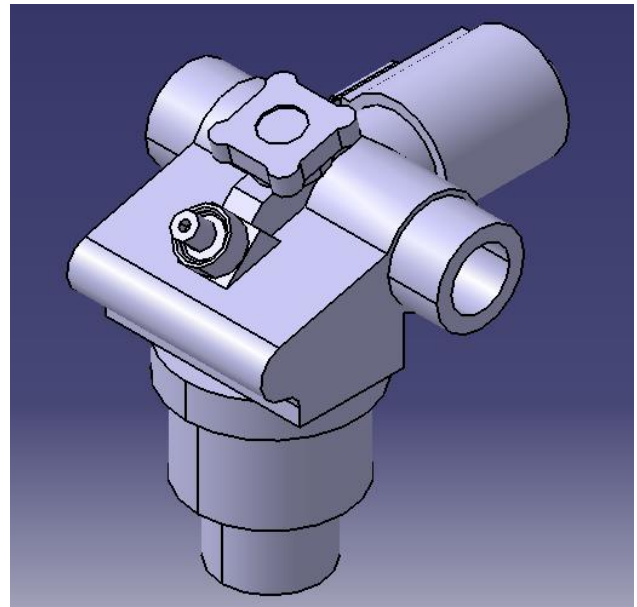

Figura 10. Lateral izquierdo

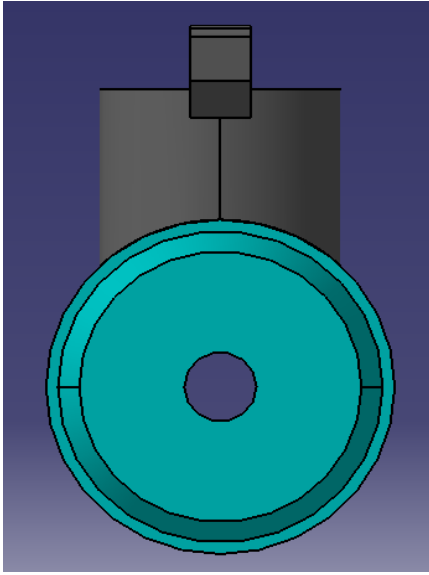

Figura 11. Planta

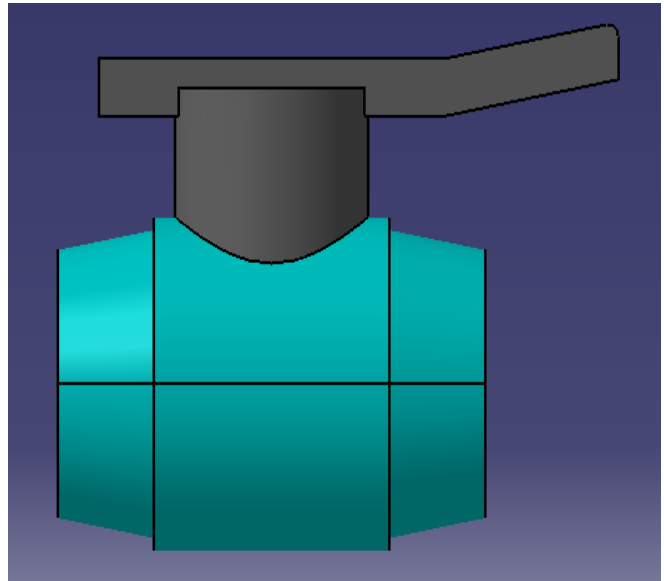

Figura 12. Isométrica

4. Pieza 4: Filtro de combustible

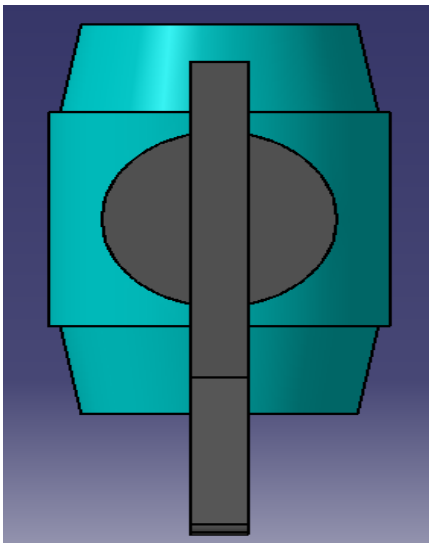

Figura 13. Alzado

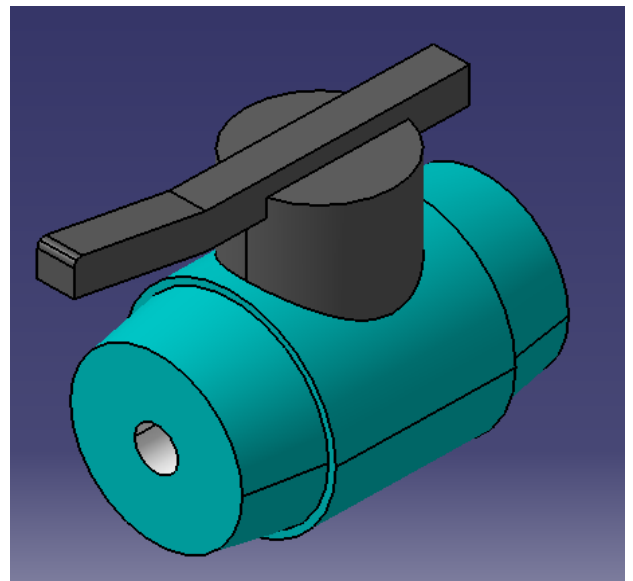

Figura 14. Lateral izquierdo

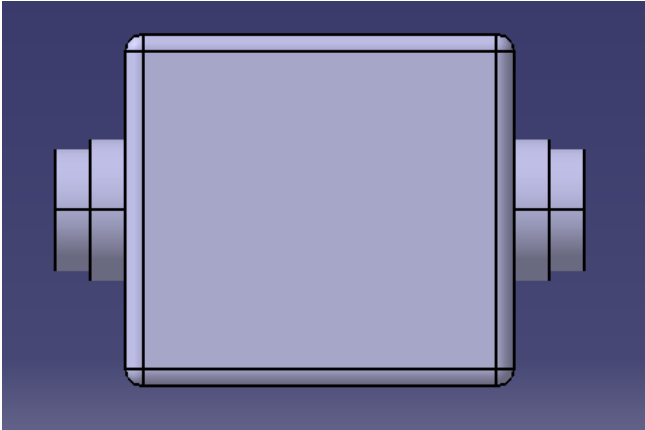

Figura 15. Planta

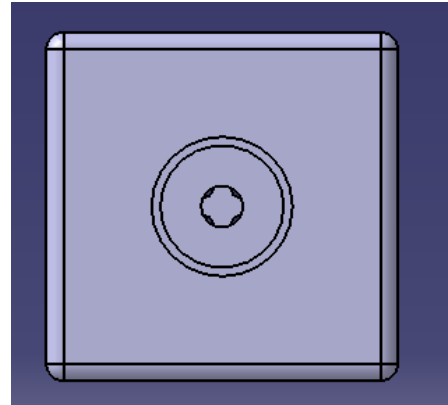

Figura 16. Isométrica

5. Pieza 5: Manómetro

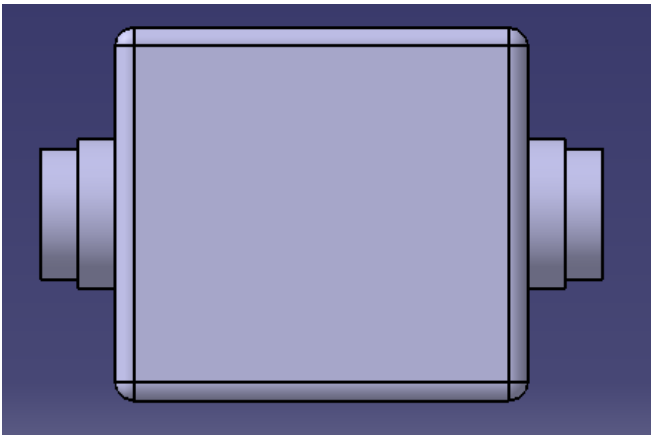

Figura 17. Alzado

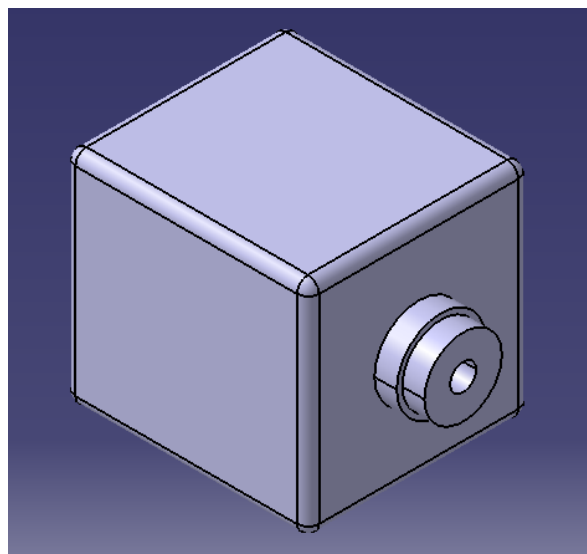

Figura 18. Lateral izquierdo

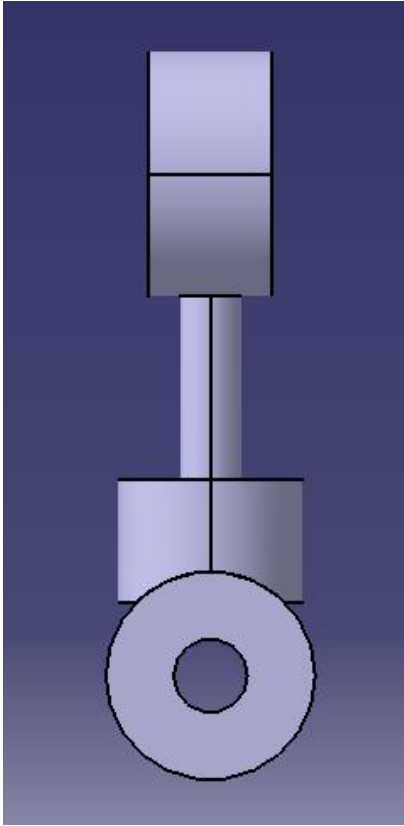

Figura 19. Planta

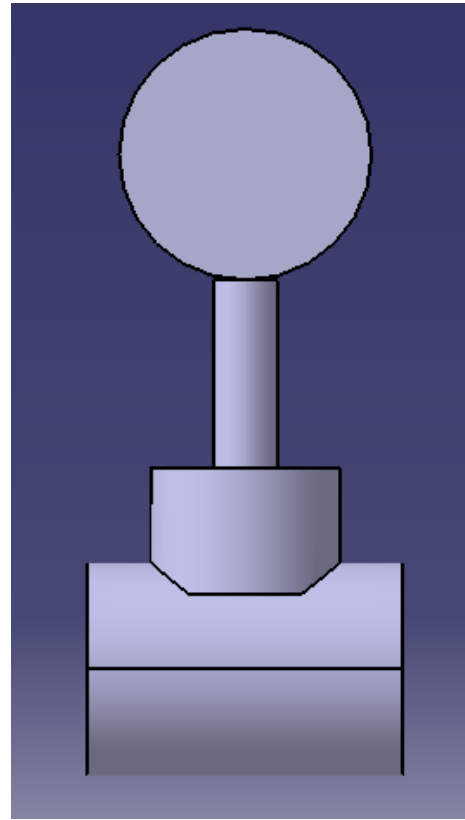

Figura 20. Isométrica

6. Pieza 6: Sensor de presión del depósito

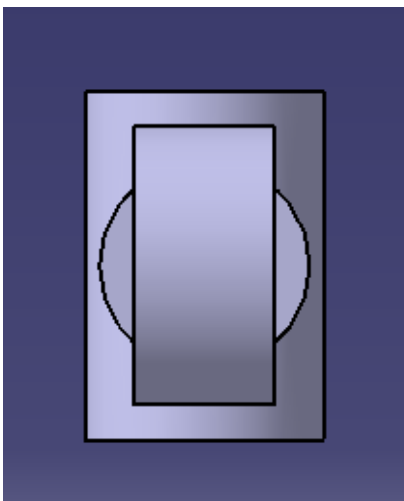

Figura 21. Alzado

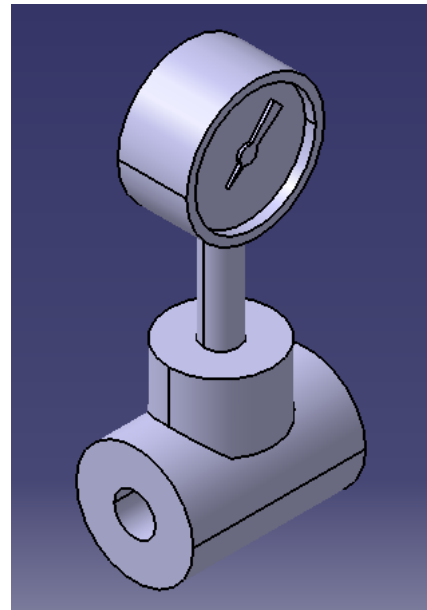

Figura 22. Lateral izquierdo

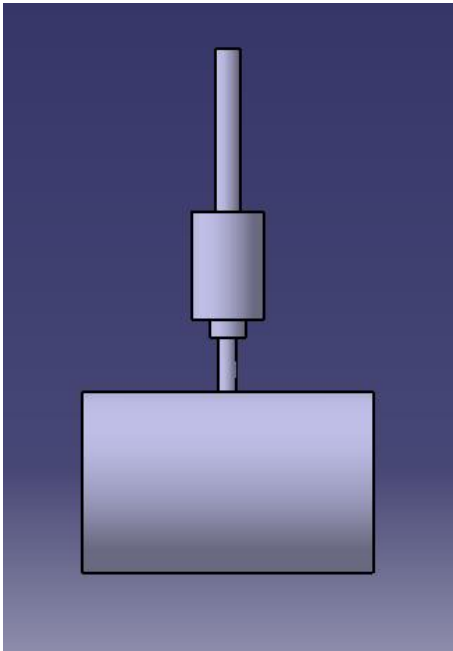

Figura 23. Planta

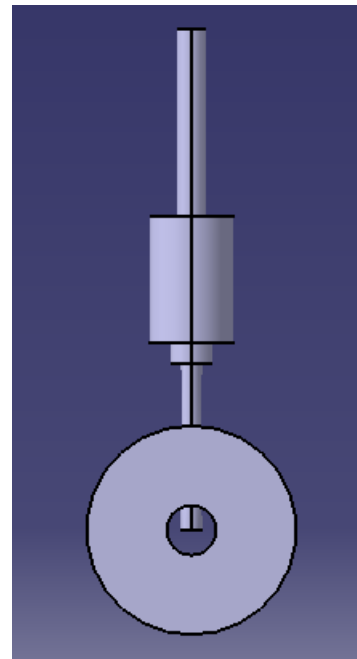

Figura 24. Isométrica

7. Pieza 7: Regulador de la presión del gas

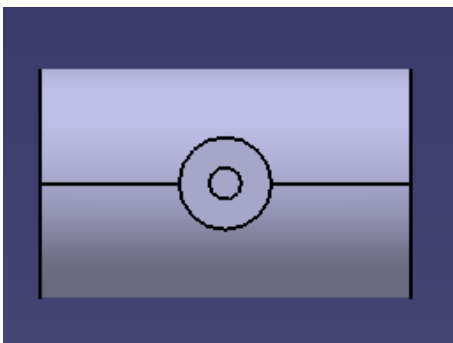

Figura 25. Alzado

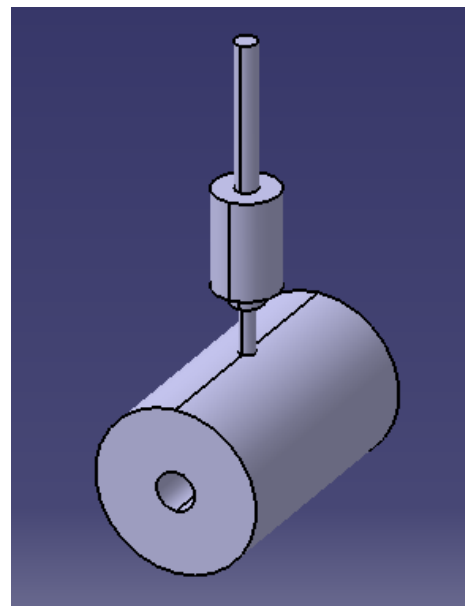

Figura 26. Lateral izquierdo

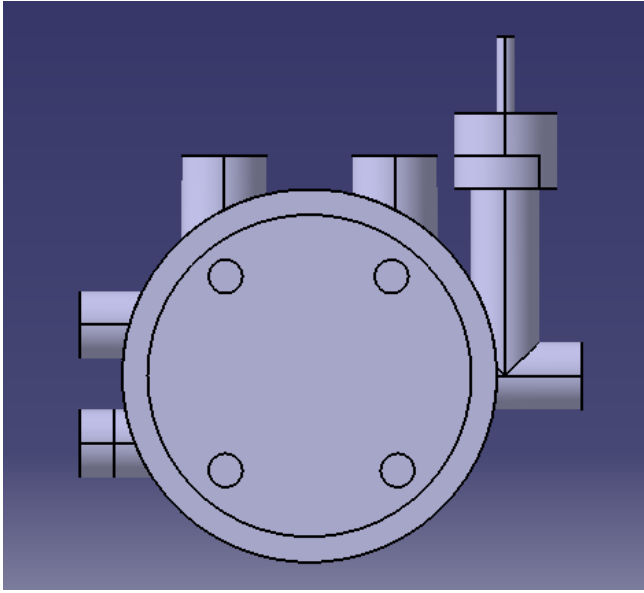

Figura 27. Planta

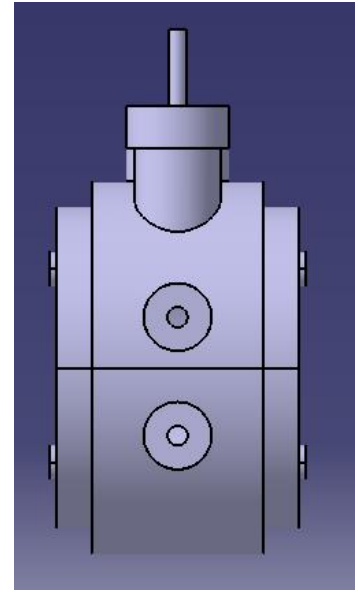

Figura 28. Isométrica

8. Pieza 8: Válvula de seguridad del regulador de gas

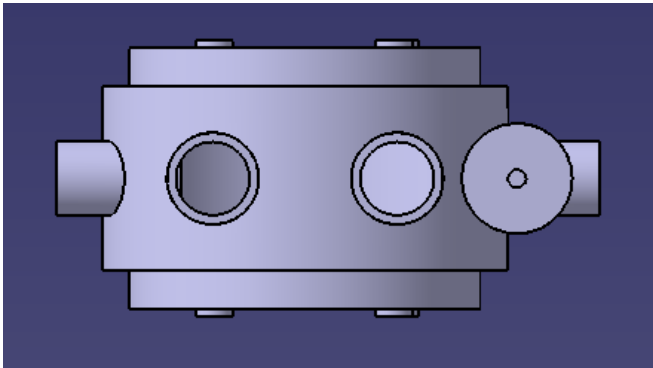

Figura 29. Alzado

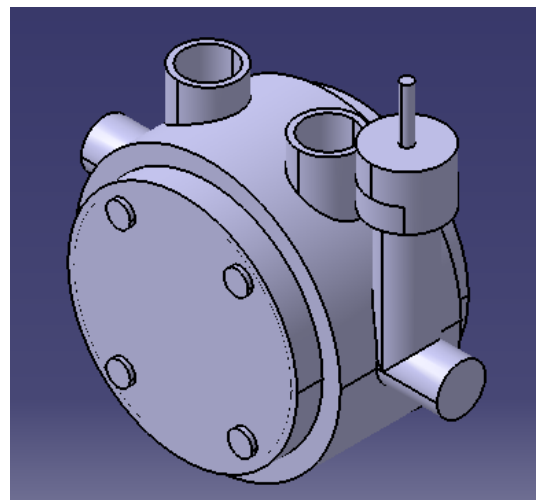

Figura 30. Lateral izquierdo

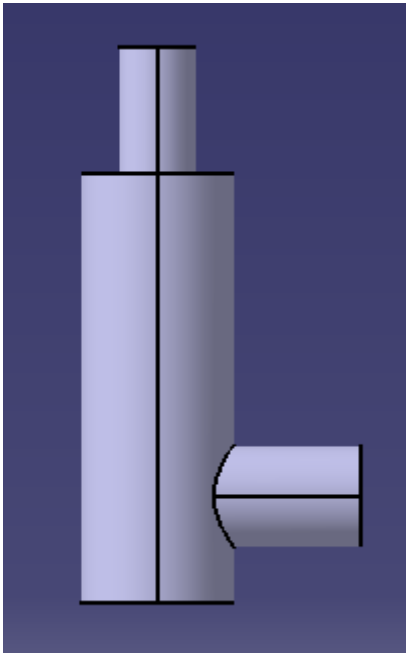

Figura 31. Planta

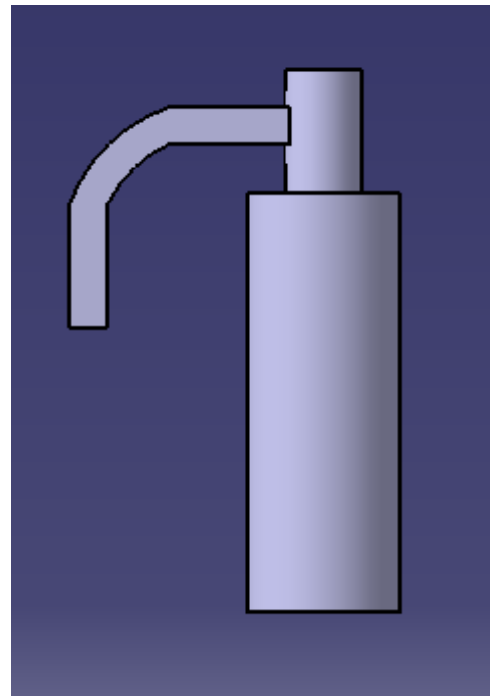

Figura 32. Isométrica

9. Pieza 9: Válvula solenoide de corte de gas, baja presión

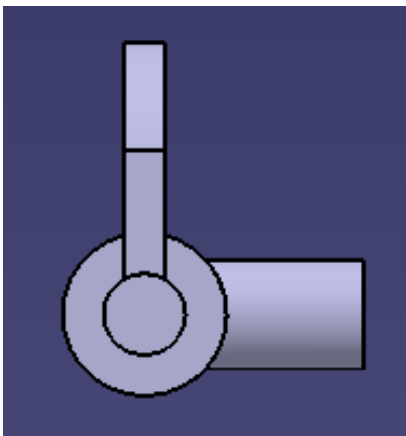

Figura 33. Alzado

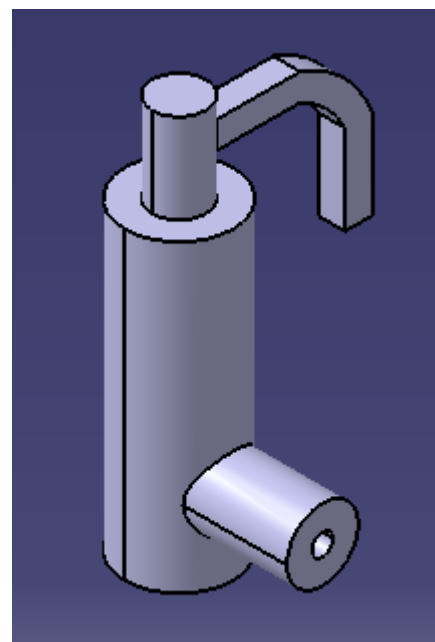

Figura 34. Lateral izquierdo

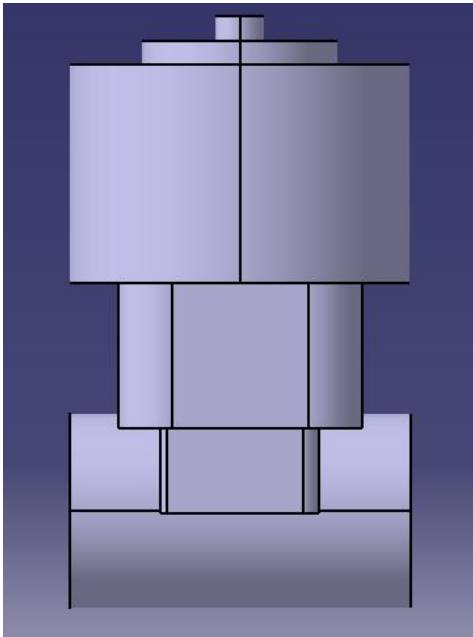

Figura 35. Planta

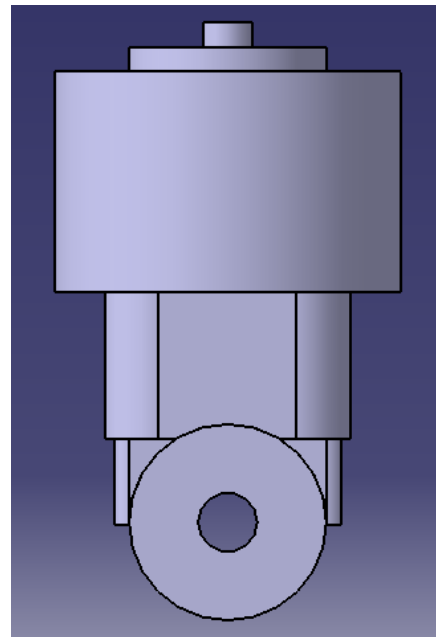

Figura 36. Isométrica

10. Piezas 10 y 11: Sensor de temperatura y presión del combustible en la rampa del combustible y rampa de combustible.

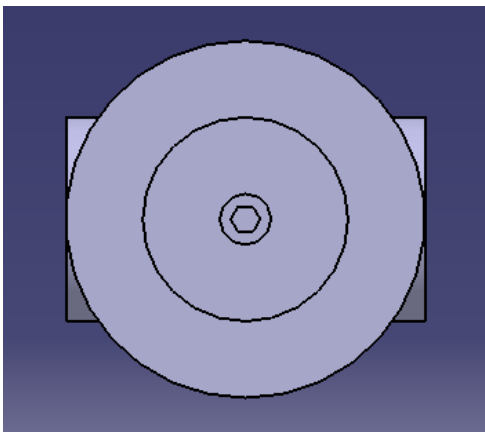

Figura 37. Alzado

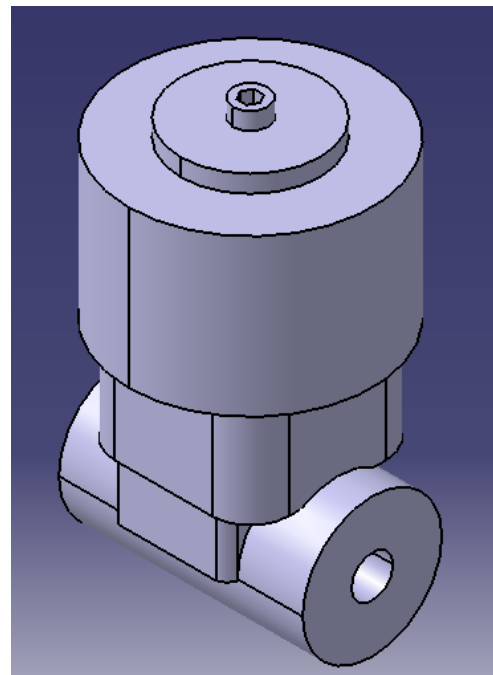

Figura 38. Lateral izquierdo



Figura 39. Planta

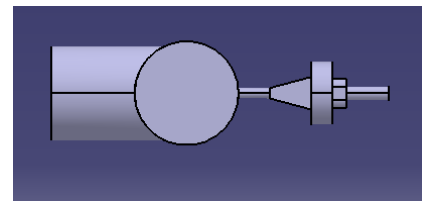

Figura 40. Isométrica

11. Pieza 12: Inyectores

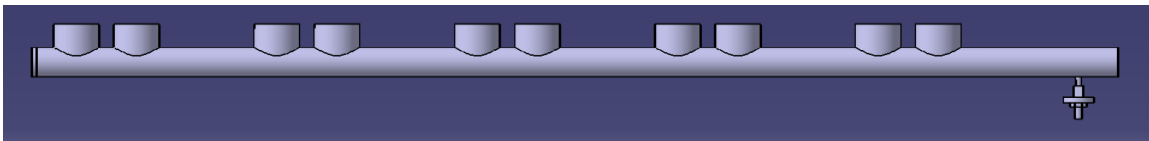

Figura 41. Alzado

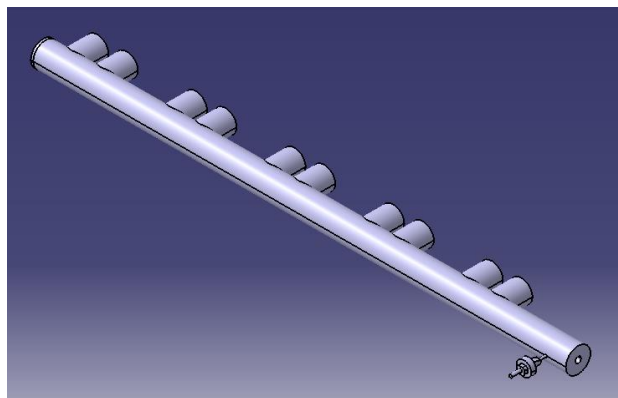

Figura 42. Lateral izquierdo

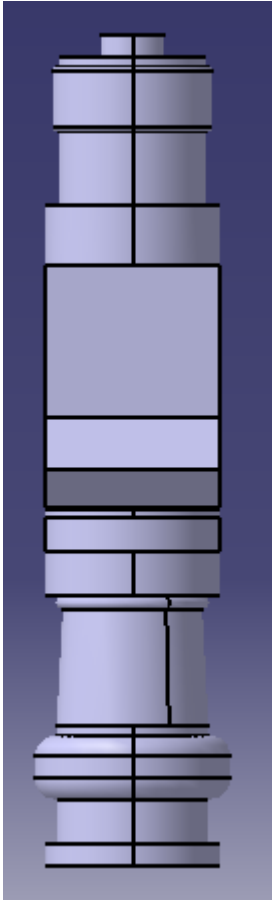

Figura 43. Planta

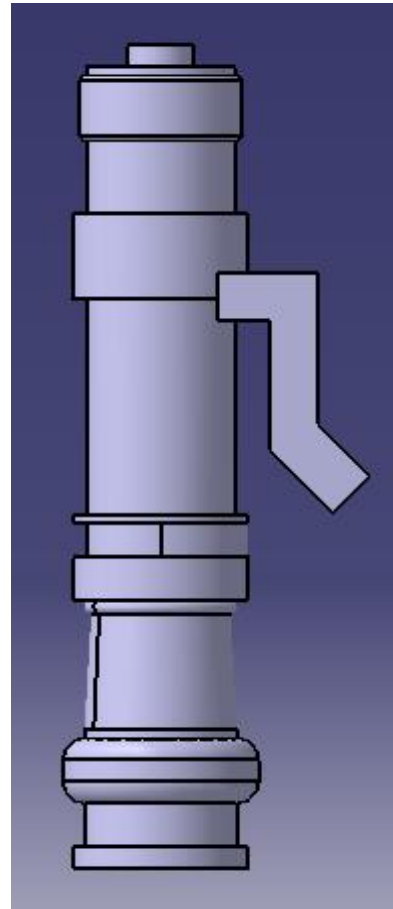
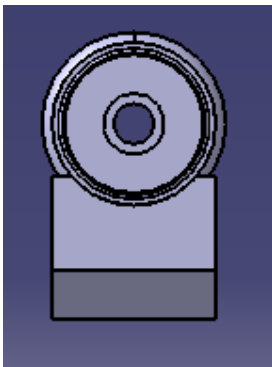
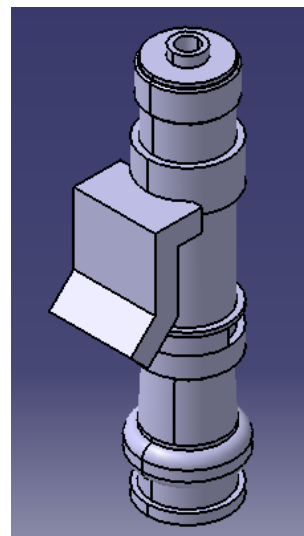

Imagen 44. Isométrica