

A low cost DSP-based control method for high frequency parallel resonant current-fed inverters

Guillermo Martín-Segura¹ Joaquim López-Mestre^{1,2} Héctor Rivas-Guerrero^{1,3}
Miquel Teixidó-Casas^{1,2}
Daniel Montesinos-Miracle¹

¹ Centre d'Innovació Tecnològica en Convertidors Estàtics i Accionaments (CITCEA-UPC)
Departament d'Enginyeria Elèctrica, Universitat de Catalunya,
ETS d'Enginyeria Industrial de Barcelona,
Av. Diagonal, 647, Pl. 2. 08028 Barcelona, Spain
E-mail: guillermo.martin@citcea.upc.edu
Phone: +34 (93) 413-7432
Fax: +34 (93) 401-7433
<http://www.citcea.upc.edu>

² Control Intel·ligent de l'Energia, SCCL (CINERGIA, SCCL)
C. Llull 51-55, 1er 2a 08005 Barcelona, Spain
E-mail: teixido@cinergia.coop
Phone: +34 93 401-6727
Fax: 34 93 401-7433
<http://www.cinergia.coop/>

³ Universidad Nacional Experimental del Táchira
Departamento de Ingeniería Electrónica
Av. Universidad, Sector Paramillo, San Cristóbal, Venezuela
E-mail: hrivas@unet.edu.ve
Phone: +58 (276) 353-0422
<http://www.unet.edu.ve>

July 28, 2009

Acknowledgments

This work has been supported by the *University and Research Commissioner of the Innovation, Universities and Enterprises Department of the Catalan Government* and the *European Social Fund*.

Keywords

<<Current source inverter (CSI)>> <<Converter control>> <<Resonant converter>>

Abstract

Nowadays the possibility to increase switching frequency in power converters has allowed minimizing their size and weight, and has permitted the improvement of their power density. This has been achieved by using soft-switching techniques that reduce the switching losses and the stress the switches suffer, quite of this techniques rely on resonance concept. However this increase of frequency is not exempt

of problems, and depending on the frequency it carries some problems in current sensing methods and in control precision. In order to solve these problems with an acceptable cost, a low-cost DSP-based control technique for current-fed parallel resonant inverters is presented. This technique uses gate signals as current measurement and the capture modules provided by most of microcontroller manufacturers. Such method decreases the cost, diminishes the analog components and its variability and improves the flexibility of the system. This technique is presented and applied to a 75 kHz and 6 kW prototype, obtaining favorable experimental results and demonstrating its feasibility.

Introduction

Increasing the switching frequency of switch mode converters is a common method for minimizing size and weight of inductors and transformers, and hence increase converters' power density and lower their cost. Taking into consideration that most of switching losses are produced during their commutation, to reach these frequencies the thermal stress of the switches should be reduced. This stress reduction is usually accomplished by using different topologies and switching strategies relying on zero-voltage and/or zero-current switching, which generally involves working in resonance, [1, pp.257].

Though there are many resonant topologies, the most basic ones are those based on load resonant converters with series or parallel tanks: current-fed parallel resonant inverter (CFPRI) and voltage-fed series resonant inverter (VFSRI), Figure 1. In case of VFSRI the V_{load} is a square wave and I_{load} is sinusoidal, while in the CFPRI is the other way round. In both cases resonance is reached by varying the switching frequency of the converter trying to minimize the phase shift between current and voltage. To accomplish that it is necessary to measure voltage and current at high frequencies, but the method to obtain these measurements and their phase shift in a precise and cheap manner could be difficult when having high power and high frequencies.

In the following sections the most common sensing methods for these applications as well as their control techniques will be introduced and discussed. In particular, a low-price control method for CFPRI will be presented. And this method will be applied to a 75 kHz and 6 kW prototype, obtaining favorable experimental results and demonstrating its feasibility.

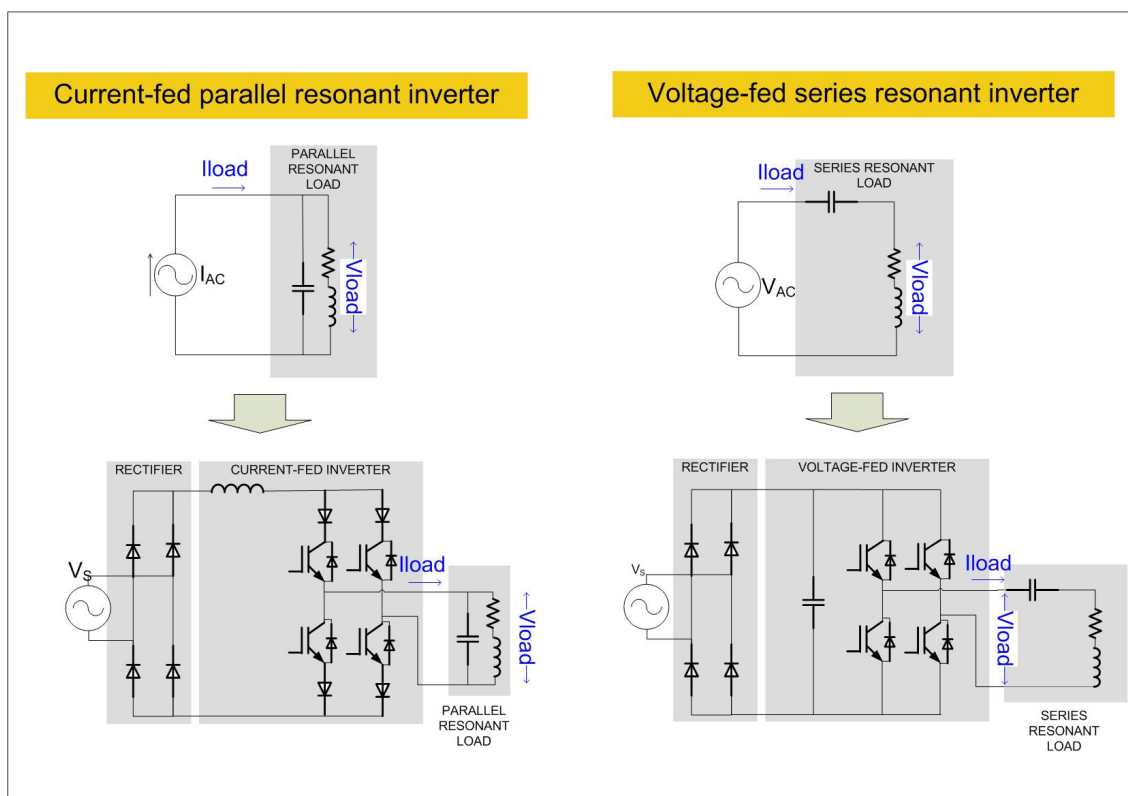

Figure 1: Current-fed parallel resonant inverter (CFPRI) and voltage-fed series resonant inverter (VFSRI)

Common current and voltage measuring techniques for high power and high frequency converters

There are various methods to obtain the current and voltage measurements to control resonant converters, but when using conventional sensing methods with high power and high frequency converters some characteristic problems appear, fact that could notably increase the price of the system. In the following paragraphs some common sensing methods are exposed:

- **Hall-effect transducers:** Most of high power converter manufacturers tend to use these voltage and current transducers due the isolation that provide, their cost and their simplicity. At high frequencies transducers based on Hall-effect could be damaged by undesirable heating produced by eddy currents induced on the transducer. In case of the voltage measuring this may not be so critical as the voltage is divided by a resistor, but in case of current measuring, due to the high magnetic fields within the transducer and the heat generated in them, it could be necessary to dimension 2 or 3 times their nominal value. When having high power converters measuring currents above 500A this problem could lead us to an important increase of price, and depending on the frequencies to the inexistence of such transducers. In case of the control system for CFPRI it is necessary to know current waveform, but in VFSRI a solution to this problem is to employ just voltage measurements to control the converter, [2] [3].
- **Shunt resistors:** One option to solve Hall-effect difficulties with current measurement is using shunt resistors to convert current to voltage measurements and then measure them with Hall-effect Transducers. The problem of using this technique at high power and high frequencies is that the phase delay caused by the parasitic inductance of shunt resistors is noticeable. This variable delay makes difficult to obtain precisely the angle between voltage and current. Very low-inductance and high power shunt resistors are needed to make a reliable measurement, but this kind of shunt resistors at high currents could be difficult to find, leading again to an increase of the price.

A solutions to reduce the cost is to pass just a part of the current through the shunt resistor and suppose that the distribution of the current is uniform in the rest of the wire. However there are few manufacturers of such powerful and low inductance shunt resistors (e.g. Newtons4th Ltd) and could be difficult and costly obtain them.

- **Rogowski current transducers:** Another solution is provided by Rogowski current transducer manufacturers. In this case the voltage induced in a Rogowski coil is proportional to the rate of change of the current enclosed by the coil, thus the transducers only measure AC currents. This solution is good enough to allow the control achieve the resonance, but to have better protections and more realistic measurements it is better having more than AC measurement. Anyway, it could be a good solution, although once again few manufacturers provide such coils (e.g. Power Electronic Measurements Ltd.) and the price increases notably.
- **Current transformers:** A similar concept to Rogowski transducers is offered by current transformers. As well as in the previous method, the transformer only measures AC currents but in this case there are more manufacturers of high power and high frequency current transformers (e.g. Sirio Inductive Components). Current and voltage transformers are found in some resonant converters, [4] [5].

A simple solution to decrease the cost is constructing the transformers themselves by using a toroid with some wire turns. In this case it has to be taken into account the toroid magnetic saturation and it is preferable having at least one Rogowski transducer to calibrate it correctly.

In this chapter some common methods to obtain current measurements and some economical solutions in case of high power and high frequency converters have been explained. If two of the best solutions among common current measuring techniques had to be chosen, one option would be using Rogowski transducers or current transformers (knowing just the AC components), and the other one would be passing a partial current through a current transducer or shunt resistor (knowing just a part of the real current).

In this context, this paper presents a low-cost control technique to sense the current taking profit of the inherent structure of the CFPRI . This technique consist in using switching gate signals as current measurement for controlling the converter ([4] [6] [7] [8] [9]).

Phase shift control schemes

In order to track the current and voltage to the resonant frequency by reducing to zero their phase-shift, converter designers usually make use of phase locked loop (PLL) schemes. Most of them use specific PLL integrated circuits ([2] [4] [6] [8] [10] [11] [12]), frequently based on the integrated circuit family 4046 ([2] [4] [6] [8] [11]).

In case of CFPRI, V_{load} is measured obtaining a square wave signal of the same frequency and passing this signal through an XOR gate with the I_{load} square wave signal to acquire their phase shift. Then a

proportional voltage to this phase shift is obtained thanks to a low pass filter and a voltage controlled oscillator that generates the gate signals to the switches. Some of the authors use current measurements to control the converter, Figure 2 ([2] [11] [12] [13]), and some of them use gate signals as current measurements, Figure 3 ([4] [6] [7] [8] [9]). In the second case some of them include a compensator to take into consideration the delays in the current waveform produced by the wiring, switching time of the transistors or logic delays.

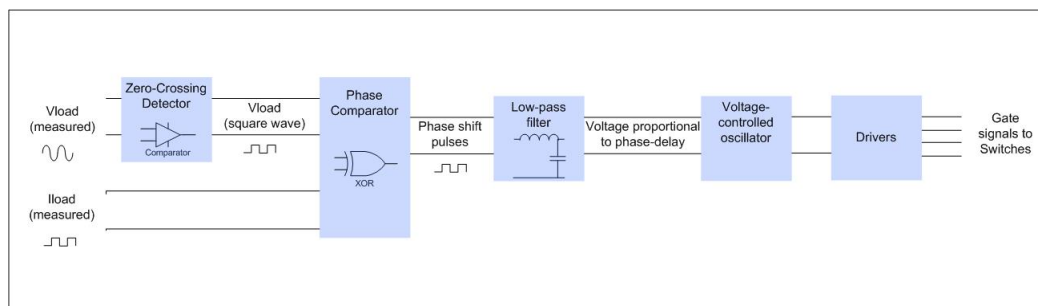

Figure 2: Block diagram of the control circuit with current measurement

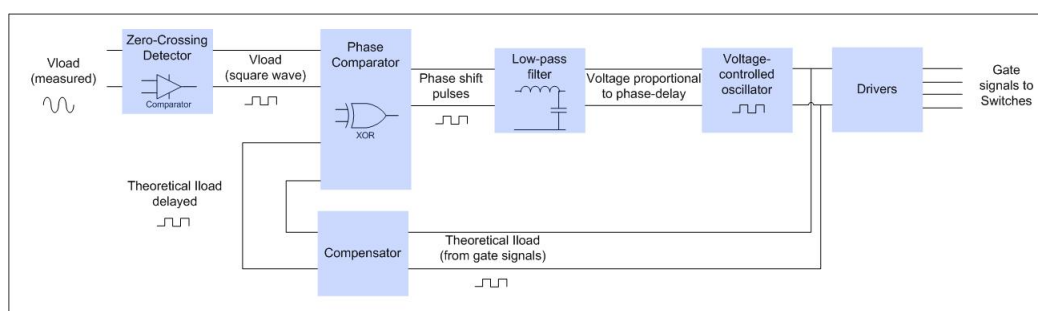

Figure 3: Block diagram of the control circuit with gate signals as a current measurement

Though most authors use commercial PLLs or similar analog logic schemes, few of them use microcontrollers like DSPs [3] [13] or FPGAs [7]. However, even those using microcontrollers tend to use similar schemes to Figures 2 and 3 but measuring the voltage proportional to the phase shift through their analog to digital converters and treating the signal. Thanks to the decrease of the analog components the variability of the control is diminished but some of the advantages of using such microcontrollers are not used.

This paper presents a DSP-based digital control approach taking profit of the peripherals provided by microcontroller manufacturers. This technique enables easy implementation and allows a more reliable, flexible and precise implementation. At the same time it limits the variation due to the usage of analogue components, which may change with time and temperature.

Proposed control system

Nowadays quite microcontroller manufacturers (e.g. Microchip, Infineon, Freescale, Texas Instruments) provide their microcontrollers with the capability to detect falling and rising edges of input signal, usually through a capture unit or module. As seen previously, in case of CFPRI and VFSRI the control system has to be able to maintain zero phase shift between current and voltage to achieve resonance under different circumstances. Regarding the considerations and limitations exposed before, the control scheme proposed in this paper takes profit of this capture module provided by microcontroller manufacturers.

This control method as compared with the usual ones (Figures 2 and 3) has the phase comparator, the low pass filter, the voltage controlled oscillator, the compensator and the proportional integral regulator joint in the microcontroller (Figure 4). The microcontroller detects the edges of two train pulses in phase with voltage and current, compares them and changes the switching frequency to achieve zero phase shifting. In addition this system uses gate signals as current measurement to decrease the cost of the system.

A simplified scheme of the implemented control system is shown in Figure 5. Both signals are introduced through the capture unit of the microcontroller and the instant at which their edges occur are detected and memorized. The phase shift error between them is calculated by subtracting the detected values and

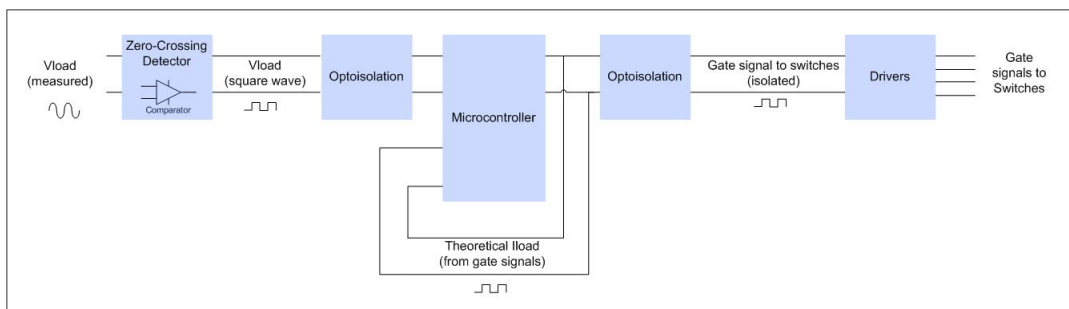

Figure 4: Block diagram of the control circuit proposed

ensuring it is smaller than the switching frequency. Then this phase shift error is minimized by changing the commutation frequency of the switches, increasing the frequency if the I_{load} delays V_{load} , and the contrary in the opposite case.

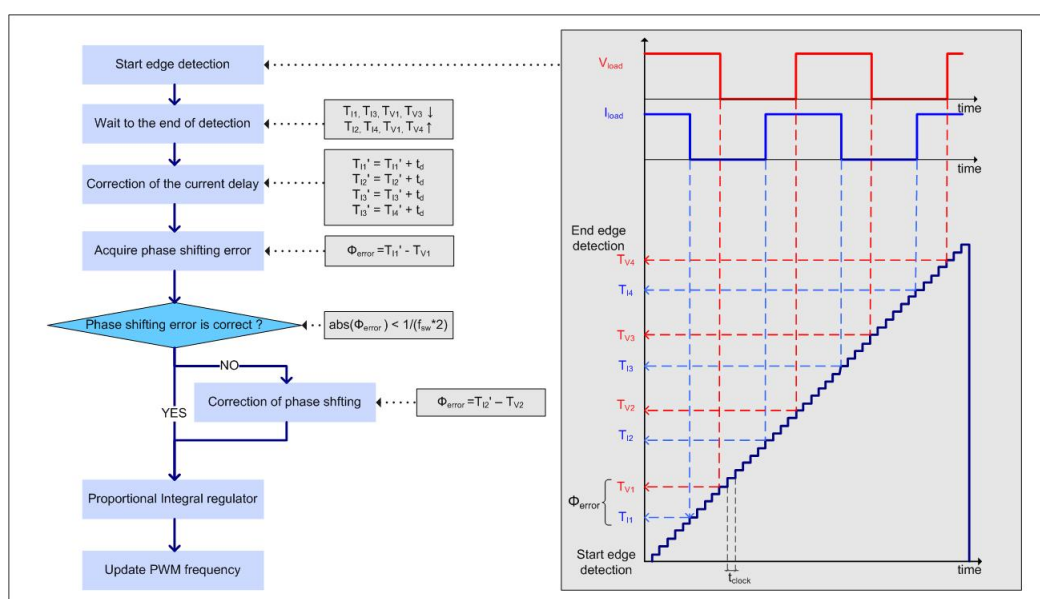

Figure 5: Control scheme implemented in the microcontroller

It has to be noted that in this paper a proportional integral regulator is chosen for its simplicity but other regulators could be used to improve the performance of the converter. It also has to be noted that the precision of this system will rely on the time clock of the microcontroller, thus it has to be taken in consideration when choosing it.

Control system implementation and experimental results

The microprocessor chosen to implement the control scheme has been a Digital Signal Processor TMS320F2808 from Texas Instruments because it integrates the peripherals needed, is flexible for re-programming, is fast treating digital signals and sturdy against perturbations. This DSP incorporates an enhanced capture module (eCAP module) with a 32-bit time base and 100 MHz system clock, with 4-event time-stamp registers (each of 32 bits) and with edge polarity selection. That module allows the implementation of the control scheme proposed in Figure 5 with high precision.

For the reasons exposed in previous sections to diminish the cost of the system, the train pulses to control the converter will be obtained from gate signals in case of current. In case of voltage they are obtained from a resistive divider with low inductance resistors and a zero-crossing detector with an operational amplifier. In order to isolate the voltage signal and avoid the effects of parasite wire inductances at high frequencies the voltage train pulses have been optoisolated with optical fiber.

This capture module-based control technique has been applied to a 75 kHz and 6 kW prototype. In Figure 6 it can be observed how the converter is working in resonance at 66 kHz (V_{load} and I_{load} without phase shift). It can also be noted the delay between the real current (I_{load}) and the *Theoretical* I_{load} obtained

from gate signals. In this case the time delay has been fixed, obtaining good results after some empirical experience for continuous conditions.

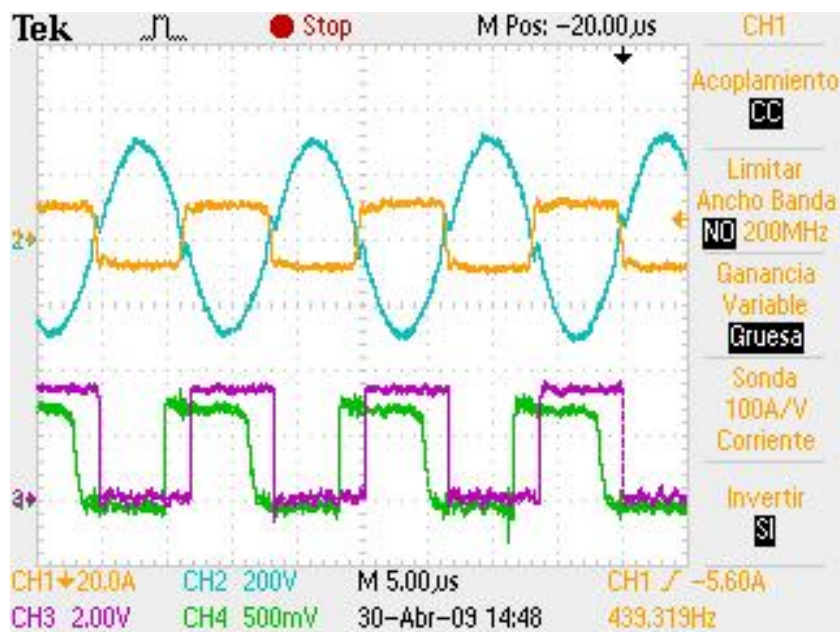

Figure 6: Experimental results at 66kHz (V_{load} in blue, I_{load} in yellow, $Theoretical I_{load}$ from gate signal in green and $Mesured I_{load}$ from a toroid in violet)

Though the time delay variation is not really significant, in case of having quite varying working conditions or in continuous processes it is necessary to adjust the $Theoretical I_{load}$ time delay. This could be done manually as a periodic maintenance routine, but a better solution is to measure the current instead of taking an approximation. As explained in previous sections, in high power and frequency converters the measurement has some difficulties, but a simple and cost effective solution is constructing a current transformer ourselves and use a zero-crossing detector similar to the one used in voltage measurement. The measured current waveform obtained in such system is depicted in Figure 6 as $Mesured I_{load}$. It could be observed how this signal has much less delay than the $Theoretical I_{load}$, acquiring a more flexible and reliable solution with little investment.

Conclusions

In the present paper some common sensing methods for high power and high frequency converters have been exposed, and some usual control techniques for resonant converters have been explained. A low-cost method for CFPRI consisting in the use of the compare unit provided by most of microcontroller manufacturers and the gate signals as current sensors has been presented. This method has been implemented in a 75 kHz and 6 kW prototype and the experimental results obtained have been favorable, demonstrating its feasibility. Even though the system proposed is satisfactory, a cheap and simple improvement using a toroid as a current sensor has been exposed. This system solves the problem with the variation of the time delay between the gate signal and the real current with little cost.

References

- [1] N. Mohan, T. M. Underland, and W. P. Robbins, *Power electronics. Converters, Applications and Design*, second edition ed. John Wiley & Sons, inc., 1995.
- [2] A. Okuno, M. Hayashi, H. Kawano, H. Yasutsune, and M. Nakaoka, "Series resonant frequency tracking-based high-frequency inverter using static induction power transistors for electromagnetic industrial induction metal surface heating and feasible evaluations," in *Proc. International Conference on Power Electronics and Drive Systems*, 1995, pp. 212–217 vol.1.
- [3] N. S. Bayindir, O. Kukrer, and M. Yakup, "Dsp-based pll-controlled 50-100 khz 20 kw high-frequency induction heating system for surface hardening and welding applications," *IEE Proceedings -Electric Power Applications*, vol. 150, no. 3, pp. 365–371, 2003.

- [4] H. Sheng, Y. Pei, X. Yang, F. Wang, and C. W. Tipton, "Frequency tracking control for a capacitor-charging parallel resonant converter with phase-locked loop," in *Proc. APEC 2007 - Twenty Second Annual IEEE Applied Power Electronics Conference*, 2007, pp. 1287–1292.
- [5] E. J. Dede, J. Jordan, V. Esteve, J. M. Espi, and S. Casan, "Series and parallel resonant inverters for induction heating under short-circuit conditions considering parasitic components," in *Proc. IEEE 1999 International Conference on Power Electronics and Drive Systems PEDS '99*, vol. 2, 1999, pp. 659–662 vol.2.
- [6] S. Chudjuarjeen, C. Koumpai, and V. Monyakul, "Full-bridge current-fed inverter with automatic frequency control for forging application," in *Proc. TENCON 2004. 2004 IEEE Region 10 Conference*, vol. D, 2004, pp. 128–131 Vol. 4.
- [7] J. Tian, J. Petzoldt, T. Reimann, M. Scherf, and G. Berger, "Control system analysis and design of a resonant inverter with the variable frequency variable duty cycle scheme," in *Proc. 37th IEEE Power Electronics Specialists Conference PESC '06*, 2006, pp. 1–5.
- [8] I. Khan, J. Tapson, and I. De Vries, "Automatic frequency control of an induction furnace," in *Proc. IEEE AFRICON*, vol. 2, 1999, pp. 913–916 vol.2.
- [9] E. J. Dede, J. V. Gonzalez, J. A. Linares, J. Jordan, D. Ramirez, and P. Rueda, "25-kw/50-khz generator for induction heating," *IEEE Trans. Ind. Electron.*, vol. 38, no. 3, pp. 203–209, 1991.
- [10] I. Khan, J. Tapson, and I. de Vries, "Frequency control of a current-fed inverter for induction heating," in *Proc. IEEE International Symposium on Industrial Electronics ISIE 2000*, vol. 1, 2000, pp. 343–346 vol.1.
- [11] M.-P. Chen, J.-K. Chen, K. Murata, M. Nakahara, and K. Harada, "Surge analysis of induction heating power supply with pll," *IEEE Trans. Power Electron.*, vol. 16, no. 5, pp. 702–709, 2001.
- [12] A. Okuno, M. Hayashi, H. Kawano, H. Yasutsune, E. Hiraki, and M. Nakaoka, "Phase-lock loop operated load-resonance inverter using static induction power transistors and its practical characteristic evaluations," in *Proc. International IEEE/IAS Conference on Industrial Automation and Control: Emerging Technologies*, 1995, pp. 1–7.
- [13] Y.-L. Cui, K. He, Z.-W. Fan, and H.-L. Fan, "Study on dsp-based pll-controlled superaudio induction heating power supply simulation," in *Proc. International Conference on Machine Learning and Cybernetics*, vol. 2, 2005, pp. 1082–1087 Vol. 2.