

REF. CANT.	DESIGNACIÓ	LIBERIA QUANTITZAD		CARACT. TECNICS
		LONGITUD (m)	ALÇADA	
01	1	2102	1460	Wassermann
02	1	332	194	Sedical
03	1	227	194	Sedical
04	2	227	194	Sedical
05	1	332	194	Sedical
06	2	1126	535	Dublin
07	8	1336	535	Dublin
08	9	1336	535	Dublin
09	1	3250	2310	Arcan
10	1	2450	2350	Dellino
11	2	1790	870	Melon
12	2	600	505	SAP
13	10	600	513	Sedical
14	1			Sedical
15	1			Sedical
16	1			Sedical
17	1			Sedical
18	1			Sedical
19	1			Sedical
20	1			Sedical
21	1			Sedical
22	1			Sedical
23	1			Sedical
24	1			Sedical
25	30			Wassermann
26	1			Lepaco
27	1			Lepaco
28	1			SAP
29	1			SAP
30	4			SAP
31	2			SAP
32	1			SAP
33	1			SAP
34	2			SAP
35	60			Schicko
36	27			Schicko
37	13			Schicko
38	2			Schicko
39	2			Schicko
40	1			Schicko
41	2			Schicko
42	17			Schicko

LEGENDA

- VALVULA DE SEGURIDAD CON VACUO
- FILTRO
- VALVULO ANTIBOMBEO
- FLEDO
- MANIVELTIO
- BOMBA
- BOMBA DE RECIRCULACION DOBLE
- VALVULA DE BOLA
- VALVULA DE EQUILIBRIO
- VALVULA DE RETENCION
- VASO DE EXPANSION
- TERMOMETRO
- INTERRUPTOR DE FLUIDO
- SONDIA TEMPERATURA AMBIENTAL
- VALVULA TEMPOSTATICA MEZCLADORA
- LINEA FRIGORIFICA
- TUBERIA ACERO CALEFACCION

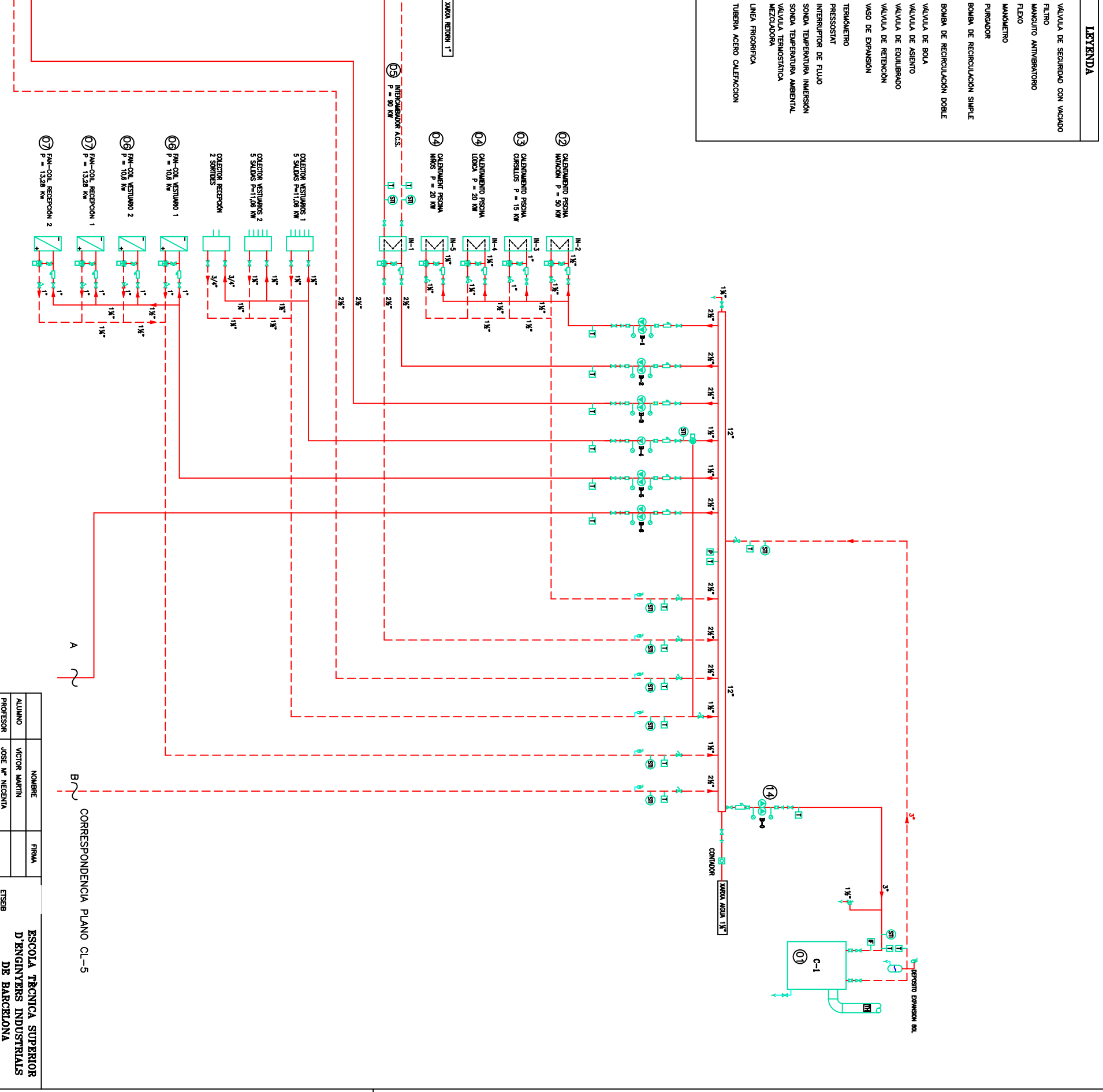
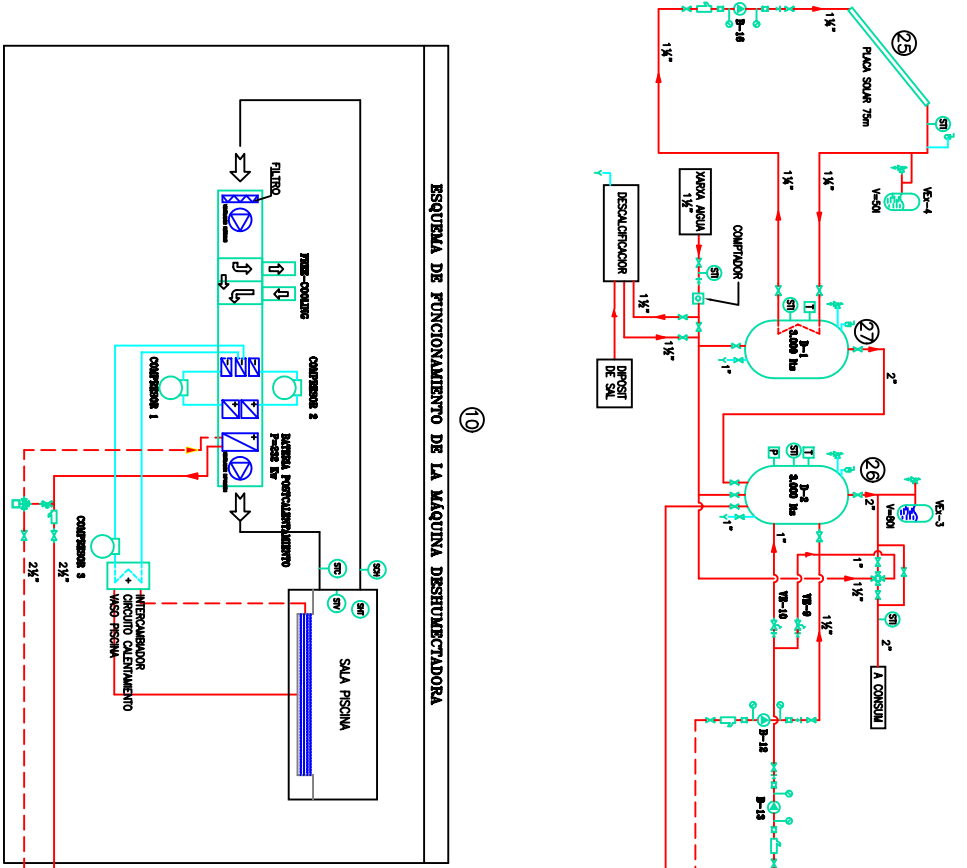

ALUMNO	VICTOR MARTIN	ESCOLA	S/E
PROFESOR	JOSE M. NECENYA	PLANO N.º:	PEC/CL-004
OBRA:	PISCINA PÚBLICA CENTRO DEPORTIVO DE BARCELONA	DESIGNACION:	ESQUEMA DE PRINCIPIO INSTALACION CLIMATIZACION
ESCOLA	ESCOLA TÉCNICA SUPERIOR D'ENGINYERS INDUSTRIALS DE BARCELONA	CAO:	REDACTADO OR:
S/E		HOLA N.º	de

CORRESPONDENCIA PLANO CL-5