



Escola Politècnica Superior
de Castelldefels

UNIVERSITAT POLITÈCNICA DE CATALUNYA



TAMPERE UNIVERSITY
OF APPLIED SCIENCES

Final Thesis

Title: Digital TV: Fixed and mobile systems

Author: Marcos Tejedor Alonso

Director: Ari Rantala

Date: 25th May 2010

Title: Digital Television: Fixed and mobile systems.

Author: Marcos Tejedor Alonso

Director: Ari Rantala

Date: 25th May 2010

Abstract

The Digital TV is already a part of our daily lives. There are different systems that make possible to bring it to our homes. These systems were developing by the DVB-Project Group. The most important are DVB-T (terrestrial), DVB-C (cable) and DVB-S (satellite). Even so and due to the changing needs of users in the field of communications and entertainment, there are new challenges that the current standards are not able to satisfy. Therefore becomes necessary to revise the current standards of DVB.

One of these new necessities are the mobile entertainment. The large increase in mobile phones and hand-held terminals in the society and the improvements in content distribution raised the need to bring it to these devices. As a result was created the DVB-H, a standard that allows you to download content for mobile devices, allowing greater mobility and a battery saving 90% if compared with its counterpart in DVB-T.

DVB-H is a standard that makes it possible to deliver live broadcast television to hand-held terminals. It is developed from the DVB-T standard, which makes it possible to send DVB-H signals in the DVB-H/T frequency band 470-862 MHz. This allows the benefit to reuse the DVB-T transmission equipment. Although this one, there are some differences between DVB-H and DVB-T as some process that are added to improve the features for a mobile terminal in the DVB-H standard. The most important additions are the time slicing, in order to reduce the average power consumption and MPE-FEC for improving Doppler performance and tolerance against interference.

Title: Digital Television: Fixed and mobile systems.

Author: Marcos Tejedor Alonso

Director: Ari Rantala

Date: 25th May 2010

Resumen

La televisión digital forma parte de nuestra vida diaria. Actualmente, existen varias posibilidades para llevarla a nuestros hogares. Estos sistemas fueron desarrollados por el grupo DVB-Project donde cabe destacar los más importantes entre los que se encuentran los estándares DVB-T (terrestre), DVB-C (cable), DVB-S (a través de satélite).

Aún con esto, las necesidades de los usuarios se encuentran en constante evolución tanto en el campo de las comunicaciones como en el del entretenimiento. Por esta razón existen nuevos retos que los estándares actuales no son capaces de satisfacer. Es más, hace necesaria una constante revisión de los estándares DVB.

Una de estas necesidades es el entretenimiento móvil. El gran incremento de estos terminales, y de otros sistemas móviles, en nuestra sociedad y las mejoras en los contenidos de distribución, hizo crecer la necesidad de poder acercar este nuevo entretenimiento (TV, descargas de aplicaciones) a estos terminales. Como resultado se creó el estándar DVB-H, un estándar que permite la descarga de contenidos para equipos móviles, permitiendo un ahorro en batería cercano al 90 % si se compara con su homólogo DVB-T.

El estándar DVB-H hace posible la reproducción de televisión en vivo en terminales móviles. Este fue desarrollado a partir del estándar DVB-T, haciendo posible enviar señales DVB-H en la banda de frecuencias usada hasta ese momento por sistemas DVB-T (470-862MHz). Esto permite un gran beneficio debido a que es posible el aprovechamiento de equipos de transmisión DVB-T. Aún así, existen algunas diferencias entre los dos sistemas, como algunos procesos que son añadidos para poder mejorar la calidad en terminales móviles usando el estándar DVB-H.

Las mejoras más importantes introducidas por el sistema son el "Time Slicing", que reduce el consumo de batería, y el "MPE-FEC" para mejorar la aparición del efecto Doppler y la tolerancia del sistema frente a interferencias.

Acknowledgements

This Final Thesis represents my final thesis at the Bachelor Degree in Telecommunication's Engineering at the EPSC (Escola Politècnica Superior de Castelldefels).

To start I would like to thank to my university in Tampere, where I'm doing the Erasmus, specially to my tutor Ari Rantala and to all the International Office to make me feel like at home.

I also would like to thank to all the people that I met in Tampere and to make me better as a person and to all the things that I learnt of them.

Finally to my home university at Castelldefels (EPSC) and my family, that without their support this would be impossible and to all my friends in Barcelona to encourage me to live this unforgettable experience.

Abbreviations

ADT	Application Data Table
BCH	Bose - Chaudhuri - Hocquenghem code
BER	Bit Error Rate
CCI	Co-Channel Interference
COFM	Coded Orthogonal Frequency Multiplexing
DAB	Digital Audio Broadcasting
DFT	Discrete Fourier Transform
DMB	Digital Multimedia Broadcasting
DVB	Digital Video Broadcasting
DVB-H	Digital Video Broadcasting- Hand-held
DVB-T	Digital Video Broadcasting-Terrestrial
DVB-S	Digital Video Broadcasting-Satellite
DTTB	Digital Terrestrial Television Broadcasting
ELG	European Launching Group
ETSI	European Telecommunications Standards Institute
FFT	Fast Fourier Transform
HDTV	High Definition TV
IRD	Integrated Receiver Decoder
ISI	Inter-Symbol Interference
LNB	Low Noise Block
MBMS	Mobile Broadcast/Multicast Service
MFN	Multi-Frequency Network
MHP	Multi Home Platform
MoU	Memorandum of Understanding
MPE-FEC	Multi-Protocol Encapsulation-Forward Error Correction
OFDM	Orthogonal Frequency Division Multiplex
OSI	Open Systems Interconnected)RF
RS	Reed-Solomon
SDMB	Satellite-Digital Mobile Broadcast
SD	Standard Definition
SFN	Single Frequency Network
TPS	Transmission Parameter Signalling
Ts	Transport Stream

LIST OF CONTENTS

CHAPTER 1. INTRODUCTION TO DIGITAL TV.....	13
1.1 The digitization process.....	13
1.2. Digital TV.....	13
CHAPTER 2. THE DVB-PROJECT AND STANDARDIZATION.....	15
2.1.The DVB-Project Group.....	15
2.2. DVB-Project: The emergence of the standards.....	15
2.3. Implementation of the standards in the countries.....	16
2.4. Recent research.....	17
2.5. European Telecommunications Standards Institute (ETSI).....	17
CHAPTER 3. BASIC STANDARDS ON DIGITAL TV.....	19
3.1. Digital Video Broadcasting by Satellite (DVB-S).....	19
3.1.1. Source coding and multiplex.....	20
3.1.2. Channel encoding and multiplex.....	21
3.1.3. Block of reception.....	21
3.1.4. The evolution of DVB-S: DVB-S2.....	22
3.2. Digital Video Broadcasting by Cable (DVB-C).....	22
3.2.1. Characteristics.....	23
3.2.2. The evolution of DVC: DVB-C2.....	24
3.3. Terrestrial Digital Video Broadcasting (DVB-T).....	24
3.3.1. Source Coding.....	25
3.3.2. Channel Coding.....	26
3.3.3. OFDM technique.....	28
3.3.4. COFDM.....	30

3.3.5. Single Frequency Network (SFN).....	30
3.3.6. Guard interval.....	31
3.3.7. Hierarchical and non-hierarchical modulation.....	33
3.3.8. Reception.....	34
3.3.9. Evolution of DVB-T : DVB-T2.....	35

CHAPTER 4. DIGITAL TV ON MOBILE DEVICES.....36

4.1. Mobile Digital TV Standard: DVB-H.....36

4.1.1. Time-Slicing.....	38
4.1.2. Multi Protocol Encap., Forward Error Correction (MPE-FEC).....	39
4.1.3. 4k mode and interleave.....	39
4.1.4. Transmission Parameter Signalling.....	41
4.1.5. Coverage Classes.....	32
4.1.6. Band Frequency of DVB-H.....	42
4.1.7. Building Penetration Loss.....	43
4.1.8. IP (Internet Protocol) in DVB-H system.....	44
4.1.9. Competing standards.....	46

CHAPTER 5. CONCLUSIONS.....48

CHAPTER 6. BIBLIOGRAPHY.....51

CHAPTER 1. INTRODUCTION TO DIGITAL TV

1.1 The digitization process

In the beginning of the 80's the digital era started and a lot of companies began to develop digital systems. One of the main challenges was to the digitization of television. This one was divided in two different parts. On one side was the digitization of production and on the other side the digitization of transmission.

The digitization of production developed many systems. The first one were based on digitizing composite video signal without success. The video signal is composed by luminance and colour difference and digitization of each signal separately of the other was the most suitable.

It was originally developed signaling the signals in parallel, with thick cables that needed one for each bit, but was soon replaced by the time multiplexed transmission of each of the signal's components. This system also allowed to include audio, included in the information that is transmitted, and other utilities that make it perfect to develop the digital TV.

Another challenge was the maintenance of the quality needed for TV production that is higher than the transmission. For this reason was developed the Studio Quality standard CCIR-601. Also appears standards for another fields that were less demanding (electronic news and light production).

The difference between the production quality in the studio and the fields less demanding is in the binary stream generated in the digitization of the signals, that is more higher in the first one.

The reduction of bits that were needed allowed to use algorithms, all based on discrete cosine transform used in the spatial and time domain, that reduced the flow making possible the construction of more affordable equipment . This opened the way for the small production companies and TV broadcasting and was the rise of local television.

For the transmission, digitization was possible by compression techniques that succeeded in reducing the flow from 270Mbit/s (original flow of a studio quality) to less than 5 Mbit/s. This compression is called MPEG-2 and produced streams between 4 and 6 Mbit/s without significant losses. [1]

1.2 Digital TV

Digital TV transmissions have three big areas depending on the type of technology that is used. The principals are transmission by satellite, terrestrial and cable radio, this last one is known as DTTV. The advances in computing, hardware and software, led to produce systems based on computer processing of the television signal. Storage systems that were used until then, became replaced by video and computer servers and, to store files, the information was passed on hard drives and data tapes.

Digital television (DTV) covers all the technologies of transmission and reception of images and sound through digital signals. In contrast to traditional TV, which encodes the data in analogue, digital television signals encodes in binary form, making possible ways between user and producer of content, creating, in such a way, interactive applications and the ability to transmit multiple signals on the same channel.

The digital television is composed by different elements as digital video cameras that work at resolutions much higher than analogue cameras, digital transmission and reception, high resolution...

Digital TV supports multiple transmission formats, different resolutions, allowing TV producers to create sub-channels of transmission. The following table shows the multiple formats that already exists [2]:

Table 1.1. Formats of Digital TV

Format	Image measures	Frames displayed
480i	720x480 pixels	60 interlaced frames x second => 30 complete frames x second
480p	720x480 pixels	60 full frames per second
576i	720x576 pixels	50 interlaced frames x second => 25 complete frames x second
576p	720x576 pixels	50 full frames x second
720p	1280x720 pixels	60 complete frames x second
1080i	1920x1080 pixels	60 interlaced frames x second => 30 complete frames x second
1080p	1920x1080 pixels	60 complete frames x second

The formats 480i, 480p, 576i and 576p are known as Standard Definition (SD). High Definition TV (HDTV) is formed by formats as 720p, 1080i and 1080p. Some companies have named "FULL HD" to refer exclusively to 1080i and 1080p, but this is only for commercial purposes.

Due to the MPEG-2 compression, a TV channel can choose to transmit a single HDTV program or multiple Standard Definition programs. DTV channels have the same bandwidth (8 MHz), but with the improvement can be transmitted five with similar definition quality instead of one in analogue transmission. DTV uses terrestrial network and takes profit of the receivers, antennas that are now installed. It allows mobile reception and a low cost for companies that try to open market in this area. It provides services and applications that now are possible: 16:9 quality, Multi-language audio services and MHP (Multi Home Platform) that offers an interactive and multimedia applications.

CHAPTER 2. THE DVB-PROJECT AND STANDARDIZATION

2.1 The DVB-Project Group

The DVB Project was created to unify and to agree all the specifications for digital media, including broadcasting. It is composed by around 300 companies. Although the digital technology started to appear at the beginning of the 80's, until 1990 was impossible to bring digital television broadcasting to home due to the higher investment that was needed and made it impractical to implement. Many companies as equipment manufacturers, broadcasters, decided to unify efforts during 1991 to develop terrestrial TV. It gave as a result the formation of a group for the development of digital television in Europe.

This formation was called European Launching Group (ELG) and tried to include the maximum European media interest groups, public and private, and the consumer electronics manufacturers. All the rules that were adopted by this collective and the actions that they wanted to take to expand digital TV was established in a memorandum of understanding (MoU) and it was a document describing the agreement between parties. The MoU was signed by all ELG in 1993 indicating an intended common line of action. At this moment, the Launching Group renamed itself as the Digital Video Broadcasting Project (DVB). The development work in digital television started to gear up to reach the main objective: bring digital TV to home in whole Europe.

The objective of the DVB Project were to develop digital satellite, cable, and terrestrial broadcasting technologies and promote and standardization of these. The first step was that the system would contain a combination of image, audio or multimedia. This work resulted in ETSI standards for the physical layers, error correction and transport for each delivery medium. The DVB Project delivery platforms and open standards when they are available. From the first moment, the standards have been common for all the companies and only when there would be no choice there can be differences. [1]

2.2 DVB-Project: The emergence of the standards

The DVB Project has used to promote standards and the transport for all systems is the MPEG2 transport stream.

The standards are identified with the initials which identify the area. For example DVB-S is the specification for the first generation version of the digital satellite system and DVB-S2 for the second generation version of the DVB digital satellite system.

At the beginning of the 1990s, due to the change that was happening in Europe and market priorities, the group decided to develop satellite and cable standards before terrestrial because they could develop more rapidly than terrestrial systems.

The **DVB-S** (digital satellite broadcasting) was developed in 1993. This system was created using QPSK and it introduces channel coding and error protection, that are described at the specification. The first operator that offers these broadcast services in Europe was in 1995 by pay operator Canalplus in France.

The **DVB-C** standard(system for digital cable networks) was established in 1994. It is centred on the use of 64 QAM.

The **DVB-T** system (digital terrestrial television) was more difficult to develop because of the noise introduced by the environment and the bandwidth needed and the losses introduced by the multi-path. The system required to adapt its decoding depending of the signal. The key element is the use of OFDM. It can works in two modes:

- **2K carriers + QAM modulation:** adequate when the receiver is in movement (take into account Doppler effect)
- **8K carriers+ QAM:** this mode allow more multi-path protection.

The first DVB-T broadcasts started in Sweden and in the UK around 1998.

Also there are two systems for MMDS (Multi-channel Microwave Distribution Systems). The DVB-MC that operates at frequencies below 10 GHz, which is like DVB-C and systems that operates at radio frequencies above 10GHz known as DVB-MS (which is like DVB-MS). DVB-MT is also available.

2.3 Implementation of the standards in the countries

The development of the DVB-Project was very successful and in 1997 they started to promote its open standards globally to make digital television a reality. DVB standards became the mark for digital television around the world. Japan and United States, where another digital satellite systems are used, began to use also DVB-S. Although the DVB-T system was more slowly to use for all the countries than the digital satellite and cable, it's estimated than more than 120 million of DVB receivers are around the world.

During 2009, 10 countries had completed the process to change from analogue to digital terrestrial broadcasting adopting the standard DVB-T. The switch to digital for some countries in time-lime is the following [1]:

- **2006:** Luxembourg, Netherlands.
- **2007:** Finland, Andorra, Sweden and Switzerland.
- **2008:** Belgium (Flanders) and Germany.
- **2009:** United States*, Denmark and Norway.
- **2010:** Spain and Latvia will be completely switched off in June.
- **2011:** Japan, Canada.
- **2012:** United Kingdom.
- **2015:** China.

*In United States, when the switch-over occurred, two million households were not prepared for the transition. For this reason some analogue TV signals ceased after the original date.

- **2007:** Brazil. In major cities of the country the switched was in that year. For complete signal expansion over all the territory will be in 2014.
- **2009:** Indonesia. Around the 90% of households have digital TV. The total switch-off is planned in 2012.

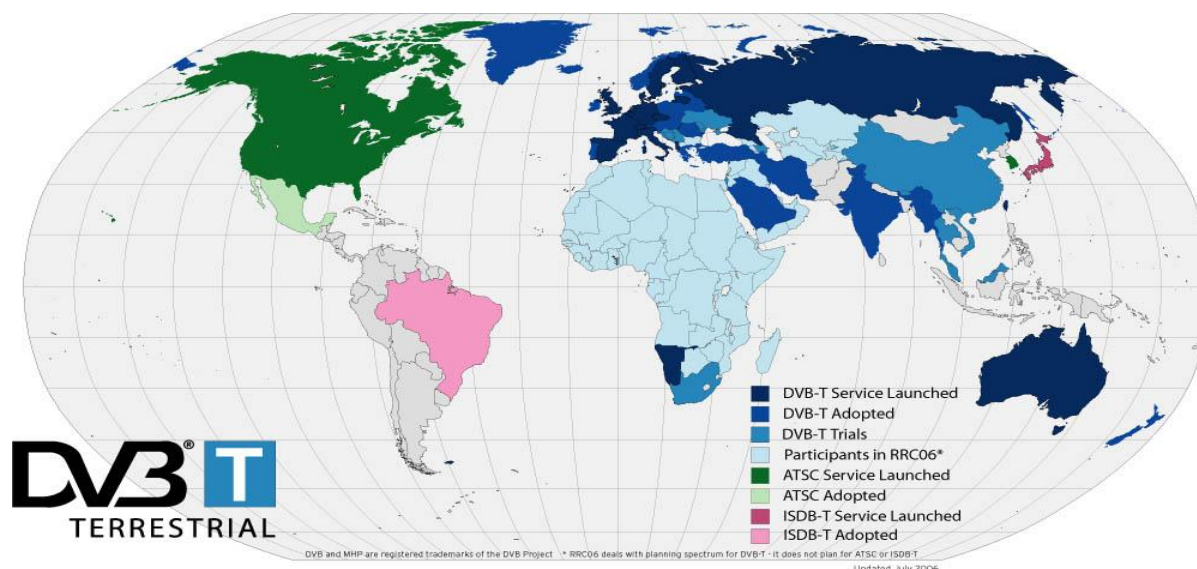

Fig 2.1 DVB-T standard adoption in the world

2.4 Recent research

Actually, another broadcasting systems are recently developed like DVB-S2. This system wants to be used for all future European digital satellite multiplexes and the receivers will be equipped with both system: DVB-S and DVB-S2.

About digital TV on mobile devices, a terrestrial system was developed: DVB-H. This one introduces a flexible and robust digital system for hand-held terminals. This system is composed by a time slicing and a 4K OFDM mode.

All the digital broadcasting systems has the capacity to deliver multimedia in addition to television programmes. The DVB Project has developed a transport system for this type of data.

2.5 European Telecommunications Standards Institute (ETSI)

The ETSI produces globally-applicable standards for Information and Communications Technologies (ICT), including fixed, mobile, radio, converged, broadcast and internet technologies.

They are a non-profit organization and recognized by the European Union as a European Standards Organization. ETSI is composed with more than 700 organizations which members are from 60 different countries across the 5 continents.

ETSI has as a main challenge to develop around the world the standards that are used for network telecommunications and another services. ETSI can be defined as a world producer, giving the telecommunications' standards for networks around the world which specifications helps to the international cooperation in this area. In Europe, this organization provides standards for the European market. This standards are regulated by the EU and they collaborate with another European organizations. It is also a services organization provider, developing standards for information and communication technologies.

All the specifications and technical information about the standards is collected in the following documents [3]:

- **ETSI Technical Specification (TS):** This document contains the technical specifications about the standard. The TS is approved by the ETSI Technical Committee proposed in the document. The DVB-Project uses this document to create the specifications of their standards.
- **Technical Report (TR):** Contains all the guidelines to develop the standards specifications. This technical report is approved by the ETSI Technical committee who proposes the document.
- **ETSI Standard (ES):** Document approved by all the components of ETSI group and not only the Technical Group that proposes it. Is more rigorous than a TR or a TS.
- **ETSI Guide (EG)**
- **European Standard (European Norm (EN)):** The most hierarchical publication approved by the European Organizations of standardization. It is included in the European and national legislation.
- **Special Report (SR)**
- **DVD Bluebooks:** Commercial documents or technical specifications that are in process of standardization.

If the studies of this organization finally don't have any valid result is included in the Miscellaneous Item. The purpose of these documents is to response to the requirements of the different industries and organizations.

CHAPTER 3. BASIC STANDARDS ON DIGITAL TV

The digital TV is transmitted by satellite, cable or terrestrial transmitters. Each one has their own standard that make possible the transmission and the reception depending of the stage. In the figure shown below is possible to see the use of this three basic systems.

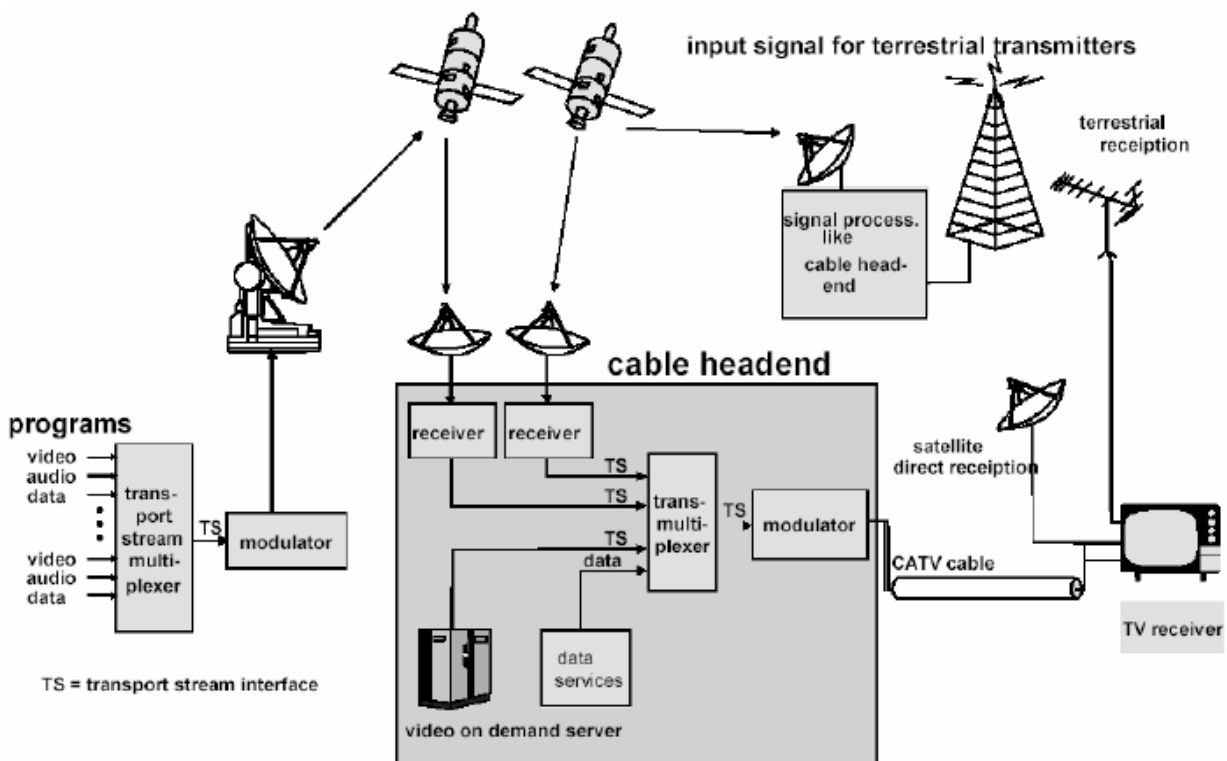

Fig 3.1 Scheme of standards DVB-T, DVB-S, DVB-C application

3.1 Digital Video Broadcasting by Satellite (DVB-S)

The system DVB-S (Digital Video Broadcasting by Satellite) allows an spectacular increase of the transmission's capacity for digital television programs by satellite using the compression video techniques based on the standard MPEG-2 for the source coding and the multiplexor. The only variation between this standard and the others proposed by the DVB (cable and terrestrial broadcast), is the type of modulation and the channel code used. For transmissions by satellite is taken the QPSK (Quadrature Phase Shift Keying) code, with a variable binary flow between 18,4 to 48,4 Mbps. [4]

Block of transmission:

The transmitter's diagram consists in the parts that are shown in the figure 3. The most important process in the transmission are the following:

- Multiplex and framework (based on the multiplexed transport of the

standard MPEG).

- Randomization of the signal.
- Advanced protection against errors (external and internal coders).
- Process of interlace.
- Digital modulation.

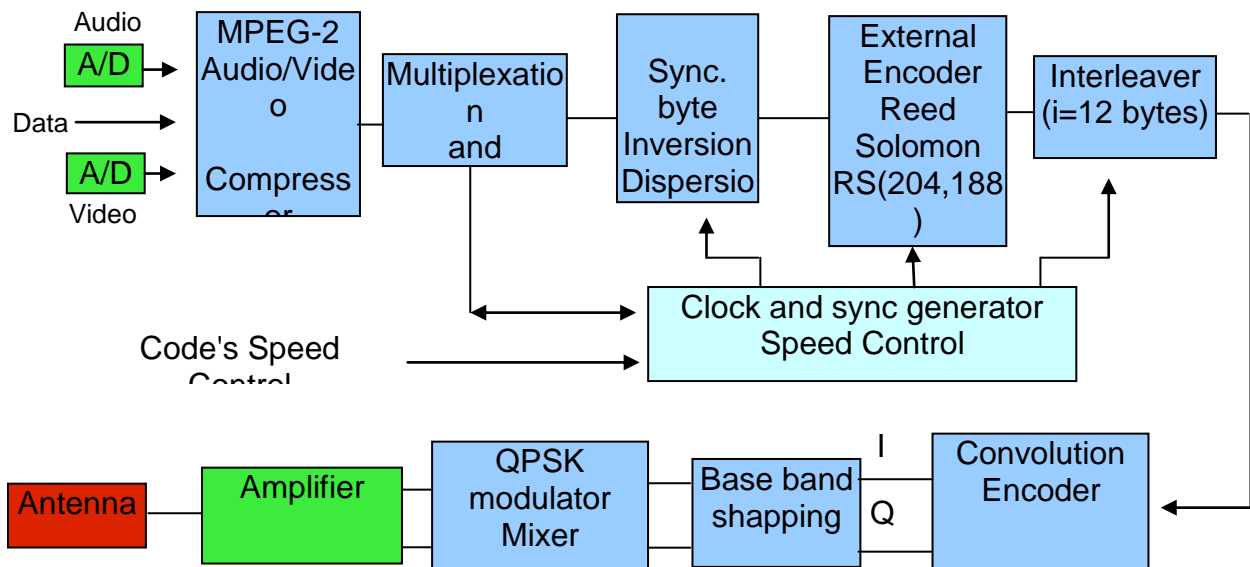

Fig.3.2 Block of DVB-S standard transmission

The inherent flexibility of the system allows an agreement among the efficiency to the spectrum (use of high speeds of transmission) and the power efficiency (low relations between carrier to noise that are required). Both characteristics are very important in the equipments that works by satellite due to the no linearity of the channel and the limitation in power of the equipments. The key element is the capacity to work efficiently in satellite channels affected by noise, interferences and distortions.

3.1.1 Source Coding and multiplex

The DVB-S system is based on the coding of the image and sound by MPEG-2. The plot's structure of the transport by MPEG (TS) consists in a packages with a fixed length, that allows to bring a great number of video services, audio and data in the same plot. The total package has a length of 188 bytes, including 1 byte of synchronism, 3 bytes of headline and 184 bytes of data. Protection against errors is not included, it will be added in a later process.

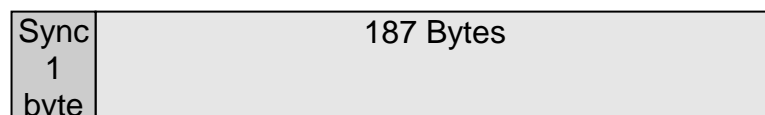

Fig 3.3 MPEG-2 transport MUX packet

3.1.2 Channel encoding and modulation

The purpose of the channel encoding and modulation is to adapt the signal in base band to the characteristics of the satellite's channel. The services DTH (Direct To Home) are particularly affected by the limitations of power, and in such a way, the protection against the noise and the interferences is necessary, as well as an efficient use of the spectrum. Due to this uses, this system requires a modulation QPSK associate to a powerful correction block of errors based on the concatenation of convolution codes and the Reed Salomon code. Once is obtained the transport block, these bits are used in a random way to facilitate the recovery of the clock signal in the receiver. Later the packages are coded with the Reed-Solomon's code RS(204,188), which adds 16 bytes of redundancy to each package, providing a capacity of correction for 8 random errors.

To increase the capacity of correction is used a convoluted interleaving based on the approach of Forney. Moreover, it is coded again with a convoluted flexible code depending on the requirements of the service.

Finally, the coded bits are changed using a code Gray in the QPSK constellation and filtrate in the base band to generate an spectrum with the form of cosine enhanced with a factor of roll-off around 0,35.

3.1.3 Block of Reception

In a basic way, the main function of the digital receiver (IRD - Integrated Receiver Decoder) is to decompress the signals of video and digital audio received in format MPEG-2 when these have been demodulated and corrected of possible errors, and to transform these in two signals of analog audio and video. These signals will already be able to be visualized in a receiver of standard television.

The signal of RF coming from the satellite, once picked up in the focus of the satellite dish, has to be amplified through an amplifier of low noise, and to be moved later to the first intermediate frequency. The band of frequencies of the RF carrier has to be, for the broadcast of digital TV by satellite, among 10.7 and 12.75 GHz (Ku-Band), while the band of the first resulting END will be among 950 and 2150 MHz. All this is carried out in an external stage called LNB (Low Noise Block).

There are two possible widths for each channel [4]:

- **FSS Band(Fixed Satellite Service):** 26 MHz and 22 Msymbols/s.
- **BSS Band (Broadcast Satellite Service):** 36 MHz and 26,67 Msymbols/s.

The tuner picks up the signal of the LNB and moves it to a second IF(intermediate frequency) of 479,5 MHz. Now the signal can already be

demodulated. In such a way, the signals that are obtained again from video, audio, and data compressed and multiplexed in the emitter can be pick up in base band for theirs back process, which consists in the inverse operations carried out in the transmitter and the correction of possible errors.

All of these techniques supplies an output data practically free of errors with a rate of error in the bit (BER) upper to 10^{-10} , and a BER around $7 \cdot 10^{-4}$ or better in presence of blast errors. The audio and compressed digital video are obtained from the demultiplexer and these are passed through the decoder MPEG-2, obtaining as a result the signals from digital video (4:2:2) and audio (PCM). The decoder also has to have additional hardware to make another type of services, like video recorder, the connection in personal computers, to the telephonic net, etc.

3.1.4 The evolution of DVB-S: DVB-S2

Another standard that is the evolution of the DVB-S is the DVB-S2 (DVB-S version 2). It includes a powerful error correction based in the use of two cascade encoders, the Low density Parity Check and the BCH code that provides a capacity near to the fixed by Shannon's limit.

In order to improve the flexibility of the system and to allow different binary speeds this system uses:

- **Different modulation's schemes:** QPSK, 8PSK, 16APSK and 32APSK.
- **Roll-off taxes:** 0.2, 0.25, 0.35.
- **Flexible inflow.**

The system is be able to change the parameters of the physical layer due channel conditions applying an Adaptive Coding and Modulation (ACM). The improvement of the capacity with the DVB-S2 over the DVB-S standard are around 30%. DVB-S2 uses the last advances in channel codification and modulation.

3.2 Digital Video Broadcasting by Cable (DVB-C)

The DVB-C system is based in the European Standard ETS 300 429 created in 1994 "Digital Broadcasting Systems for Television, Sound and Data services; Framing structure, Channel coding and Modulation for Cable systems". It is valid for any cable network defines the modulation of the packages by MPEG-2 by cable.. The characteristics of this standard are the good signal-to-noise ratio, the small space available in frequencies that can be used, the rebounds and the non-lineal distortion. This standard works with a different types of modulation: QAM, 16-QAM, 32-QAM, 64-QAM, 128-QAM or 256-QAM. The most often is 64-QAM and the FEC is exactly the same as the DVB-S.

3.2.1 Characteristics

Block scheme:

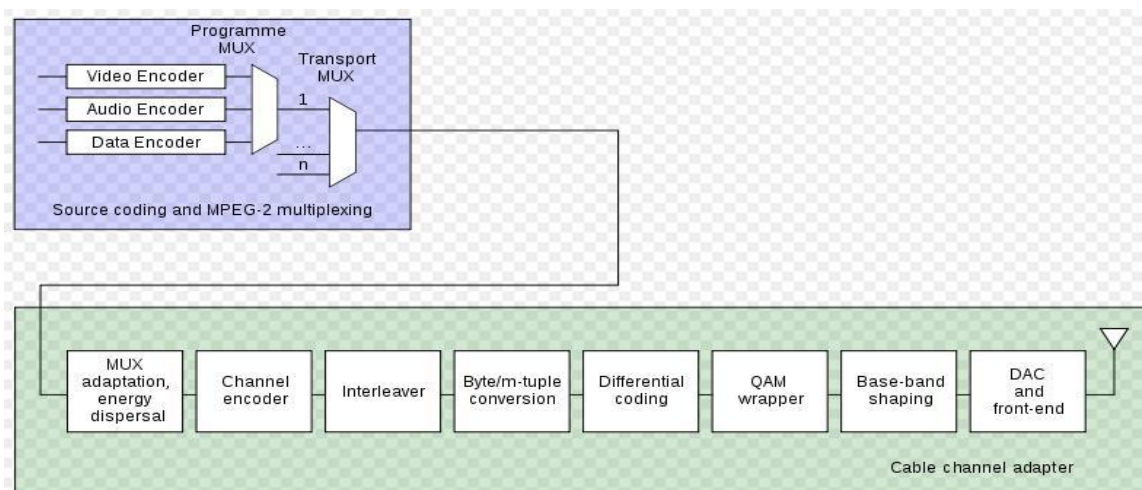

Fig 3.4 Blocks diagram of DVB-C transmission

The transmitter's block is formed by different parts:

- Random process:** At the input of the channel we have the signal on the band base, in agreement with the transport layer MPEG-2. Later, this one is submitted to a random process, in order to shape the spectrum to distribute this one uniformly. In such a way the spectrum was not centring in spectral periodic stripes, which would accentuate the interferences between symbols. The random process that is in use is the type "set-reset".
- Codification:** After the random process is applied a Reed-Solomon codification, in order to facilitate the detection of error in the receiver. The Reed-Solomon code used in the standard ETS 300 429 can detect 8 erroneous symbols.
- Interleave:** When the packages are codified, the interleave convolution is applied in order to segment and to distribute the long blasts of errors, to facilitate in a later process the detection and alteration in reception. The combination of the Reed-Solomon codification and the convoluted interleaved allow the detection of 96 erroneous symbols (768 bits).
- Conversion Byte - Symbol:** Once the signal on band base is already conditioned for the transmission, this one enters to the conversion block from byte to symbol. The number of bits that are in one symbol depends on the number of symbols in the constellation.
- Differential codification:** A differential codification is applied to the 2

bits of more weight, in order to obtain a constellation QAM invariant in rotations of $\pi/2$. Due to this differential codification, if the two more significant bits change, the points of the first quadrant of the constellation-Q AM can turn into those of the second, third or fourth quadrant.

- **Filtered:** Before the modulation QAM, and in order to reduce the interference between symbols, the signals I (in phase) and Q (quadrature) are filtered by the root of lifted cosine.
- **Modulation:** Once the signal is filtered, it is modulated in QAM and is sent, the used constellation can be 16,32,64,128 or 256 symbols.

The receiver does the reciprocal processes to obtain the sign MPEG-2 sent. [6]

3.2.2 The evolution of DVB-C: DVB-C2

The DVB-C2 standard is an adaptation between DVB-S and DVB-C. This standard is the specification that is used for Collective Antenna Systems (CATV) and TV networks by cable. It can be work inside one building or between different close buildings. The signals can be received by satellite and be combined with the terrestrial TV signals. The SMATV system represents the possibility to share the same resources for terrestrial reception or by satellite. It allows also the adaptation of the satellite signals to the characteristics of the channel.

3.3 Terrestrial Digital Video Broadcasting (DVB-T)

The digital TV system called DVB-T (Terrestrial Digital Video Broadcasting), specified in the ETSI standard (European Telecommunications Institute Standards) EN 300 744. This system is designed to allow optimum use of the available frequency spectrum with a structure of broadcast data enough to accommodate numerous services: multiplex of up to 8 video programs in a 8 MHz bandwidth (where only one analog program was broadcasting), multi-language stereo/surround channels, etc.

The architecture of the DVB-T network consists in: program coder, multiplexer, SFN network adapter, COFDM (Coded Orthogonal Frequency Division Multiplex) modulator, up converter and transmitter. It specifies all the process to use terrestrial transmission channels: channel coding and modulation.

Block scheme:

The figure 6 describes the block diagram of the DVB-T system. These blocks form the channel codification and the modulation scheme that is used by the system. The channel coding uses the Forward Error Correction (FEC) after the signal pass the transmission channel. Moreover, the modulation scheme shows the transmission type OFDM (Orthogonal Frequency Division Multiplex). The

combination of this one with the error correction and the multi-carrier modulation is the COFDM transmission type.

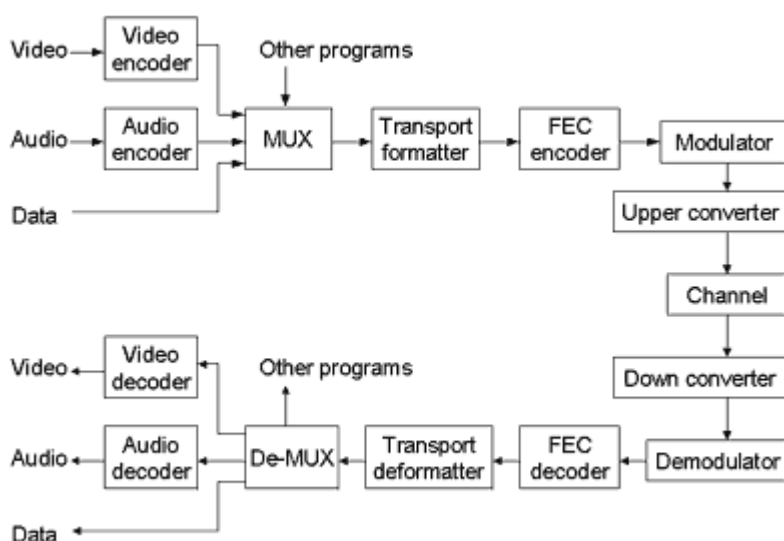

Fig 3.5 Block diagram of DVB-T standard

The DVB-T system has different configurations that will be studied below as:

- Transmission modes.
- Modulation schemes.
- Codification rates.
- Guard interval.
- Channel modulation.

All of these options can be taken with certain restrictions depending of the system that is needed.

3.3.1. Source Coding

The input signal is given by the standard MPEG-2 Transport Stream (Ts). The Transport Stream is produced by an adaptation of MPEG-2 according to ISO/IEC 13818, which multiplexes several programs and add the Information Service (IS)(ETD 300 468).

ISO/IEC 13818 was developed to give a response to the necessity to find a codification of the images in movement with the associate sound for applications like TV broadcasting, digital storage...The use of this specification means that the video can be used as bits and can be transmitted and received over the existing and future networks and distributed by the actual and future broadcasting channels.

In the ETSI EN 300 468 document is specified the IS (Information Service) that are in the streams of DVB bits. With this, the user has the services that are available and is needed for the automatic configuration of the receiver (Integrated Receiver Decoder or Set Top Box) to use the selected service. [7]

The figure 7 shows the scheme of the source coding. The compressed audio and video and the data streams are multiplexed by programs (Programme Streams), that are unified in a transport multiplex to form MPEG-2 Transport Stream. This is the stream that is transmitted and is received by the Set Top Box (STB). In this will stay a certain number of TV channels, radio and interactive services as programming schedules at the same time.

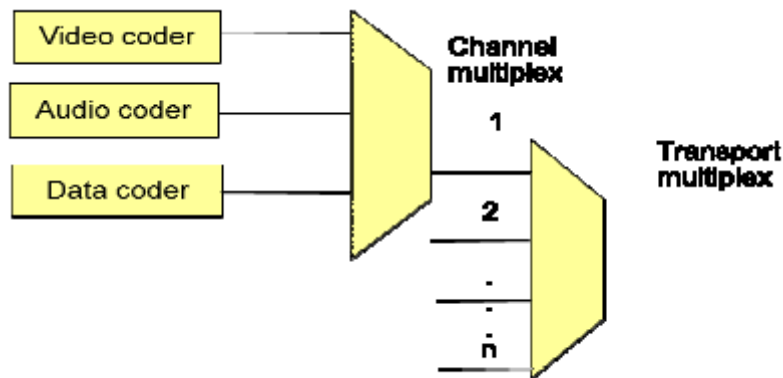

Fig 3.6 Scheme of DVB-T source coding

3.3.2 Channel Coding

The codification of the signal adds enough redundancy and protection to permit the correction of errors and to make the signal more robust. The Forward Error Correction (FEC) is used after the signal pass through the channel. This codification allows to retrieve the information transported by sub-carriers that are cancelled due to the selective fading of the radio channel.

The channel coding also describe the modulation scheme that is used in the transmission: a multi-carrier modulation OFDM (Orthogonal Frequency Division Multiplex).

DVB-T uses two types of channel coding that justify the use of letter "C" in the technique known as COFDM (Coded Orthogonal Frequency Division Multiplexing). This technique of transmission is the result to combine the codification to correct errors and the modulation multi-carrier.

There are two types of codes to encrypt the radio channel:

- **Block codes:** the information is in a code block for each block of bits with information. It also adds redundant bits. Ex: Reed-Solomon, parity...
- **Convolution Codes:** codes where the output depends not only on the

input, also depends on the previous entries. The bitrate of the output signal typically is the double, triple... of the input bitrate.

In DVB-T is used a dual-channel coding using a code block and a convolution code. In addition to the channel coding techniques are also used interleaving techniques to avoid mistakes in the exit blocks at the demodulator.

The DVB-T system allows a range of options that make it a flexible system:

- **2 Transmission modes:** 2k (1705 carriers), 8k (6817 carriers)
- **3 Modulation schemes:** QPSK, 16-QAM, 64-QAM
- **5 Relations internal coding error protection:** 1/2, 2/3, 3/4, 5/6, 7/8.
- **4 Lengths for the guard interval:** 1/4, 1/8, 1/16, 1/32.
- **Non-hierarchical or hierarchical channel modulation** with different values of alpha parameter.

The OFDM technique allows to work in small and big areas with Single Frequency Networks (SFN). This means that this system can radiate the same in reception when different programs from different operators transmitters at the same frequency. Under these conditions we obtain the maximum efficiency of the spectrum, which becomes particularly relevant when it is used in the UHF bands allocated for TV.

The DVB-T standard defines a physical layer and data link layer of a distribution system. The terminals are working with the physical layer through a Synchronise Parallel Interface (SPI) and a Synchronous Serial Interface (SSI) or an Asynchronous Serial Interface (ASI). All the data is transmitted by a MPEG-2 transport stream with a restrictions giving by (DVB-MPEG).

This system follows the OSI (Open Systems Interconnected) model. The physical layer is in the first level of OSI model. In this level is defined all the electrical, mechanical characteristics for network communication. Its presence is needed in every communication and model. The physical level make possible the bit's transformation to the sequence to transmit it from one place to another. This layer is the most basic and it only gives the medium for the transmission bits, one by one, linking network nodes.

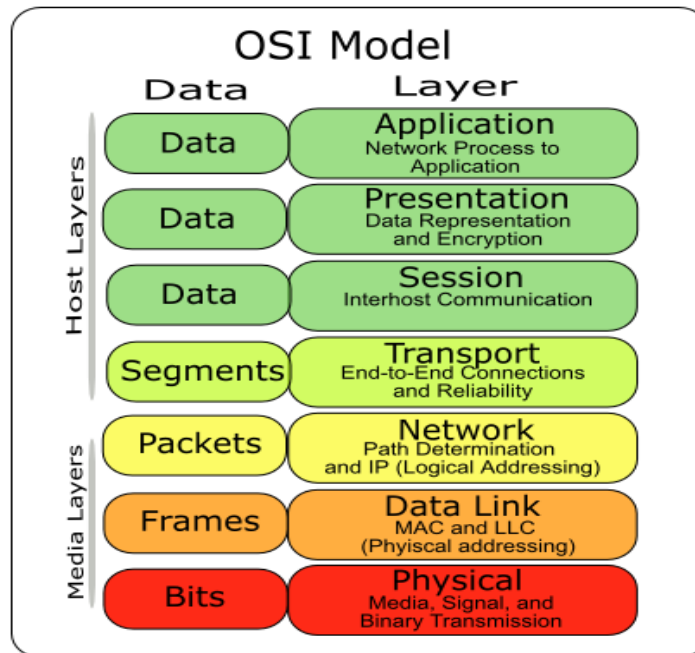

Fig 3.7 OSI model

The link layer is the responsible of a reliable transfer of the information through data transmitter circuit. This layer is the second level of OSI model and receives the request of the network level and uses the services of the physical layer. The main objective is to transfer the information, without errors between two machines that are directly connected (oriented to connexion). [9]

3.3.3 OFDM technique

To reduce the effects owing to the radio channel is used the Orthogonal Frequency Division Multiplexing (OFDM). This technique consists in a multi-carrier modulation where the signal is divided in N-flows of low speed that modules several sub-carriers.

The duration of the low speed symbols are selected in a way that exceed the dispersion time including the last echo. Every sub-carrier that is modulated has a zero in its spectrum at the frequency of the following sub-carrier. In such a way, they are orthogonal. To obtain this, the frequencies of every sub-carrier has to be separated the same value as the inverse of the low speed symbols' duration. If it chooses a large number of OFDM sub-carriers, the symbol's time of each modulated signal is higher than the echo delay and each one will be affected by flat fading. This fact, with the orthogonality of the carriers, allows the individual demodulation with quality. The echo problem is reduced and it turns into an interference between symbols (ISI), that is limited. On the other way, if the number of OFDM sub-carriers are limited, the echo delay are higher and the signal is affected by selective fading and is difficult to demodulate due to the high interferences that are in, even the signal has a great level of amplitude.

Each sub-carrier is modulated by the data output of the serial-parallel converter. In the DVB-T standard are defined three possible modulations:

- **QPSK**: 2 bits per symbol.

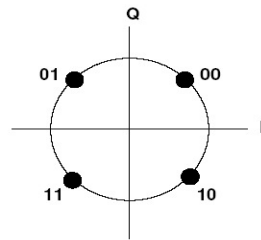

- **16 QAM**: 4 bits per symbol.

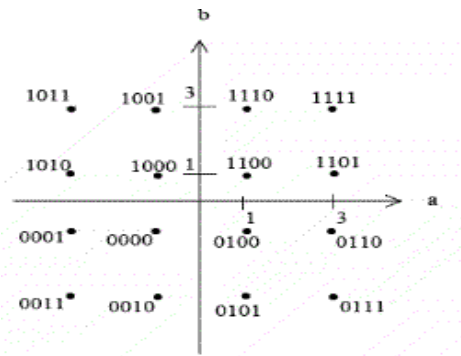

- **64 QAM**: 8 bits per symbol.

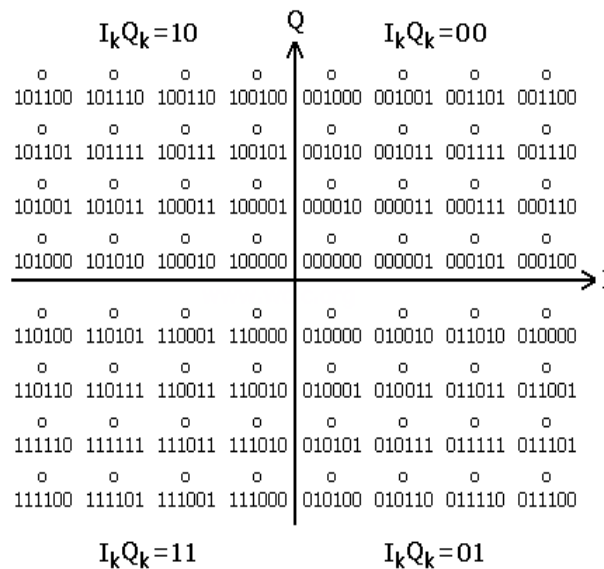

The DVB-T system also allows two possible values to the number of sub-carriers:

- **2K mode**: 1705 sub-carriers separate 4,464 kHz. 2048 theoretical carriers.
- **8k mode**: 6817 sub-carriers separate 1,116kHz. 8192 theoretical carriers.

In Finland, the DTT system uses the 8k mode. Every sub-carrier can transport until 1116 Ks/s and its capacity is around 1/4 of the capacity of one sub-carrier in the 2k mode. The number of useful carriers in DTT 2K is 1512 and 6048 in 8k mode. The rest of the carriers are used for synchronization and signalization. So, the gross symbol-rate is 6048×1116 Ms/s. The maximum value for the DTT system depends of the modulation used in the sub-carriers of 6048 in TDT 8K mode. In a 8k OFDM system exists 8192 carriers. The symbol frequency is $f_s = 9.14$ MHz, being the period $T_s = N/f_s = 8192/9.14 = 896$ us. In this time all the demodulation operations have to be done. The calculation of the FFT need around $N \log_2 N = 106496$ operations so it means that the system has to do 120 Millions of operations per second. Is this the reason that this system took a long time to appear due the needed of powerful processor.

3.3.4 COFDM

The Coded Orthogonal Frequency Division Multiplexing (COFDM) technique consists in divide the bit stream in a large number of carriers, and DQPSK modulation (Digital Audio Broadcasting, so do not need channel estimation) or QAM (DVB will require equalization) implemented in each of them.

The COFDM symbol is defined as the state of the carriers for a given symbol interval. This means that the same carrier is part of different symbols according to the instant of time that is observed. The DAB (Digital Audio Broadcasting) OFDM symbol duration is between 156 and 1246 us. These values are given by the estimated coherence time of the channel: the period of time when the channel transfer function can be considered a constant on time. Is usually greater than the OFDM symbol duration. The receiver measures only some carriers of total set of OFDM carriers and use them as a reference, which are only to measure the temporal variance of the channel.

The DVB OFDM symbol duration is between 131 and 1120 us. Similarly, if the carrier separation is sufficiently reduced, the spectral coherence (the "wrinkled" that may be the channel transfer function) can be measured properly. Usually the carrier separation is around 13 to 53kHz.

The COFDM modulation requires very precise base oscillators. If these fail, the consequence is that the scaling on the base frequency do that the receiver doesn't take large number of carriers. If a high speed is needed, the system requires a high synchronization and more precise to avoid burst of errors or loss of watches. [12]

3.3.5 Single Frequency Network (SFN)

The concept Single Frequency Network (SFN) is a network that consists in a several transmitters that are working at the same frequency. Due to the COFDM modulation that is used in DVB-T system, is needed a careful synchronization of transmitters, and a non destructive interference between signals received form different transmitters. All the receivers have the same clock status as all due to

the synchronization by GPS. This one is reached by introducing the timing information at head-end of the network and by providing an automatic alignment system is each transmitter.

The SFN is used in several European countries and introduces several benefits as improved coverage and better use of the available spectrum. [9] [14] [17]

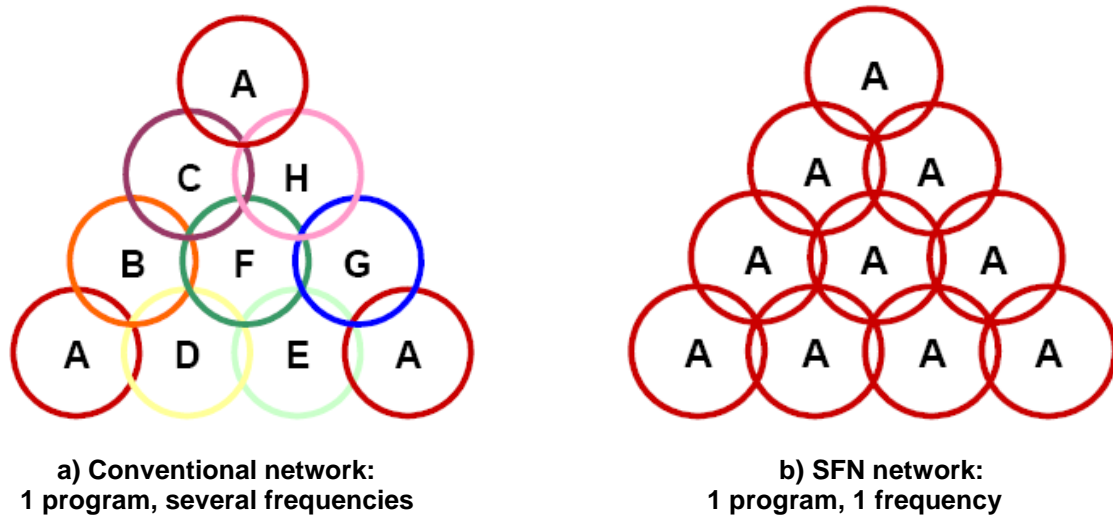

Fig. 3.8 Radiowaves planning

3.3.6 Guard interval

To minimize inter-symbol interference problems (ISI) caused by the echoes are introduced an additional guard interval at the beginning of each OFDM symbol. This means that each symbol is transmitted during a period longer than its useful. At the reception, the period to recover the signal, will start a time later when there will be a change of symbol in the main received signal (due to the interval guard). The period will be extended during the time that the signal is useful. The ISI occurs during this guard interval and out of the useful time in reception and for this reason the signal is protected against natural echoes (distant rebounds) and artificial echoes due to the transmission of the same signal from two distant transmitters as in Single Frequency Network (SFN) happen.

The addition of the guard interval reduces the transmission capacity depending on its length. In the DVB-T there are several options range on the length of the Fourier Transform (FFT) chosen. The Table 3 shows the normalized values for DVB-T.

Proportion of the useful interval taken	Length of the interval guard	
	FFT 2k mode	FFT 8k mode
1/4	224 us	56 us
1/8	112 us	28 us
1/16	56 us	14 us
1/32	28 us	7 us

Table 3.1 Length of the interval guard

One of the lengths that is possible to use for the guard band is $L_g = N / 4 = 2048$. The guard interval is $T_g = L_g / f_s = 224 \mu s$. The distance between carriers is $D_f = 1.17 \text{ kHz}$. The number of effective carriers (that are really used) is $N_e = 6875$ being the effective bandwidth around 7.57 MHz. This one is lower than the 8 MHz used in UHF channel. The symbol speed rate is $V_s = N_e / (T + T_g) = 6.06 \text{ Mbauds}$. If each carrier is modulated in 64-QAM is possible to reach a binary rate of 36 Mbps and in theory is possible to introduce around 4 or 5 channels with a good image quality. In practice, is around 3-4 channels with a quality similar to PAL (SDTV if is defined with the DVB-T standard).

The choice of the parameter T_g will be conditioned by the type of network that you want to implement. It can be the multi-frequency network (MFN) that uses different frequencies in each transmitter, to provide the same programs. Can be complemented by SFN in a local area around the MFN transmitter. The other is the single frequency networks (SFN) that uses the same frequency in all transmitters.

These can be a large area or regional level, with great separation between transmitter, a local area complementing the MFN or Gap-fillers that complements the coverage and are working in SFN.

The MFN does not affect the choice of the interval guard because it is working with different frequencies. With the smallest value of interval guard is sufficient to cancel the natural multipath. In the SFN is important, it has to provide protection against the interference of its own network. If a receiver receives two signals, the interference is constructive if the delay does not exceed the guard interval. If that delay exceeds this interval, there will be interference between symbols of destructive nature. The transition zone, where the interference is between constructive and destructive, is considered as destructive is exceed too much the interval guard. When it comes to internal interference SFN network, the interference is also destructive. The constructive interference is not properly a interference, because it can serves to improve the coverage.

In a SFN network, the guard interval has to exceed the time that the signal takes to cover the distance between transmitters. For example in the 8K mode if:

- **$T_g = 28 \mu s$ (1/32) Distance < 8,4Km. $T_s = 924 \mu s$ $R_s = 1082 \text{ symb/s}$.**
- **$T_g = 56 \mu s$ (1/16) Distance < 16,8Km. $T_s = 952 \mu s$ $R_s = 1050 \text{ symb/s}$**
- **$T_g = 112 \mu s$ (1/8) Distance < 33,6Km. $T_s = 1064 \mu s$ $R_s = 940 \text{ symb/s}$.**

- **$T_g = 224 \mu\text{s}$ (1/4) Distance < 67,2Km. $T_s = 1120 \mu\text{s}$ $R_s = 892 \text{ symb/s}$.**

The most advantageous rate to use is 1/4 in large networks. If in the system the transmitters are more separate it is possible to use a small number of these to cover the territory. On the opposite, in a very small area networks it is better to use the minimum. It will provide the necessary protection, and allows a greater binary capacity due the choice of the interval guard affects the transmission's capacity. The symbol time is the addition of the useful time, which depends only of the guard interval and the mode of transmission. The symbol rate is the inverse symbol of this period.

Therefore, there is a significant difference between the maximum and minimum, in the order of 20% of the capacity. This difference is derived only from the choice of the interval guard and is preferable to use the minimum value that provides the sufficient protection for the interference of the own system.

In conclusion, to give greater coverage, the interval guard must be longer, but to give more capacity this interval must be smaller. This is a commitment that will always take care in the planning. [9]

3.3.7 Hierarchical and non-hierarchical modulation

There are two types of modulation, modulation non-hierarchical and modulation hierarchical. In non-hierarchical modulation, all the bits that are multiple of transport TS-MPEG-2, are processed in the same way. It can transmit multiple programs simultaneously, but all with the same characteristics of robustness for radio channel. At the reception, with the decreasing of the SNR, the demodulation signal goes from acceptable to an abrupt loss of service (Cliff effect).

For this reason, there is another technique called hierarchical modulation and consists in having two ways for the information. One way with a robust encryption and modulation (and lower bit rate) and the other one with a high bit rate but less robustness. Hierarchical Modulation avoids the Cliff Effect and allows a gradual degradation of the demodulated signal. The data transmitted is divided in two streams (splitter) and each one is processed in a different way. The flow with HP (high priority) will have a low bit-rate and high protection against errors, and the flow with LP (low priority) will have high bit-rate and a low error protection. The high-priority data may be received in positions far from the transmitter where the signal to noise ratio is lower, while the low priority data are for the closest areas to the transmitter, where the signal to noise ratio is higher.

To achieve this effect the formation of the constellation map should be done in a special way. HP flow defines the quadrant of the constellation (QPSK modulation) and LP flow defines the location of each point in the constellation in the quadrant (16QAM or 64QAM).

HP flow is affected only by errors that involve a change of quadrant, which are only a small part of the total errors. This effect can be emphasized by using

non-uniform modulation where the symbols are separated from the axes. The DVB-T standard specifies three hierarchical modulation by a parameter " α " that defines the relation between the distance of two neighbouring points in the same quadrant. The value of " α " can be 1 (uniform modulation), 2 or 4. The non-uniform modulation gives more protection to the HP flow but produces a detriment to the reception of the second flow owing to the fact that for a constant power received, inside the quadrant the symbols are closer.

In hierarchical modulation there are two possibilities of emission:

- **Simulcast:** one program is divided in one version with a high bit rate and robustness and the other version with the opposite characteristics. In such a way, this program is emitted by the two flows (HP and LP).
- **Multicast:** two different programs with different robustness.

The receiver will choose the LP or HP adequate. The receiver doesn't have two different ways for each flow but it has to be able to read each channel. In bad conditions the receiver can choose a degradation of the quality, but keeping the service.

It should be clear that the uniform hierarchical modulation ($\alpha = 1$) transmits two data streams with different priority and is not equivalent to a non-hierarchical modulation where there is only one data stream.

3.3.8 Reception

The reception determines also the configuration of the values that are studied before. The type of reception is very important to fix the useful values. Reception can be fixed, portable, indoor or outdoor portable even mobile (this last one will be study in the next chapter). 8K mode, in principle does not support full mobility for example in a car. As noted before, due that the OFDM signal is sensitive to multipath, is added channel coding, block coding and convolution. The code block has fixed rate 204/188, while the convolution code rate can be chosen between 1/2, 2/3, 3/4, 5/6 and 7/8.

The selection criterion are the following:

- **Fixed:** In reception, the channel is Rice type, with a dominant direct signal and a moderate multipath distortion, so is right to take 2/3 or 3/4.
- In **portable and mobile reception** is better 1/2 or 2/3, because the channel has a stronger multipath distortion, typically characterized by a Rayleigh distribution.

It is important to take into account that the binary transmission capacity is directly proportional to the convolution code rate chosen. A lower rate means lower binary transmission capacity.

The last parameter to set is the type of modulation of the sub-carriers: QPSK, 16QAM or 64QAM.

Depending on the type of modulation chosen, noted before, the resulting binary capacity varies in wide range, being three times for the 64QAM than for QPSK, with the same coding rate. Taking into account the variety of the convolution codes that can be used, the relation between the minimum and the maximum is nearly six times. However, not all combinations are good, the modulations efficient in spectrum need more protection, it means a lower convolution code rate owing to the signal is more sensitive to interferences.

In general, should be a priority the binary capacity that is using 64QAM, even if it means less extensive coverage than QPSK or 16QAM. Although, there can be circumstances where it is preferable to use a 16QAM modulation with a higher rate encoding instead of 64QAM with a lower rate.

3.3.9 Evolution of DVB-T: DVB-T2

The DVB-T2 is the second generation of the DVB-T standard. It was published at the end of 2008. This system offers an improvement in efficiency in the use of the spectrum around 30-50% than the DVB-T.

The characteristics of this system are the following:

- ✓ The priority is to be multicast on HDTV, SDTV, and to allow the interactive and other services in digital systems and mobile devices.
- ✓ DVB-T2 will work with the antenna systems existing, in transmission and reception.
- ✓ DVB-T2 will provide a higher transmission speed.
- ✓ The DVB-T2 specification should offer improved robustness against interference from other transmitters, compared to DVB-T, potentially improving frequency reuse.
- ✓ The DVB-T2 specification shall offer a choice of various robustness and protection levels to be applied equally on all data of a transport stream carried by a DVB-T2 signal in a particular channel.
- ✓ The use of this system in SFN will allow a greater distance between the existing repeaters than in the DVB-T system.

CHAPTER 4. DIGITAL TV ON MOBILE DEVICES

One of the challenges for the mobile communications industries is to provide low-cost mass media, making them profitable for operators and accessible and affordable for users. One of the most important services is the Digital TV on mobile phones, which is expected to be the key in future mobile networks and it could open up a new market. Now cellular networks are restricted and can not support many services due to the high battery consumption that it requires the strong investment in network infrastructure needed to provide acceptable levels of coverage.

In mobile terminals, TV programs can be delivered using cellular or dedicated broadcast networks. There are many systems and standards for video broadcast networks: T-DMB, ISDB-T, MediaFLO and DVB-H. [8]

- **DVB-H:** Digital Video Broadcasting Hand-held. Is adopted by ETSI as a European Standard of Terrestrial Digital TV (TDT) for mobile services.
- **T-DMB:** Terrestrial Digital Multimedia Broadcasting.
- **S-DMB:** Satellite Digital Multimedia Broadcasting.
- **Isdb-t:** Integrated digital services, developed by Japan as the TDT standard. It allows modes for digital broadcasting TV in mobile devices. The government has assigned 1/13 part of the network for mobile and portable broadcasting.
- **MediaFLO:** New technology developed by the Qualcomm Company in America. It is based in the OFDM codification.

Only DVB-H and MediaFLO try to minimize the energy consumption, the main problem in portable terminals. DVB-H is an open international standard and in this Thesis will focus in it.

4.1 Mobile Digital TV Standard: DVB-H

The digital broadcasting standard DVB-H (Digital Video Broadcasting-Hand-held) enables the reception of terrestrial TV in portable terminals fed with batteries. This technology is an extension of DVB-T (Digital Video Broadcasting-Terrestrial) and takes the specific properties of typical hand-held terminals into account. This standard was promoted by Nokia and Motorola as an standard for the EU, and the countries that takes part of Europe will give support this format into the TV services for mobile terminals.

This standard allows to give services that requires a high data rates and offer an innumerable possibilities for content providers and network operators.

When the DVB-H was created by the DVB Project in 2002, they define the basic needs for the users of this system:

- a) To offer service for portable and mobile phones like audio and video streaming with a acceptable quality. The data rate for this purpose has to be up to 10 Mbps per channel.
- b) Mostly of the transmission channels will be in the UHF band. It can uses

- VHF band as a alternative.
- c) DVB-H needs to be powerful for geographic coverage comparable to the mobile radio environment.
 - d) This system has to take into account a several restrictions due to the capacity of the receiver terminals. These terminals have a small dimensions and battery restrictions. For this reason low power consumption is necessary to operate with hand-held terminals to increase the viewing time on mobile devices.
 - e) This system has to give services everywhere, indoor and outdoor locations. The handover between cells has to be imperceptibly in long distances and also in a vehicle at high speed. This situation is hard to control by the fact that the antennas into the hand held terminals have limited dimensions and it can introduce errors into the receiving signal. The GSM mobile radio signals are transmitted and received by the same device and as a result interferences can appear.
 - f) The DVB-H needs to be similar to the DVB-T in order to use the same transmission equipment.

The DVB-H system is specified in the following documents edited by the DVB-Project: [3] [7]

- **EN 302 304:** The central specification for the DVB-H system. It was published as the European norm for DVB-H.
- **EN 300 744:** The physical layer specification for DVB-T that has been published as a new version that includes the DVB-H physical layer.
- **EN 301 192:** Defines Time Slicing and MPE-FEC that also defines the Multi-Protocol Encapsulation.
- **EN 300 468:** This specification contains the Information Service (IS) of the system for hand-held terminals.

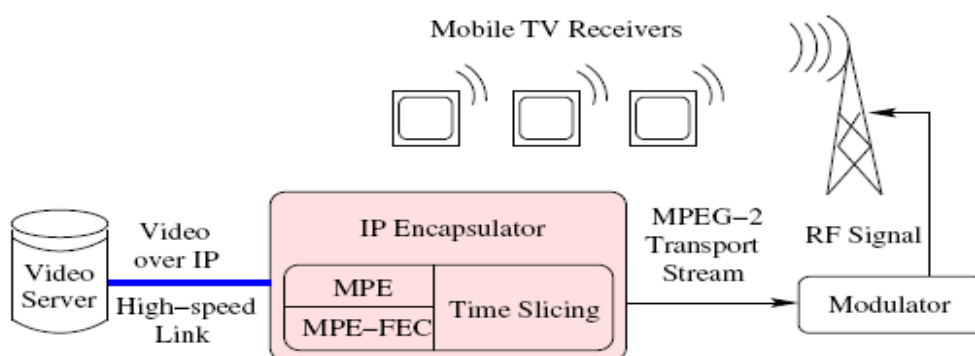

Fig 4.1 Diagram of DVB-H transmission

This system introduces three new techniques to answer the needs mentioned before: time slicing, MPE-FEC (Multi-Protocol Encapsulation-Forward Error Correction) and the 4k mode.

4.1.1 Time-Slicing

Mobile devices have a limited battery capacity and they cannot accommodate TC chips inside that consumes too much energy. DVB-H specifies that consumptions over 100 mW are impossible in hand-held terminals, and the commercial chips consume between 200mW to 500mW or higher depends on the TV chip that is used and the purpose of it. The terminal, because of the demodulating and decoding of high data-rate, also involves a power dissipation in the tuner and the demodulator part. For this reason is used the technique called time slicing.

The time slicing is a power-saving algorithm based on the transmission of different services based on time-multiplexed. In such a way, the data is not transmitted continuously but in periodical bursts with interruptions between these ones. The signal can be received selected by time. The terminal synchronizes with the bursts of the services that the user wants, and it turns to a power save mode during the time that another services are being transmitted. This is a direct measure to save power in the batteries of the hand held receivers. The bursts that enter in the receiver have to be buffered and read at the service data-rate. Time slicing requires a sufficiently high number of multiplexed services and a certain minimum burst. The amount of data that contains each bursts has to be sufficient to do the power-save period. Depending on the ratio of on-time / power-save time, the resulting power saving may be more than 90 %.

The figure 10 shows a cut-out of a data stream containing time-sliced services. One quarter of the assumed total capacity of the DVB-T channel of 13.27 Mbit/s is assigned to DVB-H services whereas the remaining capacity is shared between ordinary DVB-T services. This example shows that it is feasible to transmit both DVB-T and DVB-H within the same network. [9]

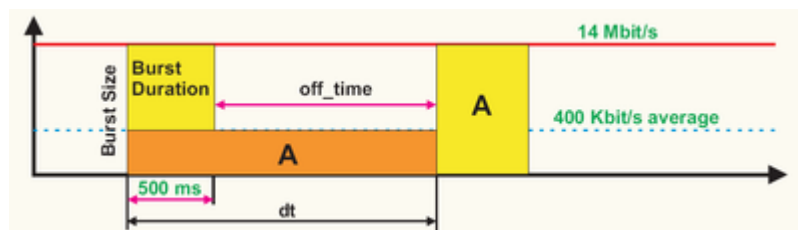

Fig 4.2 Cut-out of data stream

Time slicing introduces another benefit for hand-hand terminals. The power-save periods may be used to search channels with the service, selected by the user, in neighbouring radio cells. In this way, the terminal can works at the border between two cells ad can offer the service which remains imperceptible for the user. So, this technique allows a soft handover when the mobile phone is moving from one cell to another one.

4.1.2 Multi Protocol Encapsulation, Forward Error Correction (MPE-FEC)

The objective of the MPE-FEC is to increase the signal to noise ratio in the presence of Doppler effect in mobile channels. In such a way, is introduced a new additional error control level in the MPE layer. The redundancy information is calculated from the IP datagram and it is sent in a specific MPE-FEC sections. The MPE-FEC allows different configurations depending on the code rate that is selected. There are rates from 1/1, where there is no redundancy information, to $\frac{1}{2}$ where for each bit of information that is sent is added 1 bit of redundancy. Another that are typically used are 2/3, 5/6, 7/8, etc.

The MPE-FEC error protection is calculated and added separately for each single elementary stream before they are encapsulated into the transport stream. Using this protocol is possible to select the best rate to providing highly robust system. The redundancy that are introduced for this protocol can be compensated taking a modulation code rate lower to obtain, in the global system, a better feedback global system than if is used a DVB-T system without MPE-FEC with the same code rate.

These techniques allows a highly velocity during the reception using modulations like 8k/16-QAM or 8k/64-QAM. MPE-FEC provides a powerful immunity to impulsive noise. The receptors that are not working with MPE-FEC, but can decoder MPE, are capable to receive the data without any problem.

The MPE-FEC guarantee the reception in conditions that we are working with a poor signal, and a error-protection is introduced. The last new technique, the 4k mode for OFDM, that is next to the 2k and the 8k mode of the DVB-T standard, cover the needs of hand-held terminals. This mode acquires an agreement between transmission cell size and the capacity of the terminal.

4.1.3 4K Mode and interleave

The objective of the 4K mode is to improve the flexibility of planning network giving a better balance between mobility and the extension of the cell. To obtain more robustness of the DVB-T in 2K mode and 8K in a mobile environment and in receptions with impulse noise, is introduced a interweave technology. This mode, the 4K, is an intermediate mode between the 2K and 8K. With this, is possible to obtain an additional flexibility.

The main characteristics of the different modes are the following:

- ✓ **The DVB-T 8K mode** can be used for networks with a single transmitter small cells, medium and large. Provides Doppler tolerance allowing high speed reception.
- ✓ **The DVB-T 4K mode** can be used for networks with a single transmitter small and medium-sized cells. Provides Doppler tolerance allowing very high speed reception.
- ✓ **The DVB-T 2K mode** is suitable for networks with a single transmitter

cell small with a limited distance between transmitters. Provides Doppler tolerance allowing extremely high reception speed.

A new symbol interleaver with 4096 OFDM carrier frequencies was specified to make transmissions with the 4K mode possible. In connection with the three network modes a new symbol- interleaving scheme is defined. A DVB-H terminal should support all three modes and then needs an 8K symbol interleaver. It is preferred to use the relatively big memory of the 8K symbol interleaver in all three network modes. This symbol interleaver is able to process the amount of one complete 8K OFDM symbol or alternatively two 4K OFDM symbols or four 2K OFDM symbols. This way the memory is used more effectively and it results in an increased interleaving depth in the 2K and 4K modes, which can be expected to improve performance. If the full memory interleaving solution is used it is called in-depth interleaving.

4K mode and interweave systems affect the physical layer, although their implementations do not imply a large increase in the complexity of the circuits (logic gates and memory) on the DVB-T transmitters and receivers. A typical mobile receiver already incorporates enough RAM and logic for the management of 8K signals that already exceed the requirements for the 4K mode operation. The spectrum of the 4K mode is similar to the 2K and 8K modes and for this reason is not expected that changes are necessary in the transmission filters. [9]

Table 4.1 Requirements for each mode

OFDM parameter	MODE		
	2K	4K	8K
Overall carriers (=FFT size)	2048	4096	8192
Modulated carriers	1705	3409	6817
Useful carriers	1512	3024	6048
OFDM symbol duration (μ s)	224	448	896
Guard interval duration (μ s)	7, 14, 28, 56	14, 28, 56, 112	28, 56, 112, 224
Carrier spacing (kHz)	4.464 kHz	2.232 kHz	1.116 kHz
Maximum distance of transmitters (km)	17	33	67

4.1.4 Transmission Parameter Signalling (TPS)

The information about the modulation and coding scheme has to be known by the receiver. To inform about this, is used the TPS that specifies which feature are used. They are transmitted in parallel, 17TPS carriers for the 2K mode, 34 carriers for 4K and 68 carriers for 8K mode. The TPS is defined over 68 OFDM symbols, referred to as one OFDM frame. Each TPS block contains 68 bits. Each bit represents one characteristic of the data that is being transmitted. Every TPS carrier is differential binary phase shift keying (DBPSK) modulated. All the contents of each bit are represented in the table in the figure.

The first bit of the TPS is initialising the DBPSK. The bits 1 to 16 of the TPS form a synchronization word. Together four OFDM frames forms one OFDM super-frame. Frame numbers 1 and 3 have the same synchronization word, 0011010111101110, and frames 2 and 4 have following synchronization word, 1100101000010001. S17 to S22 is used as a length indicator to signal number of used bits of the TPS. The next section of the TPS numbers the four frames inside the super-frame from one to four, bit S25 and S26 determine the modulation scheme. S27 to S29 indicates if the transmission is hierarchical and if in-depth interleaver is used or not. The code rate for HP stream respectively LP stream is decided from s30 to S35. The guard interval, transmission mode (2k, 4k or 8k), cell identifier are signalled by the following twelve bits. DVB-H services are indicated by S48 and S49, the following three bits are reserved for future use and shall be set to zero. S48 shows if time slicing method is used or not and s49 indicates if at least one elementary uses MPE-FEC. The last 14 bits contents the parity bits for error protection.

Table 4.2 Signal bits

Bit number	Purpose/Content
S0	Initialization
S1 to S16	Synchronization word
S17 to S22	Length indicator
S23, S24	Frame number
S25, S26	Constellation
S27 to S29	Hierarchy information
S30 to S32	Code rate, HP stream
S33 to S35	Code rate, LP stream
S36, S37	Guard interval
S38, S39	Transmission mode
S40 to S47	Cell identifier
S48 to S53	DVB-H features
S54 to S67	Error protection

As mentioned before, the system has to work in indoor and outdoor locations, and can be used in various transmission bands and channel bandwidths. This system is based on DVB-T and in order to have the maximal compatibility is important to describe the characteristics of DVB-H system: coverage classes, frequencies bands where it works, the most important losses to take into account as building penetration loss and vehicle entry loss.

4.1.5 Coverage Classes

The hand-held terminal has to expect the reception under different conditions (terminal is moving, no line of sight, etc.). DVB-H services will be provided in these situations and defines now types of reception to make it possible: portable and mobile reception. When the reception is under conditions of no speed or very low speed is called portable antenna reception. Mobile antenna reception is defined for receptions at medium to high speed.

Four different receiving conditions for portable and mobile reception are the defined: [9]

- **Class A:** Hand-held portable outdoor reception. This class contains outdoor reception no less than 1.5m above ground level at very low or no speed. The receiver is assumed to be portable with an attached or built-in antenna.
- **Class B:** hand-held portable indoor reception at ground floor. This class contains indoor receptions no less than 1.5 m above floor level in rooms at very low or no speed. Reception on the ground floor and windows in the external walls of the building is assumed. The receiver is assumed to be portable with an attached or built-in antenna.
- **Class C:** Integrated car antenna mobile reception. This class contains outdoor reception (no less than 1.5m above ground level) with a moving DVB-H terminal (an example is an antenna integrated in a car).
- **Class D:** hand-held mobile reception. Includes terminals that are used within a moving vehicle, reception inside cars or vehicles. Receptions in no less than 1.5m above ground level is assumed.

Coverage in small places, around 100 m², is classified in two groups that makes possible the reception. If at least the 95% of the receiving locations of the area are covered for portable reception and the 99% are covered for mobile reception we are under a **good coverage**. An **acceptable coverage** is considered if at least 70% of the locations of the area are covered for portable reception and 90% are covered for mobile reception.

4.1.6 Band Frequency of DVB-H system

DVB-H uses the broadcast bands VHF and UHF depending of the characteristics that are needed for the terminal. There are frequencies in each band that specifies different options:

- **VHF band III:** The propagation and the building penetration in this band are very good but the problem is that it uses a wavelengths $>1\text{m}$. This is difficult to integrate in a small terminal due to the large size of the antenna that is needed. Although this band is not good for hand-held terminals, can be used in receiving systems for vehicles.
- **UHF Bands IV-V:** The propagation and building penetration are acceptable to offer a good coverage. The Doppler shifts accepted by the receivers are to a speed around 250/500 km/h and the size for the antenna of the terminal is suitable.

GSM900 transmissions are located in the upper part of the V band and it can be interferences with the DVB-H reception. Moreover, bands IV and V are congested by broadcasters of analogue TV and Digital TV services. The access of these bands could be delayed until the switch-off of the analogue TV.

4.1.7 Building Penetration Loss

The DVB-H reception will take place in outdoor and indoor locations, and is very important to study this losses to make sure the transmission in a good quality. Depending on the materials and the construction of the buildings that are through the communication will attenuate significantly at indoor locations. The range of the losses can be between 7 and 15dB. The median value in the UHF band is around 11 dB.

The penetration loss is defined as following: [9]

$$Penetrationloss = 10 * \log\left(\frac{1}{N} \frac{(\sum_{i=1}^N P_{i_{outdoor}})}{(\frac{1}{M} * \sum_{j=1}^M P_{j_{indoor}})}\right) \quad (4.1)$$

The numerator defines the summation over N outdoor power measurements and in the denominator are the indoor power measurements for a fixed transmitter location.

Not this one is the only loss due the transmission for hand-held terminals. The vehicle entry loss is taken into account to measure the power of the transmission to obtain good quality. For mobile reception is very important the consequences of receptions inside cars or any others vehicles. The ETSI proposes an entry loss of 7dB in case of Class D mobile reception. The value for a car is about 8dB. The penetration loss varies from 3.2 to 23.8 dB depending on frequency, illuminated vehicle side and the antenna orientation inside the vehicle.

Vehicle penetration loss are described by a long normal distribution. At a frequency around 600 MHz the vehicle entry losses are obtained with a standard deviation of 7.9 dB.

The penetration loss into another vehicles like trains are difficult to evaluate depending of the type of train and due to the high velocities that causes large Doppler frequencies.

The influence of the people are also important. People walking around the receiver antenna varies the level of the signal, and the losses are around +2.6dB to -2.6dB. These variations are small compare to the losses that are introduced by buildings or vehicles.

4.1.8 IP (Internet Protocol) in DVB-H system

The main difference between the others DVB transmission systems is that DVB-H system is based on IP instead on the DVB Transport Stream adopted from the MPEG-2 standard. The IP encapsulate is the basic element in the DVB-H system and the IP interface allows the system to work with other IP networks. Even so, the MPEG-2 transport stream is also used by the base layer.

The IP encapsulate do the following tasks:

- Managing IP input data to be encapsulated.
- Building plots.
- Calculate the Forward Error Correction (FEC).
- Build the MPE sections and MPE-FEC.
- Build system information (SI).
- Generate packages (Transport Stream) and TS multiplexed with the SI .

The IP data is into the transport stream by the Multi-Protocol Encapsulation (MPE). Is this level is added the Forward Error Correction (FEC). This technique called MPE-FEC as we can see before complements the physical layer over the same in the DVB-T standard.

The objective of this one is to get a better signal-to-noise ratio that is needed for reception in the mobile terminals. The proofs that were made by the DVB members showed that with this technique there was a gain around 7dB over the DVB-T system.

The MPE-FEC technique located on the link layer at the level of the input streams before the encapsulation by MPE. After the use of the time slicing and the MPE-FEC the IP packets are embedding into the transport stream. To guarantee the compatibility with the DVB-T transmission network, all the data processing that is done in the DVB-H is carried out before the transport stream. The MPE-FEC scheme uses the Reed-Solomon (RS) Code with a block interleaver. In the following figure is represented the MPE-FEC structure.

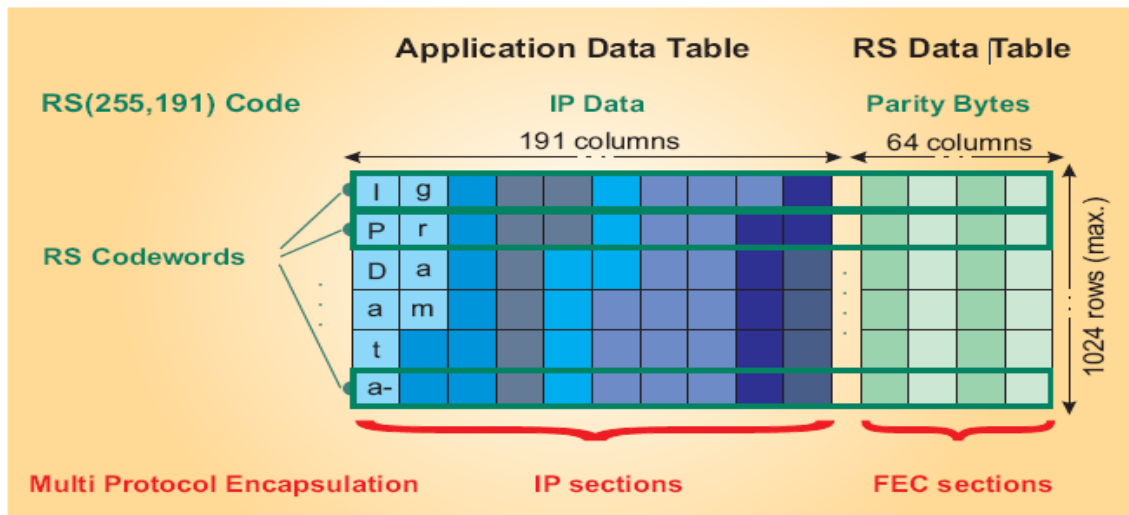

Fig. 4.3 MPE-FEC structure

The MPE-FEC creates a frame structure (FEC frame) that incorporates the incoming data of the DVB-H codec. This FEC frame consists in a maximum of 1024 rows, it can be 256,512,768 or 1024 and 255 columns. Each one of the cells corresponds to one byte and the maximum frame size is around 2Mbit.[11]

As shown in the figure there are two tables, the Application Data Table and the RS Data Table:

- **Application Data Table (ADT):** It is formed by 191 columns. It has the IP/UDP packets of service that need to be protected (the information is there).
- **RS Data Table:** It is formed by 64 columns. Contains the parity bytes of the RS code.

Through the relation between the two tables, it is possible to set different tax rates of the MPE-FEC code (discussed above). There are multiple options of configuration, which you can choose the modulation, redundancy to be used and the size of frames. In the ADT each IP packet is placed after the previous, vertically and taking into account the number of rows of the frame. At the end, is added a certain number of columns (padding) to fill in all the ADT. This Padding are introduced when there are no more IP packets of the service to encapsulate or if the MPE-FEC code needs a determinate number of columns with IP data due to the configuration selected. In the figure 13 is showed how to put the IP packets in the ADT.

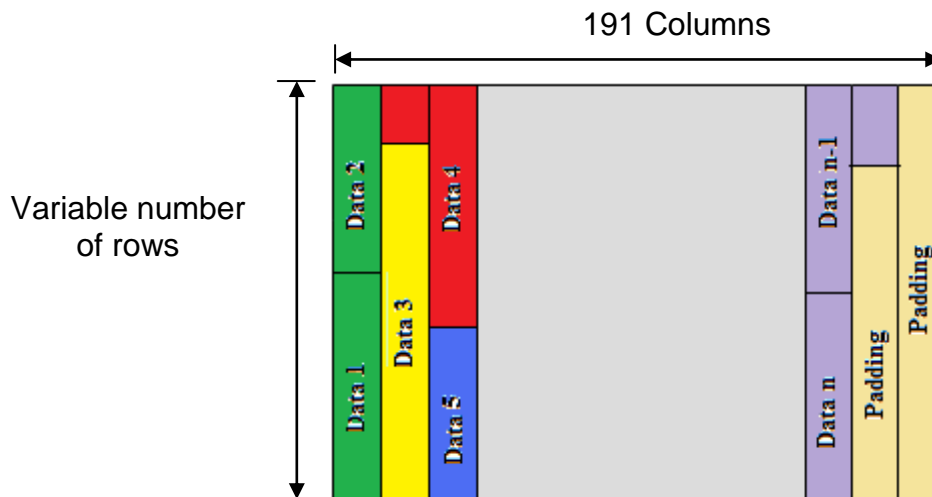

Fig 4.4 IP packets disposition in the ADT

First is needed to apply the RS (255,191) code. Once it is apply, the IP packets are read out of the application data table and are encapsulated in IP sections, the data that contains is followed by the parity data read it form the RS table and are encapsulated in FEC sections. After this process, is used the time slicing.

The IP data and the parity data of each burst are separated due to the use of MPE-FEC decoding in the receiver is optional, and if it doesn't have the decoder, the parity information is ignored.

4.1.9 Competing Standards

The DVB-H standard has some others competing standards that are used in different parts of the world.

-Satellite-Digital Mobile Broadcast:

S-MDB is a hybrid between satellite and terrestrial system. It uses a geostationary satellites and with a network of gap-fillers working with Base Transceiver Station (BTS) that provides urban indoor coverage . The synchronism in this system is very important to work with signals from the satellite with the gap-fillers. The forward error correction and interleaving is used to make the transmission.

This system is used in Korea and consists in a multi-beam configuration with six spots and three satellites. With one spot is possible to cover several countries where the capacity can be shared by different operators and it is possible to support different multimedia services on the same carrier and is possible to reach 2Mbit/s per beam. S-MDB complains the 3rd Generation Partnership Project (3GPP) standard for Mobile broadcast/Multicast Service. That makes possible to the Universal mobile Telecommunications terminals (UMTS) to support Mobile Satellite Service-band (MSS).

S-DMB can be used as a complement for terrestrial networks over unicast terrestrial 3G UMTS mobile network that makes it a multicast network.

-Mobile Broadcast/Multicast Service:

The existing GSM and UMTS cellular networks can offer a type of service that is an IP data cast. This service is the MBMS that was standardized by several groups of 3GPP. This standard will facilitate the multicast transmission into mobile networks and the integration of broadcast. It brings a high quality for mobile TV using a low bandwidth that means lower cost. This is attractive for many operators and eliminates the need to introduce new hardware into their networks.

The MBMS allows to offer voice services, data and TV over the infrastructure that already exists. It is possible to transfer video and audio clips and also real streaming. All this services can be multiplexed with the MBMS standard on the same carrier. According to the estimations the 30% of the terminal will support MBMS at the end of 2010.

The only disadvantage is the transmission of heavy streaming in a big area with a lot of users, where is better the alternative DVB-H.

CHAPTER 5. CONCLUSIONS

In the thesis is studied the digital TV and the different systems that are used to develop it. The digital TV reached this last decade the maximum expansion for almost all the European countries and some others around the world. The basic standards developed makes possible the transmission by cable (DVB-C), by satellite (DVB-S) and terrestrial (DVB-T). The DVB-T was the last developed and the most important one which opened the way to make possible the Digital TV on mobile phones.

The DTT is based in the DVB-T standard. In this thesis is studied this project that was developed by different countries around the world and was compared to another existing in another countries.

For a better understanding of the project was presented the details of the implementation of the DVB-T standard: source coding, methods of compression, network types, aspects of transmission, ... This part of the project is very important to understand the DVB-H, the standard that is used in Europe for the reception of TV in the hand-held terminals and is based in the terrestrial standard.

As is studied, DVB-H is based in DVB-T, but there is one important difference that is the new techniques that are introduced by the standard for mobile terminals. One is the time slicing, that is added to the system to decrease the power consumption of the terminals to a level that can hold the mobile devices to watch TV in live. This technique resolved the most important problem for the engineers when they were researching how to bring the TV to the terminals. Even so, this technique has some drawbacks. The first one appears when the user wants to change the channel and he has to wait a few seconds before the next burst are transmitted where the service that he wants is. For the user the result is that there will be no picture until the burst needed is received. The second problem is if there is any problem with the burst that is received, because if the receiver has bad reception the terminal will do not have any video to show until the next burst. This is a problem when in the channel transmitted there is a live football match.

As known, DVB-H can use all existing DVB-T base stations and only the base that are necessarily have to be built in the future. This is an economical advantage for the operators that can use the stations that already exists for both systems DVB-T and DVB-H. Another advantage is that this standard is a broadcasting system that means that can be used for several users that wanted the same service and for this reason they need a huge bandwidth. As a result the spectrum has to be efficient and with this standard it is possible. If is compared the DVB-H system with the 3G network the main difference is that the last one streams services to each user separately. This is useful for the operators that can control how long is the user watching TV for the payment.

Another techniques introduced over the DVB-T system are the use of the 4k mode instead of the 2k or 8k mode and the MPE-FEC. These are added to the system to make it more robust over interferences and errors and to make this system more flexible.

The DVB-H system is suitable to work with the mobile devices that already exists except for some frequencies that need a large bandwidth to cover and the antenna of the hand-held terminals are not so big to support it.

Is important to note the considerable saving of energy that is doing with the DVB-H system, which saves 90% of batteries phone and the mobility that it provides. This is very important to reduce the environmental impact. The no necessity to install new antennas is a also important for the landscape impact because this system can use the television antennas on the existing sites that were placed.

All these systems are recently developed and there may be deficiencies that change some implementations of the digital TV standards. For example the DVB-T2 that is in a development process or the introduction of the DTT by satellite. We are living in a constant changes where the technology has to be revised to adapt its to the emergence of new needs.

CHAPTER 6. BIBLIOGRAPHY

- [1] DVB – History of the DVB Project Available in: <http://www.dvb.org/>
- [2] Brice, Richard: “Guide to Digital TV”. Newnes, Second Edition, Oxford 2003.
- [3] ETSI. Available in: www.etsi.org
- [4] Reimers, Ulrich: “DVB - The Family of International Standards for Digital Video Broadcasting”. Springer-Verlag Berlin Heidelberg, 2005.
- [5] Benoit, H. : “Satellite Television: Techniques of analogue and digital television”. Arnold New York, 1999.
- [6] Morris, Steven; Smith-Chaigneau, Anthony : “Interactive TV Standards”. Focal Press Oxford. 2005
- [7] Fa-Long, Luo: “Mobile Multimedia Broadcasting Standards”. Springer-Science+Business Media, New York, 2009.
- [8] Kornfeld, Michael and Reimers, Ulrich - DVB - The emerging standard for mobile data communication, Institute for Communications Technology, Jan 2005.
- [9] ETSI EN 300 468 V1.3.1 (1998-02): “Digital Video Broadcasting (DVB); Specification for Service Information (SI) in DVB systems”.
- [10] ETSI TR 101 154 V1.4.1 (2000-07): “Digital Video Broadcasting (DVB); Implementation guidelines for the use of MPEG-2 Systems, Video and Audio in satellite, cable and terrestrial broadcasting applications”.
- [11] ETSI, TS 102 591 v1.1.1. Digital video broadcasting; IP Datacast over DVB-H: content delivery protocols implementation guidelines. October

2007.

- [12] B. Le FLOCH, M. ALARD and C.BERROU. "Coded Orthogonal Division Multiple". 1995
- [13] M. ALARD and R. LASSALLE. « Principles of modulation and channel coding for digital broadcasting for mobile receivers ». EBU Technical Review, n° 224, August 1987.
- [14] "DVB-T Single Frequency Network Architecture" Available in: www.spectracom.fr
- [15] U. Reimers (Ed.): Digital Video Broadcasting (DVB) – The International Standard for Digital Television, 2nd ed. Springer: Berlin, Heidelberg, New York, 2004. ISBN 3-540-43545-X.
- [16] DTG RF sub-group document no. 67: UHF Transmission and Reception Digital Television Group, 2003.
- [17] TS 101191 v1.4.1: Digital Video Broadcasting (DVB); DVB mega-frame for Single Frequency Network (SFN) synchronization ETSI, June 2004. Available in: www.etsi.org