

## INSULATED DOUBLE LAYER MEMBRANE FOR AUDITORIUM

N. PAULI<sup>\*†</sup>

<sup>\*</sup> Laboratoire Innovation Forme Architecture Milieux (LIFAM)  
Scholl of Architecture of Montpellier  
ENSAM, 179 rue de l'Esperou, F-34093 Montpellier Cedex 5, France  
e-mail: nicolas.pauli@montpellier.archi.fr, web page: <http://www2.montpellier.archi.fr/lifam/>

<sup>†</sup> Abaca Lightweight Structures Engineers  
5 rue Marceau, 34000 Montpellier, France  
e-mail: bet.abaca@wanadoo.fr - Web page: <http://www.abaca-engineers.com>

**Key words:** Tensile roof, Double Layer Membrane, Isolated, Ventilated, Auditorium.

**Summary.** The aim of the paper is to describe the isolated tensile roof of the auditorium in the town of Auch in the CIRCA area (France) delivered in 2012. The size of the auditorium is 41x25m h19. The total surface of the membrane is 2200sqm for each skin. The architects of the project was ADH Architects, Nicolas Novello located in Bordeaux, France. Abaca was the project and workshop drawings engineers for the membrane. Jacques Anglade located in Port Vendres (France) was the wooden structures engineer. Manufacturers of the tensile roof were VSO, Artigues près Bordeaux, France.

### 1 CONTEXT

The described project takes place in a vast program of refurbishment of a military area (Caserne d'Espagne) situated in the town of Auch in the south of France. The global purpose of the operation was the creation of the Centre for Innovation and Research for Circus (CIRC) and included the refurbishment of former stables dating from the second half of the nineteenth century as a residence and rehearsal place for circus artists. It included also the creation a big auditorium (which has to be understood as de Circus tent) with variable gauge between 400 and 1000 seats. The auditorium had to become the urban icon of the site

The purpose of this paper is to present the auditorium (fig.1), more specifically its two layered isolated en ventilated textile skin. The engineering office Anglade Structure Bois (Port Vendres) was in charge of the wooden structures. The engineering office Abaca-Nicolas Pauli (Montpellier) was in charge of the textiles envelops and theirs interfaces.

The auditorium was designed under the standards of the "Tents" NF EN 13782 [1] in order to simplify the fire security constrains. The design of the skins was under the European Guide [2] and was taking into account the local climatic loads.



Figure 1: External view of the auditorium

## 2 GENERAL CONCEPT

### 2.1 Wooden structure

The building has an elliptical ground plan of 48x32m and a height of 19m. It has a global cylindrical form with ends in a quarter of sphere (fig. 2). Its structure is composed of 22 truss arches in laminated timber.

As the building has to include spectacle equipments and to propose a versatile and adaptable space with modular grandstand, a large technical steel truss is integrated inside the wooden structures. Two levels of walkways at h6.50 et h13.50m are designed (fig. 3).

An opaque skylight is designed at the top of the building. It is covered with traditional PVC membrane water proofing upon isolated wood panel. This device allows the positioning of vertical ventilation dampers, adapted to the fire safety rules and needed ventilation of the internal space.

The vertical wall, beside 0.00 et 6.50m are realized with rigid isolated sandwich panels. They close the internal space with their contact with the h6.50m walkway. Two truck doors h4.50 and four public doors h3.00 are the exits of the building.

The security with the external areas is ensured by peripheral railings h6.50 realized with weaved steel rods.

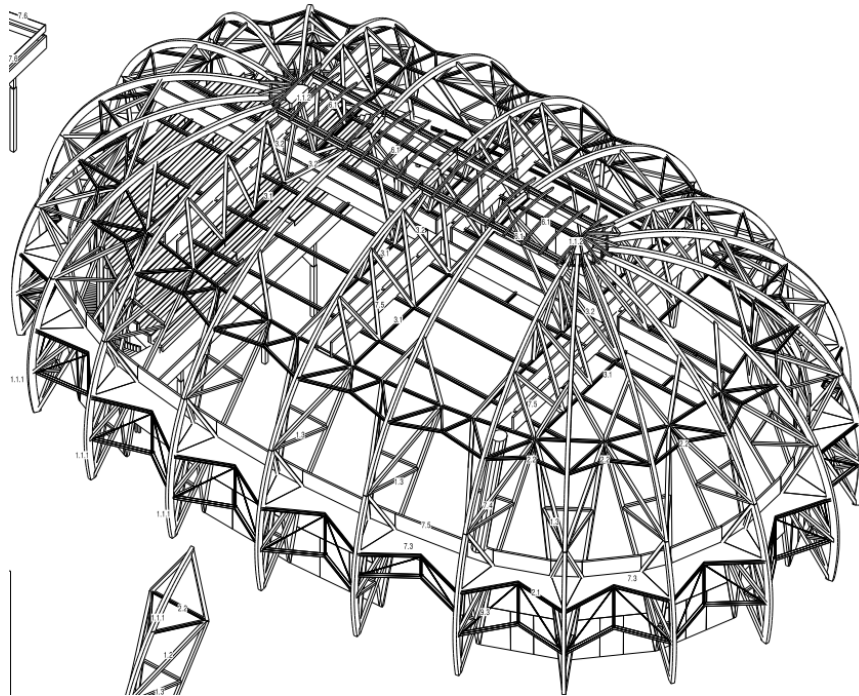

Figure 2: Aerial view of the structure (Source Anglade Structure Bois)

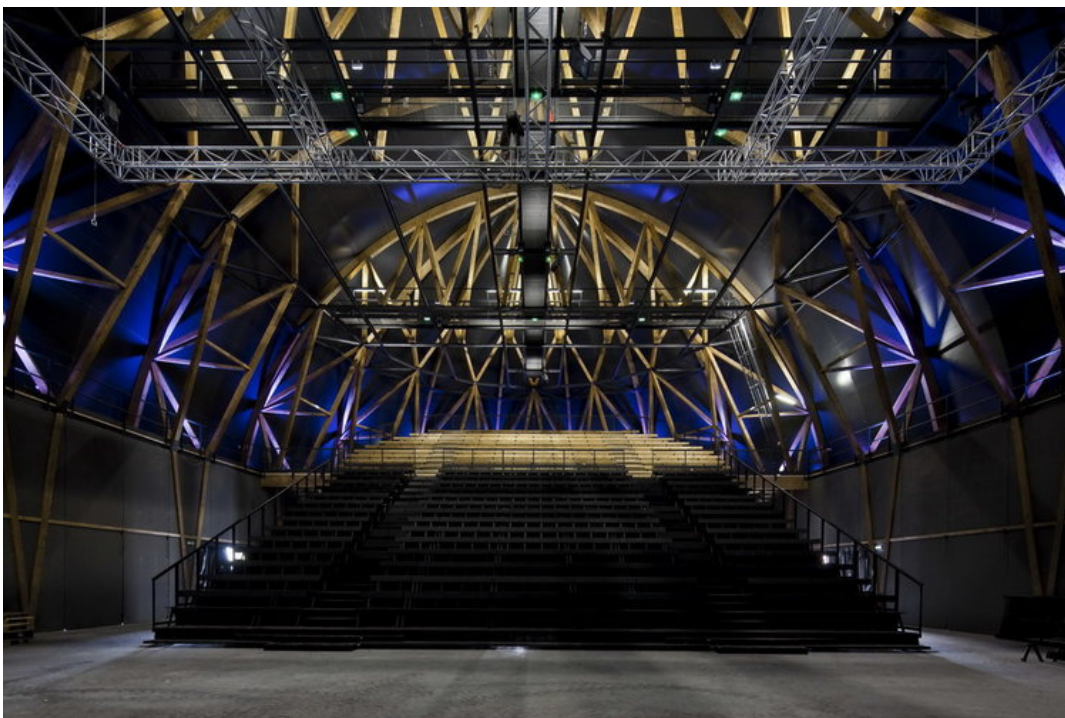

Figure 3 : Internal view of the auditorium

## 2.2 Isolated ventilated double skin concept

The envelop concept is based on the use of 2 textiles skins with a distance of 250mm. Within this empty space, a 160mm rockwool insulation layer ( $U=0.2 \text{ W/m}^2\text{K}$ ) is put in place, on the internal membrane.

The interest of the concept is to preserve the Circus Tent aesthetics (well know building of the circus artist using the place), but including thermal and acoustic comforts of traditional concert hall (fig. 1).

This approach is, by essence, opaque; which is not a drawback in this case. Nevertheless, this concept is not adapted for a building where translucency of the membrane (major intrinsic quality) is searched.

Ventilation between the two skins is a priority to avoid condensation accumulation. Thus, venting areas has been design respecting the standard 1/500 of the surface of the panels. For the lower areas, they have been positioned in the lower zone upon the internal membrane (black grid will be seen later) and the the upper areas, within the spaces of the upper lacing ropes (fig. 4). Further more, the internal insulation has to be protected from the condensation droplet. We choose to fasten, in a waterproofed manner, the rookwool layer on a textile in order to drive the condensats lower thar the insulation zone.

As the membrane have a very week permeance (they are water and vapour proofed), a ventilation of the internal space has been integrated using the ventilation dampers placed in the upper zone of the roof. They are slaved to the temperature and the hygrometric level measured inside the auditorium (fig. 4).

The used membrane are Polyester/PVC membrane from Ferrari : standard 702S opaque White/Blue for the internal skin and standard 1002S translucent white/white for the external skin. The fabric supporting the insulation is a standard white 402.

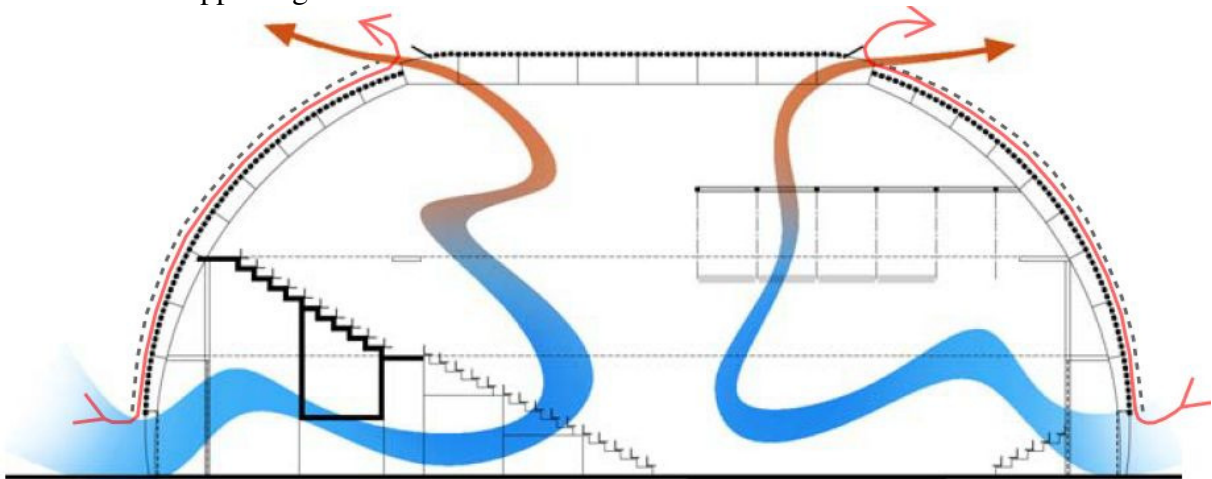

Figure 4 : Slaved ventilation for the internal space and passive ventilation for inter-membrane space  
(Source ADH Architectes)

### 2.3 FormFinding, behaviour under climatic loads and cutting patterns of the membranes

The forms of both layers of membrane (fig. 5) have been calculated using the Force Density Method [3] using our home made software under AutoCad\_ARX. Composed of 22 modules, each module form presents a ply in its middle. This choice, allows finalising easily the overall tension of the panel (with fixed peripheral anchoring) with the only use of a strap and its tensioning pawls.

We pay attention to adjust the curvatures in each point of the membrane to avoid any contact between the internal skin and the wood walkway at the 6.50m and 13.50m level. The distance has been minimized to limit the lack of comfort of the walkways. And at least, the curvatures have been checked to remains in the standard values.

Despite the symmetry sensation, the overall surface consisting à 44 modules is made from 10 different modules

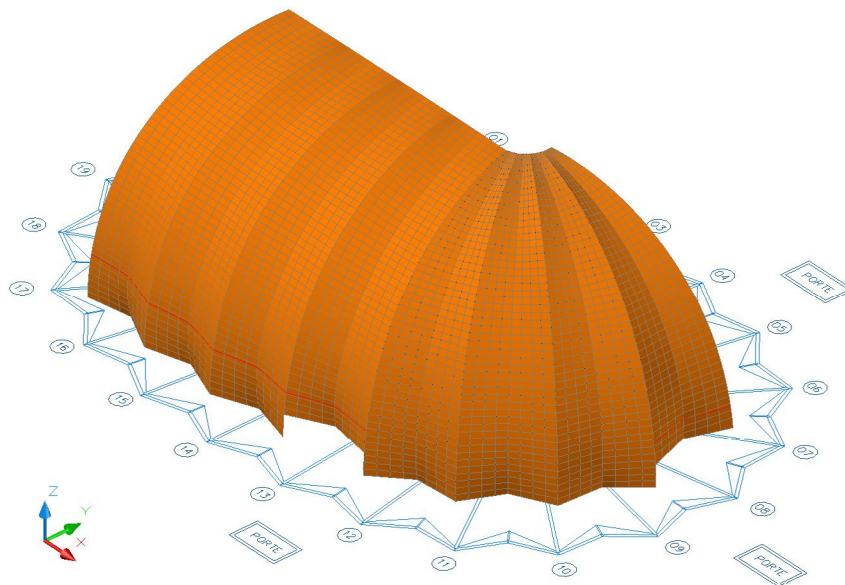

Figure 5 : Form Finding of the 2 layers of the tensile skin

The behaviour analysis under climatic loads has been realized using a cable net model under Robot Structural Analysis Software (RSA) from AutoCad. The internal skin had only prestress loads with the own weight of the insulation. The external membrane has been loaded with required climatic load extract from Eurocode 1 and its French Annexes. The anchoring loads have been gathered and given to the wood structure ; they have been also sorted for the dimensionnement of the steel connecting parts and their fastening of the wooden trusses.

The cutting patterns have been realized using our home made software under AUtoCad\_ARX. Beyond the classical 3D->2D projection, our tools allow to adopt and control the reductions and compensations to take into account to avoid wrinkles. Taking into account arches variable curvatures and various configurations of doors, 208 different panels are needed to realize the whole skins. Data's have been transferred numerically to

manufacturer for automatic cutting under Lectra Systems.

### 3 DETAILING

#### 3.1 Lacing and valley straps

The concept adopts that membranes are laced all along their peripheral edges on upper and lower tensioning beams. The lower one, which has a « V » form to increase the curvature effect, is included within the two membranes, and, thus make it invisible. The rectangular 150x100 hollow section is completed on its vertical face by two round pipes (diam 33mm) P1.4 to produc a 250mm large profile. A lacing pipe P1.2 (fig. 6) is added on the lower face for the both internal and external membranes.

The tensioning device using straps is hanged on P1.9 piece for the external membrane, and on P1.5 piece for the internal membrane.

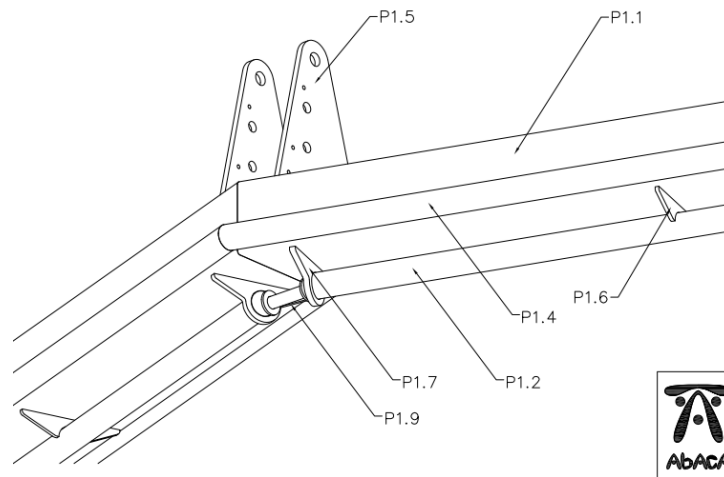

Figure 6 : Lower tensioning beams – View from the inside

Thee device is similar the the upper tensioning beam, with a lacing on pipe Q1.2 and Q1.4 and the fastening of the straps on Q1.5 and Q1.6 (fig. 7).

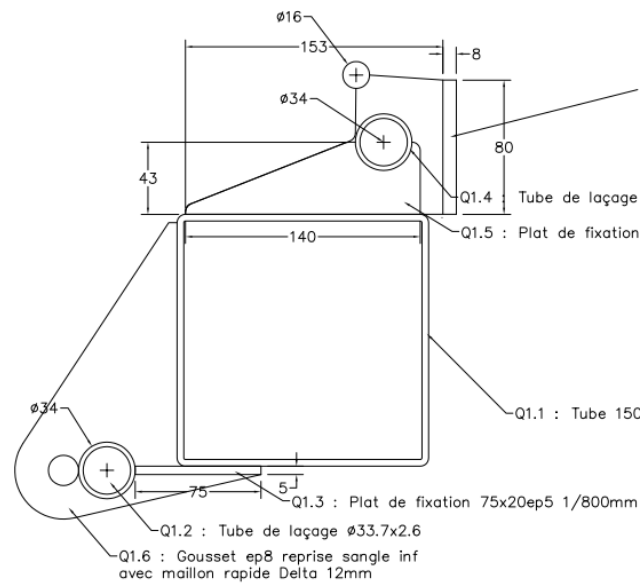

Figure 7 : Upper tensioning beam – Cross section

The valley straps are specifically protected and equipped by manufactured PES/PVC cases.

### 3.2 1 piece internal membrane and 22 pannels external membrane

The concept is based on the perfect waterproofing of the internal skin to avoid damaging the wood by moisture. Of course, internal ventilation is an associated fact. Thus, the internal membrane is realized in 1 piece of 2200sqm creating a watertight barrier between in and out.(fig. 8).



Figure 8 : View of the first layer of membrane

Lacing pipes for insulation and external membrane are then fastened after the first membrane. In one hand, specific steel pieces have been designed to fasten the upper and lower tensioning beams with a possible fitting of their positions. In other hand supporting plates have been designed to fasten current lacing pipes on the arches extrado (fig. 9).

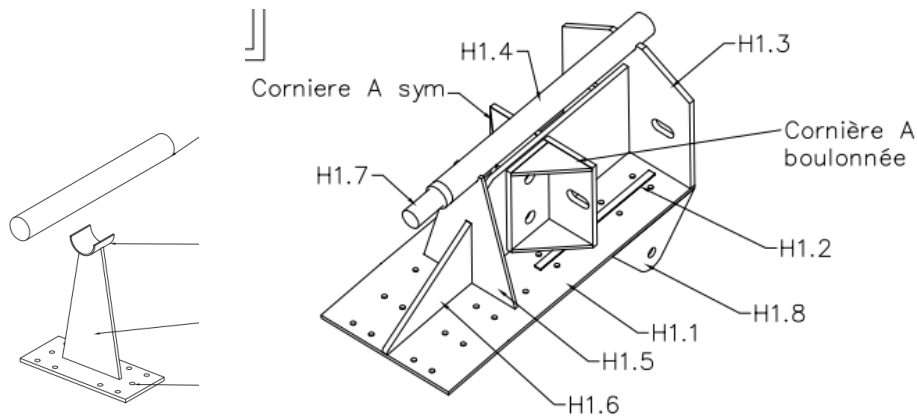

Figure 9 : Current support arches for current lacing pipe and specific piece to fasten tensioning beams

We can notice (fig. 8) the black grids made from FT381 Ferrari fabric to allows the lower ventilation. The size are precisely dimensioned to be larger than 1/500 of the surface of the module, including the permeability of the fabric.

External pannels are prepared on their edges to receive a watertight covering flap (skirt) which provide a perfect finishing architectural aspect (fig. 10).



Figure 10 : Watertight covering flap with HQ architectural aspect

### 3.3 Insulation complex

The insulation is realized with a 160mm Rockwool fastened upon a 400g/sqm PES/PVC membrane. To ensure the waterproofing of the textile support, a specific bolting system has been developed and successfully tested (fig. 11).

The supporting panels have been cut according the 3D geometry, as the internal or external membranes. Fitting devices have been added to allow regular fastening on the arches steel pipes (fig. 12).





Figure 11 : Tensile insulation support : large prototype and water tightness testing of the bolts



Figure 12 : Three layers are visible: Left inner membrane, Right isolation layer, Centre outer membrane

In order to avoid that condensation corrode the lower steel tension beam, we designed a “water collector” at the bottom of the insulation layer, such as windows aluminium frame drainage which collect temporarily the condensation and let it evaporate during the day.

### 3.4 Rain gutter

The HQ lower finishing work requires a smart rain gutter hiding efficiently lacing of the membranes. Our design has been realized carefully in order to be as compact as possible, in accordance of the areas of cross section rules, easy to dismantle for maintenance and guide aesthetically water to collecting manhole (fig. 13).

### 3.5 Isolated soft tensile doors

Doors have also been design carefully. To stay in the concept of soft envelop, the architect choice went to tensile doors which has to be isolated.

The concept is the use of an Thin Reflecting Isolation (IMR) (5mm complex composed generally of aluminium foils and non woven fabric foam). We respect strictly the prescription of the French Centre Scientifique et Technique du Batiment (CSTB) to implement this solution [4] and obtain a  $U = 0.6 \text{ W/m}^2.\text{K}$  composite :

Membrane PES/PVC + 20mm space + IMR U 1.6 + 20mm space + Membrane PES/PVC.

The chosen wedge device is 20mm thick EPDM strips on the 1/500mm frequency. A set of pulley and sliding pieces allows to handle opening without efforts (fig. 14).

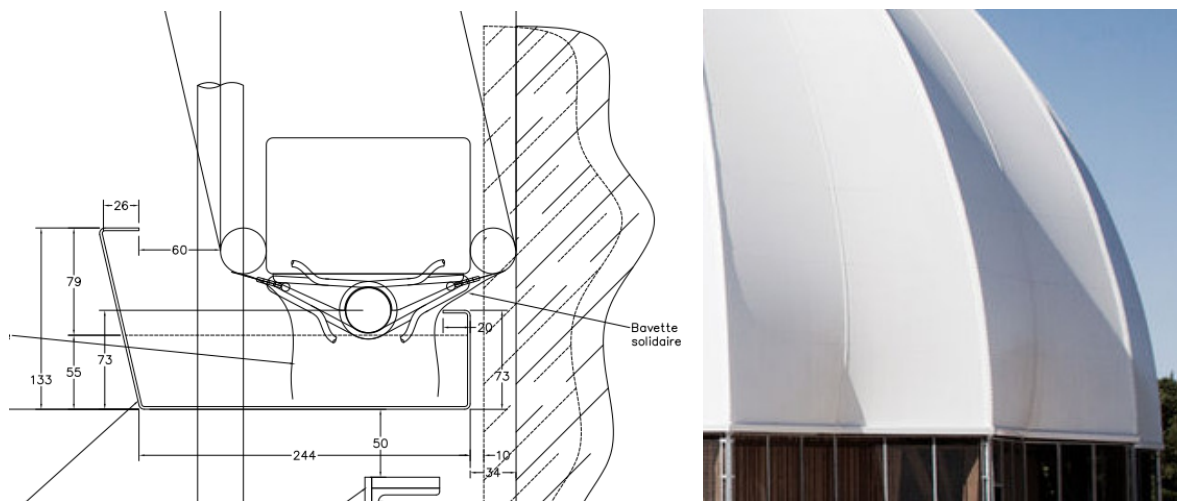

Figure 13 : Cross section on the rain gutter and HQ architectural aspect

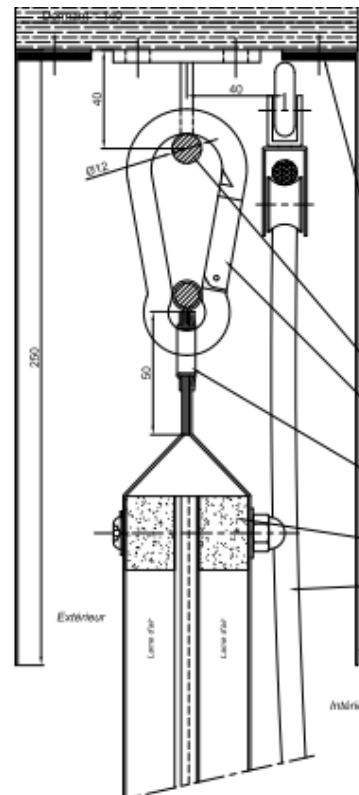

Figure 14 : Cross section of the isolated tensile doors

#### 4 CONCLUSION

This paper describes the designing details and also realisation tricks of a two layer isolated tensile envelop. Various details are presented in order to share un positive experience for such a type of envelop.

#### REFERENCES

- [1] AFNOR, “EN 13782 - Temporary structures, Tents.” Feb-2006.
- [2] B. Forster and M. Mollaert, “European design guide for tensile surface structures.” Tensinet, 2004.
- [3] H.-J. Schek, “The force density method for form finding and computation of general networks,” *Comput. Methods Appl. Mech. Eng.*, vol. 3, no. 1, pp. 115–134, Jan. 1974.
- [4] Groupe specialise G20 and Produits et Procedes, “Performances des produits réfléchissants opaques utilisés dans l’enveloppe des bâtiments en tant que complément d’isolation thermique.” CSTB, 12-Dec-2007.