

UPCommons

Portal del coneixement obert de la UPC

<http://upcommons.upc.edu/e-prints>

URL d'aquest document a UPCommons E-prints:

<http://upcommons.upc.edu/handle/2117/90923>

Article publicat / *Published paper:*

Donatus Halpaap, Meritxell Vilaseca and Cristina Masoller, "Incoherent Light Sources for Speckle Reduction in Double Pass Ocular Imaging" Optical Coherence Imaging Techniques and Imaging in Scattering Media II, Maciej Wojtkowski, Stephen A. Boppart, Wang-Yuhl Oh, Editors, Proc. SPIE 10416, 104160S (2017)

Copyright 2017 Society of Photo-Optical Instrumentation Engineers. One print or electronic copy may be made for personal use only. Systematic electronic or print reproduction and distribution, duplication of any material in this paper for a fee or for commercial purposes, or modification of the content of the paper are prohibited.

<http://10.1117/12.2286069>

Incoherent Light Sources for Speckle Reduction in Double Pass Ocular Imaging

Donatus Halpaap^{a, b}, Meritxell Vilaseca^a, and Cristina Masoller^b

^aCentre de Desenvolupament de Sensors, Instrumentació i Sistemes (CD6), Universitat Politècnica de Catalunya, Rambla de Sant Nebridi 10, 08222 Terrassa, Barcelona, Spain

^bDepartament de Física, Universitat Politècnica de Catalunya, Colom 11, 08222 Terrassa, Barcelona, Spain

ABSTRACT

The double pass imaging method is used to obtain the point spread function of a patient's eye; however it suffers from speckle formation. Here we present a comparison of speckle formation in double pass imaging using three different semiconductor-based light sources.

Keywords: double pass imaging, speckle reduction

1. INTRODUCTION

The double pass (DP) technique is based on imaging a point source onto the retina, where the light is reflected and recorded after its second pass through the ocular media.

It is a well-established method¹ to evaluate the optical quality of a patient's eye, being capable of determining its aberrations as well as intraocular scattering. From the double pass image, the modulation transfer function (MTF) of the eye can be obtained,² which is an important measure for the quality of an optical system. In the present case it describes the contrast loss in the retinal image in dependence of an object's spatial frequency (cycles per degree).

For double pass imaging, mainly lasers are used as illumination source due to their high beam directionality and sufficient power. The use of infrared illumination has the advantage of the patient's comfort, while green light provides a better estimate of the MTF³ although the pupil will be constricted - limiting the diameter in which aberrations are finally assessed. However, the combination of high coherence of a laser and the relative unevenness of the human retina lead to a speckle pattern that superimposes the actual double pass image and hinders its interpretation.

In commercial double pass systems, speckle formation is avoided by the use of a vibrating mirror in the optical path in combination with a long enough exposure time of the camera.⁴ The final image is the average over many images superimposed by different speckle patterns. The disadvantage of this method is that moving parts increase the complexity of the system and are prone to malfunction.

Accordingly, our objective is to develop an alternative solution that renders the vibrating mirror unnecessary by employing a compact, reliable and sufficiently incoherent light source. Its output power and wavelength shall be optimally tuned for maximum speckle reduction in ocular imaging, providing the best trade-off between output power and incoherence. Another trade-off may have to be made regarding bandwidth. A larger one could reduce speckle while a smaller one is desirable to not underestimate the MTF due to chromatic aberrations of the eye.

Further author information: (Send correspondence to D.H.)

D.H.: E-mail: donatus.halpaap@upc.edu

M.V.: E-mail: meritxell.vilaseca@upc.edu

C.M.: E-mail: cristina.masoller@upc.edu

Since speckle formation poses a problem in many imaging applications that utilize coherent illumination it has been investigated for a long time. Work that may be helpful for our objective may be based on optical feedback into a laser diode to obtain multimode operation that varies over time.⁵

As a starting point, in this work we compare speckle formation in DP imaging for three light sources: a laser diode, a light-emitting diode (LED) and a superluminescent LED.

2. EXPERIMENTAL SETUP AND PROCEDURE

The experimental setup is schematically depicted in Fig. 1. By using beam splitters BS1 and BS2 (both 50/50), three light sources S1 – S3 can be compared without the need of realignment after changing a light source. For the patient’s comfort, light sources with emission in the near-infrared are used for imaging. The collimated beam from the light source being used is guided to the eye by the hot mirror hM, a Badal system consisting of two lenses and two movable mirrors M1 and M2 for correcting the spherical aberration of the eye under test and finally a dichroic mirror dM.

The entrance pupil EnP has a fixed diameter of 2.0 mm. The setup also comprises an artificial and variable exit pupil, ExP, controlled by a diaphragm wheel that is located in the plane conjugated to the patient’s natural pupil plane. In this study, optical quality measurements were performed using a standard exit pupil diameter of 4.0 mm.

The eye camera EC is used to check the eye position relative to the light beam. In order to see the eye through the dichroic mirror dM with a cutoff at 900 nm, the eye is additionally illuminated with 940 nm LEDs during positioning.

After its second pass through the eye and the system in reverse direction, light is coupled out by beam splitter BS3 (50/50) and recorded by the CMOS camera DPC (model IDS UI-1240SE-M, $5.3 \mu\text{m} \times 5.3 \mu\text{m}$ pixel size).

A fixation target, FT, is used to help patients fixate view to infinity during measurements in order to avoid accommodation changes as much as possible. The fixation target can be seen through the hot mirror, which only reflects wavelengths in the infrared, as it is the case for the light used for the DP measurement.

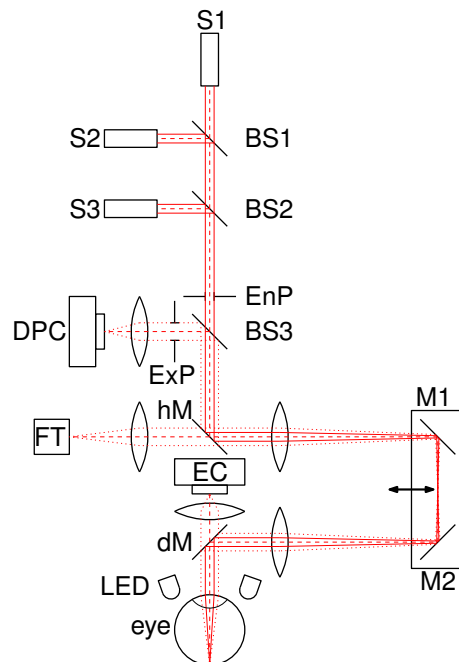

Figure 1. Scheme of experimental setup. S1 - S3: light sources, BS1 - BS3: 50/50 beam splitters, EnP/ExP: entrance/exit pupil, hM: hot mirror (with possibility to vibrate), dM: dichroic mirror, FT: fixation target, DPC: double pass camera, EC: eye camera, LED: illumination of eye.

3. RESULTS

After building the system described above, we did double pass measurements of an eye model that mimics the properties of a real eye with collimated light in the near infrared from three different light sources: a 780 nm laser diode (by Monocrom), an LED ($\lambda = 780$ nm, bandwidth $\Delta\lambda_{\text{FWHM}} = 28$ nm, by Thorlabs) and a superluminescent LED ($\lambda = 800$ nm, $\Delta\lambda_{\text{FWHM}} = 34$ nm, by Superlum). All measurements were performed with the same exposure time of 500 ms for comparability and to use the whole intensity range of the camera even with the least powerful of the sources, the LED. The two-dimensional point spread functions obtained for each light source are shown in Fig. 2. In Fig. 2(d – f) show speckle formation is suppressed by vibration of the hot mirror, while the vibration is turned off in Fig. 2(a – c). Speckle is especially visible when the laser without mechanical speckle reduction is used.

The images obtained suggest that speckle formation decreases although not as much as using the vibrating mirror.

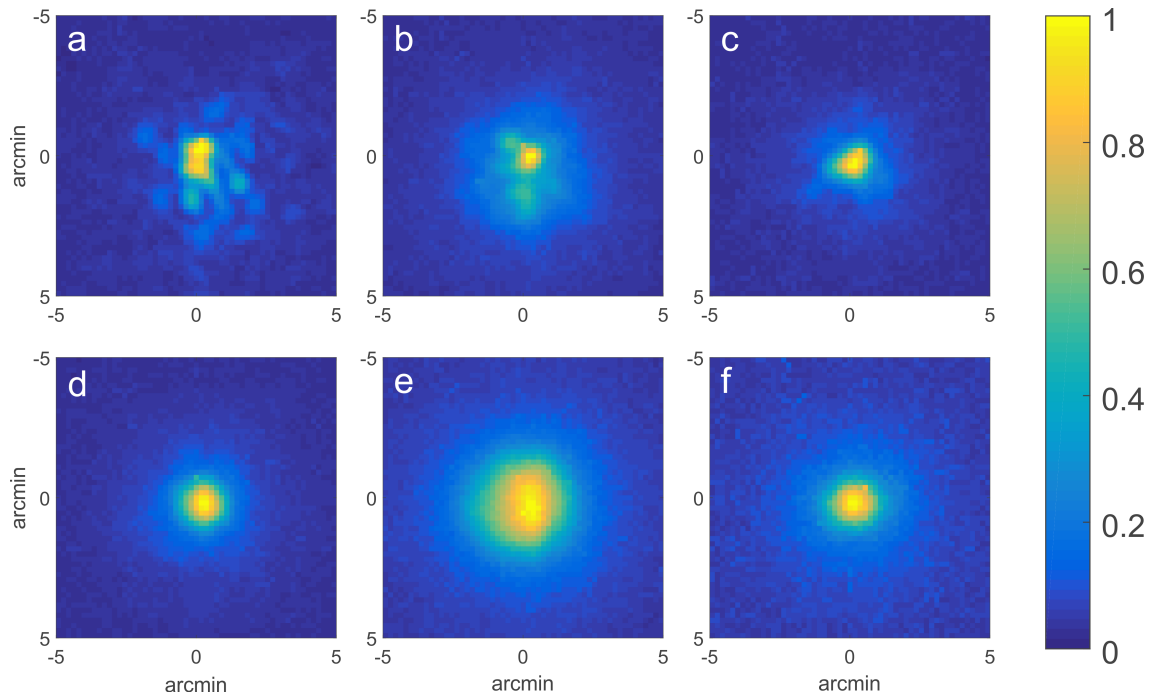

Figure 2. Two-dimensional point spread functions. The color represents the intensity measured by each pixel of the DP camera, normalized by the maximum value. (a, d) Laser, (b, e) LED, (c, f) SLED. Upper row: Vibration turned off, speckle patterns superimpose the images. The influence of speckle strongly depends on the source. Lower row: Speckle suppression by a vibrating hot mirror.

The quantification of speckle in DP imaging is subject of our current work.

4. CONCLUSION AND FUTURE WORK

With the setup described above we were able to record and compare double pass images taken with a laser, an LED or a SLED as light source and with and without a vibrating mirror in the beam path. We conclude that using a spectrally broader source with less temporal coherence indeed leads to less speckle in the DP images as expected. However, speckle is not suppressed to the same amount as when using a vibrating mirror in the beam path. The LED is relatively inexpensive, but has the disadvantages of difficult collimation and low intensity. Ongoing work is devoted to develop an efficient measure to quantify the degree of speckle reduction in the obtained images.

5. ACKNOWLEDGMENTS

This work was supported by the European Union through the project Advanced BioMedical OPTICAL Imaging and Data Analysis (BE-OPTICAL) under Grant 675512.

REFERENCES

- [1] J.L. Güell, J. Pujol, M.Arjona, F. Diaz-Douton, P. Artal, “Optical Quality Analysis System: Instrument for objective clinical evaluation of ocular optical quality,” *J Cataract Refract Surg* **30** 1598–1599 (2004).
- [2] P. Artal, I. Iglesias, N. López-Gil, “Double-pass measurements of the retinal-image quality with unequal entrance and exit pupil sizes and the reversibility of the eye’s optical system,” *J. Opt. Soc. Am. A* **12** 2358–2366 (1995).
- [3] D. R. Williams, D. H. Brainard, M. J. McMahon, R.Navarro, “Double-pass and interferometric measures of the optical quality of the eye,” *J. Opt. Soc. Am. A* **11** 3123–3135 (1994).
- [4] Optical quality analysis system (OQAS) by Visiometrics SL, Terrassa, Spain. Website: www.visiometrics.com
- [5] B. Dingel, S. Kawata, “Speckle-free image in a laser-diode microscope by using the optical feedback effect,” *Opt. Lett.* **18** 549–551 (1993).