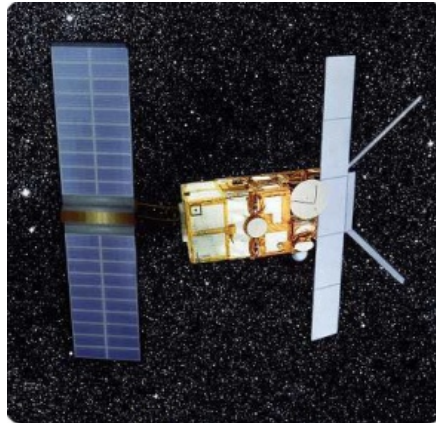

Image formation for Synthetic Aperture Radar using MATLAB



Supervisor: Zhishun She
Author: Mireia Cequiel Mir

ABSTRACT

The study of SAR (Synthetic Aperture Radar) image formation using MATLAB it is explained in the following project. The main to use MATLAB in this project was the most important thing to choose it. As MATLAB it is one of the most tools used by engineers, I considered really interesting the project, and moreover with the image treatment that it involved.

The study of this field requires some background information to identify the steps which must be done to obtain some results. SAR images treatment it is quite complex so, we must study all the background that the image formation involves, and learn in MATLAB the main functions which will have to be used.

According to this project, the main fields which were considered to study once one realizes what it involves are:

- an overview of satellite,
- what Doppler frequency involves,
- information about the radar we are going to obtain the images,
- the main programs which can be used to acquire and treat SAR images,
- some information about the file and its characteristics to understand the information it contains,
- study about MATLAB, and its main functions to obtain images
- study about the overall process in MATLAB which must be done
- results obtained

When all the steps will be followed, the conclusions will be also a part of the project due it summarizes the results and the knowledge acquired during all the realization of the report.

ACKNOWLEDGEMENTS

I would like to thanks Zhishun She because thanks to him I have been able to find out all the information about all that type of Radars. He has been the one who has introduced me to that interesting world of the treatment of image radars and helping me to find out some information. I also would like to thanks David Sandwell and his mate Meng Wei from the Institute of Geophysics and Planetary Physics (University of California, San Diego) to guide me along the difficult moments during the elaboration of this project.

CONTENTS PAGE

CHAPTER 1

1.1.- Executive Summary	1
1.2.- Terms of references	3

CHAPTER 2. Findings and analysis

2.1 Radar	4
2.1.1. Brief History	4
2.1.2. Basic Concepts	5
2.1.3 Doppler Effect	7
2.2 Types of Radars	8
2.2.1 RAR	8
2.2.2 SAR	9
2.2.2.1 Range Resolution	11
2.2.2.2 Azimuth Resolution	11
2.2.2.3 SAR applications	13
2.2.3 InSAR	15
2.3 Satellites History	16
2.3.1 ERS-1/2	16
2.3.2 ERS-2	17

CHAPTER 3. Experimental Part

3.1 Digital SAR Processor	19
3.2 Software's	24
3.2.1 Software's to treat the images	24
3.2.2 MATLAB as the best software	26
3.2.2.1 Main Functions	27
3.2.2.2 Data Obtained	28
3.2.2.3 Code in MATLAB	30

CHAPTER 4

4.1.-Conclusions	34
4.2.- Recommendations	36

References	36
Appendix	37

CHAPTER 1.

1.1.- EXECUTIVE SUMMARY

The main aim of this project will be to analyse the code in MATLAB to extract images from the data downloaded of a SAR (Synthetic Aperture Radar) satellite (ERS-2). These satellites by sending a chirp to the earth and acquiring the reflection of the ground surface, obtain some data. This data must be treated correctly though to acquire the images of the surface we want to define. To obtain the final image there are some basic steps to follow to do it properly. Moreover there will be some steps which will be done on board in the satellite; these would be the demodulation and the digitization of the data. Once the information is sent, the main purpose will be done by the Digital SAR processor. To process these data which would be the RAW signal data file with its own parameters, the range compression will be done, the patch processing, the range migration of the data, and finally the azimuth compression to get the expected SLC (Single Look Complex) image data file. Once we can get it, the images in MATLAB would have to be seen easily. Straight on the steps to acquire the signal and obtain de SLC image:

- Demodulate. By sending a chirp to the surface we want to analyse we obtain the data. These will give us the information we need, once in the satellite knowing that it has a bandwidth of 15MHz, we have to isolate it due it is in a carrier frequency of 5GHz. To obtain the bandwidth we are interested on, we have to multiply the signal by $e^{i2\pi\nu_0 t}$. Once we have isolate the bandwidth we are interested on, this will be located around the zero frequency, before the isolation it was a real value, and now it is a complex value.
- Digitize. This process it is made on board on the satellite. The lowest rate to digitize the signal according to the Nyquist theorem it is twice of its bandwidth, in this case it would be around the 30MHz. The image it is digitized at 5bits per pixel and once it is in the ground it is expanded to 8 bits = 1 byte for programming inconvenience.
- Range compression. This first process it is done to minimize the amplitude of the pulse which has been sent to the ground to acquire the data. To do that the use of the Fast Fourier transform will work perfectly.
- Patch processing. This process it is done to focus the image instead of by rows to columns. The image must be focused in the azimuth direction. Using the fast Fourier transform the process it is done easily. The amount of data to process it is quite high but nowadays with any multiprocessor computer the process can be done easily, in that case the file had to be cut.
- Range Migration. This process goes after the range compression and the patch processing. For each pixel which has been interchanged (columns rather than rows) the range migration will be done. The aim of this step it is to focus the image along the column. As the point target moves through the synthetic aperture (which has its own ground track velocity), it describes a hyperbolic shaped movement. This movement can be defined as a linear trend plus a hyperbola. Before the image it is focussed in the column a range migration must be done. The best way to focus the image it is by Fourier transforming the columns. As each component has its unique Doppler shift, all the components will have to migrate, both the ones which have positive and the ones which have negative Doppler spectrum.
- Azimuth Compression. The final step in the processing relies on calculating the shape of the aperture for a given illumination pattern. This process depends on the generation of a second chirp, which parameters depend on the velocity of the space craft, the PRF (pulse repetition frequency) and the absolute range. In this case the chirp is Fourier transformed into Doppler space and this value will be multiplied by each column range-migrated data. To get the focused data with these values the IFFT (inverse fast Fourier transform) will be done.

SLC Image. The data extract after all these operations will be written in a file, which will be easily seen in one of the plot functions MATLAB has.

1.2.- TERMS OF REFERENCES

Defining the scope in which the project will be done, we start from the premise that it will be a research project, based on the information available in the library and internet source. The program which is going to be used to treat the images is the MATLAB, this program works perfectly due it is a numerical computing environment and programming language which allows you to manipulate matrix, plotting of functions and data, implementation of algorithms and create your own code. That program is quite complex and wide so it will be useful to know what kind of functions and statements will be useful for this kind of project, and study them in depth. It will also be necessary to find and understand any other code created to plot the satellite data.

The main vision of this project might be based in the deeply interest MATLAB offers. As it is one of the most useful programs used lately. The image processing toolbox that MATLAB offers it is a really interesting tool to know how it works. And however the applications of the satellite images are out of this project, it would be really interesting to consider that point of the project and all the applications for which is useful such as navigation and guidance, foliage and ground penetration, moving target indication and many more.

The main objectives at the end of this project will be the understanding of decoding image satellite information in MATLAB code and improve the knowledge of such program.

The useful resource for a correct realization of this project will just be based on MATLAB program, which provides us the correct tools to develop a proper code and the mathematics requirements to treat all the data. With this program it will also be able to extract and plot the result images.

CHAPTER 2: FINDINGS AND ANALYSIS

2.1 Radar

2.1.1 Brief History

Radar beginnings are based on the electromagnetic waves behaviour, proposed by James Clerk Maxwell in 1864. Heinrich Hertz was the first one to demonstrate these laws in 1886 with his physical experiments. And the first one who suggested take advantage of the echo in the naval navigation was Christian Hülsmeier. On the other side Guglielmo Marconi develop an instrument with the same characteristics [1].

The first successful experiment was developed by Edward Victor Appleton, who used the echo of the electromagnetic waves to check the height of the ionosphere (that would be the highest layer which scatters the radio waves) [1].

One of the advantages of the British in the Second World War was thanks to Robert Watson-Watt, whose contribution with the first useful system of radar built in 1935, help the country to detect aerial and naval invasions in the southern coasts. At the same time two British scientists, Henry Boot and John T. Randall, invented the electrons pipe, this pipe was able to generate high power high frequency radio waves, fact which help to develop the microwave radar, able to work in tiny wavelengths, lower than 1cm, using laser. This type of radar it is very useful in the telecommunication field to measure pollution [1].

The first one who demonstrates the interferometric SAR by using an airborne was Graham in 1974. By using two vertically separated antennas and receive simultaneously backscattered signals from the terrain. In this case the vectorial addition of this signals produced a pattern of nulls corresponding to predetermined depressions angles, which, when used in conjunction with range information, yielded elevation information [2].

Goldsten and Zebker in 1987 used two horizontally separated antennas to receive backscattered signals from the moving sea surface to measure the radial velocity. They processed the signals separately to form two complex images, which they then combined interferometrically. They were able to show that since radial motion of a surface scattered causes a phase difference between the two images that is proportional to the distance moved, scattered motion can be measured [2].

Finally the first who demonstrated single-antenna, repeat-pass interferometry by using data collected on two separate passes of the Shuttle Imaging Radar, were Gabriel and Goldstein in 1988. Despite the fact that the orbits suddenly changed the direction refocusing and registered carefully the image, they obtained an altitude map of the imaged region [2].

2.1.2.-Basic Concepts

The operation of the RADAR's (RADio Detection And Ranging) consists of a pulse radiated into the free space through an antenna. The electromagnetic energy propagates outward at light velocity, scattering from all the objects finds on its way. The objects can be detected because the energy they scatter imitates the frequency and the duration of the transmitted pulse and provides the information on:

1. - magnitude
2. - phase
3. - time interval between pulse emission and return from the object
4. - polarization
5. - Doppler frequency

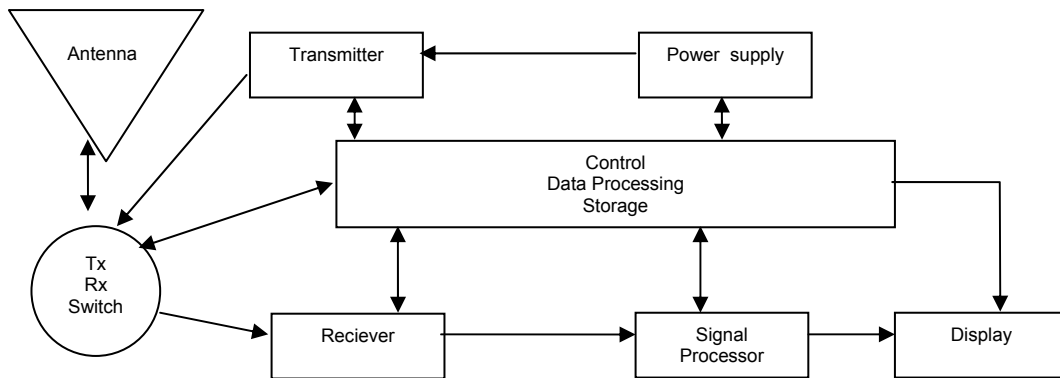

Fig.1

Fig. 1 shows the main scheme to obtain a signal and the way to process and obtain information.

- The range to a detected object can be calculated by the equation:

$$R = \frac{ct}{2} \quad \text{Eq.1}$$

R = range from radar to object
c = the velocity of light
t = the elapsed time

- The wavelength of the propagated energy is:

$$\lambda = \frac{c}{f} \quad \text{Eq.2}$$

f = frequency of the sinusoidal oscillator

To determinate the radar range equation first we have to determinate the energy density received at range R from the source:

$$\frac{P \tau G_T}{4\pi R^2} \quad \text{Eq.3}$$

If we compare the amount of energy a target intercepts and reradiates to that of a perfectly conducting sphere of unit radius, assign a radar cross section σ , to the target. The energy reradiated from the target then is:

$$\frac{P \tau G_T \sigma}{4\pi R^2} \quad \text{Eq.4}$$

If we assume that the transmitter and the receive antenna are collocated, the signal now arriving at the receive antenna, assuming it has an effective area, A_r , is:

$$S = \frac{P \tau G_T A_r \sigma}{(4\pi)^2 R^4} \quad \text{Eq.5}$$

As said before that would be the signal which arrived at the receiving antenna if we didn't consider the noisy. In a telecommunication system there's always noise energy contaminating the signal which arrives in the antenna. If we have to consider this noise produced by the earth's atmosphere, the amount contributing to the range equation is a product of the Boltzmann's equation ($K = 1.38 \times 10^{-23} \text{ J/}^\circ\text{K}$), the measured temperature in Kelvin degrees T_s , and if the various losses that exist in the system can be lumped together in a term L_s , the radar range equation can be written as:

$$\frac{S}{N} = \frac{P \tau G_T A_r \sigma}{(4\pi)^2 R^4 K T_s L_s} \quad \text{Eq.6}$$

The gain of an antenna is directly related to its effective aperture:

$$A_r = \frac{G_r \lambda^2}{4\pi} \quad \text{Eq.7}$$

Where G_r is the gain of the receive aperture and λ^2 the radar signal wavelength squared.

We can also define the G_T as the gain of the transmitter antenna which is defined as:

$$G_T = \frac{4\pi}{\theta^2} \quad \text{Eq.8}$$

For a transmitting antenna gain is simply a measure of how much focusing of the energy is being accomplished: Ratio of the solid angle contained in a sphere to the solid angle in which the antenna is squirting energy. Stated another way it is the ratio of the spherical area, 4π steradians, to the beam area of the antenna, θ^2 [3].

2.1.3.- Doppler Effect

In 1842 Christian Doppler, an Austrian mathematic and physicist wrote his monograph 'On the coloured light of the double stars and certain other stars of the heavens'. In this monograph he talked about the shift in frequency and wavelength of waves which results from a source moving with respect to the medium, a receiver moving with respect to the medium, or even a moving medium.

It is not the perceived frequency than the actual frequency, if the source or the observers have velocity. Christian Doppler defined his equation as:

$$f' = f_0 \left(\frac{v \pm v_o}{v \pm v_s} \right) \text{ Eq.9}$$

f' = perceived frequency

f_0 = actual frequency

v = speed of the waves in the medium

v_o = relative speed of the observer

v_s = relative speed of the source

The symbol which is plus and minus depends on who of the sources (the viewer of the observer) is moving towards which or maybe remaining on the same place [4].

For the SAR images that later will be treated with MATLAB, this effect must be considered. The chirp which is sent to the ground it is sent from a space craft. This space craft has its own velocity due it is following a geostationary orbit. Moreover, the earth, place where the chirp has been reflected, it has also its own movement. So for this reason the Doppler Effect must be considered due the signal which is going to be received won't follow a linear trajectory. The motion of the source causes a real shift in frequency of the wave, while the motion of the observer produces only an apparent shift in frequency.

2.2.- Types of Radars

There are two main radars we could define:

- The passive radars are those which get the radiation levels of the objects in their natural environment.
- The active radars are those which emit microwaves pulses in the direction these want to get the information and then store the energy scattered.

According to the antenna's size, we also can divide them in two main groups:

- o RAR
- o SAR

2.2.1.- RAR (Real Aperture Radar)

RAR or non-coherent radars are the kind of radars which are controlled by the physic length of the antenna. It is active radar because it emits little pulses of energy transmitted from the radar antenna to the piece of terrain which we want to obtain the image.

Reflections from larger ranges arrive back at the radar after proportionately larger time, which becomes the range direction in the image. When the next pulse is transmitted, the radar will have moved forward a small distance and a slightly different strip of terrain will be imaged. These sequential strips of terrain will then be recorded side by side to build up the azimuth direction. The image consists of the two dimensional data array.

Its design and data process make them easy to use. Although their near range resolution it is poor, it works perfectly in low height missions or low wavelengths. So the use of its data for the atmospheric or scattered studies would be quite difficult, due to its low height flights.

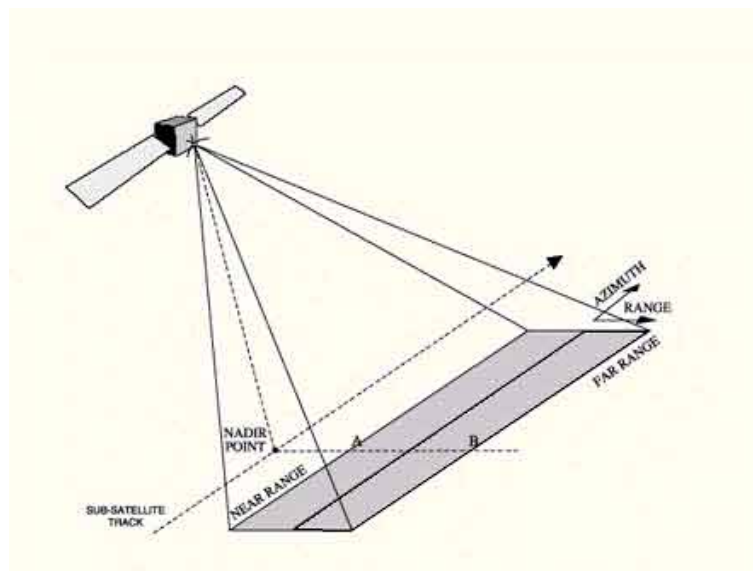

Fig.2

Fig.2. the strip of terrain to be imaged is from point A to point B. Point A being nearest to the nadir point is said to lie at near range and point B, being furthest, is said to lie at far range.

The distance between A and B defines the swath width. The distance between any point within the swath and the radar is called its slant range. Ground range for any point within the swath is its distance from the nadir point (point on the ground directly underneath the radar).

Image resolution will be determined by the own antenna's length. To reduce the bandwidth of the emitted signal the antenna must have at least several times the length of the wavelength, so due to this reason, it is not practical the design of a large antenna to get a better resolution of the image.

2.2.2.- SAR (Synthetic Aperture Radar)

These systems are coherent radars which generate high resolution images. Synthetic aperture means that the image which is produced it is the result of consecutive and coherent signals, which are transmitted and received in a little antenna which is moving along the orbit or flight route. To process the signal it will be used the magnitude and the phase of the signal received.

During the flight of the spacecraft which contains the radar, several pulses are transmitted, and the result of the larger image it would be the distance between each signal emitted as if it was a larger antenna of the size of each transmitted pulse.

These types of sensors operate in the microwave region of the electromagnetic spectrum with typical wavelengths between 1cm and several meters. It is an active system, because it emits by itself microwave radiation to the ground and measures the electric field backscattered by the illuminated ground patch. These measurements are transformed into a high resolution images available equally well during day and night.

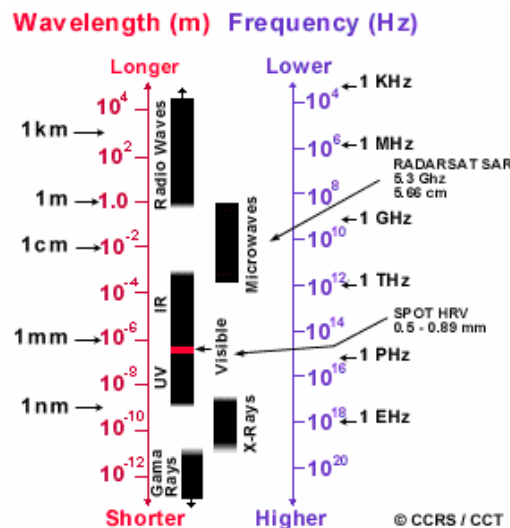

Fig.3

Fig.3 where it is shown the electromagnetic spectrum

Earth's atmosphere is nearly transparent in the microwave region. These which have wavelengths longer than 1cm even permeate almost undisturbed small water drops. Thus the operation of a SAR is possible even in the presence of clouds, fog and rain, which are a limiting factor in optical remote sensing. So combining weather independence with day and night operation

capabilities makes SAR an operational monitoring device for the entire earth's surface, a task which could not be achieved with optical sensors.

Radar images contain quite different information than images obtained from optical or infrared sensors. While in the optical range mainly molecular resonances on the object surfaces are responsible for the characteristic object reflectivity, in the microwave region dielectric and geometrical properties become relevant for the backscattering. These emphasize the relief and morphological structure of the observed terrain as well as changes in the ground conductivity, because of the sensitivity to dielectric properties, these also can provide information about the condition of vegetation, an important fact for agricultural and forestry applications.

Another important feature of SAR data results from the propagation characteristics of microwaves. Due to their long wavelength, microwaves are capable to penetrate vegetation and even the ground up to a certain depth.

In a radar system, the resolution can be determined by the pulse length and the width of the beam which comes from the antenna. Pulse length determines the resolution in the energy propagation (range resolution) the shorter these are the highest resolution in range. Beam's width determines the azimuth resolution. So, these two requirements mean that the resolution is proportional to the antenna's distance [5].

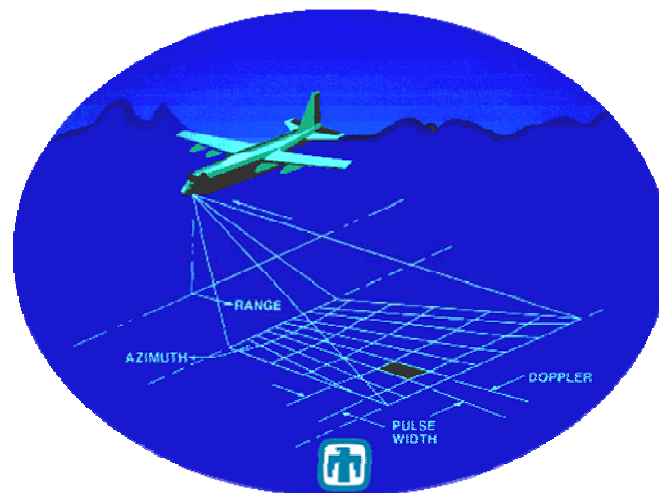

Fig.4

Fig.4 shows the range and azimuth parameters from a SAR space borne.

2.2.2.1.- Range Resolution

The range resolution is determined basically, by the time in which the echo of a beam sent to the ground takes to come back to the satellite; once it has reflected the scattered ground. It depends on the pulse length duration and is completely independent of the spacecraft height.

If there are two points illuminated by the radar beam, if these are separated by the duration of the transmitted pulse, we would be able to distinguish their echoes, otherwise not.

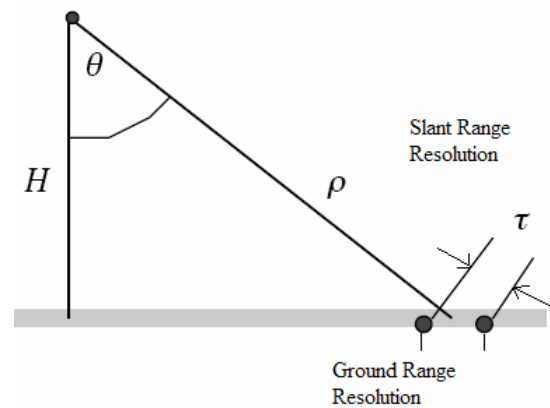

Fig.5

Fig.5 ground Range resolution vs. Slant Range resolution.

Slant Range Resolution (distance of two different points to the radar)

$$\Delta r = \frac{c\tau}{2} \quad \text{Eq.10}$$

Ground range resolution (distance between two points in the ground)

$$R_r = \frac{c\tau}{2 \sin \theta} \quad \text{Eq.11}$$

c - speed of light

θ - look angle

τ - pulse length ($1/B$)

2.2.2.2.- Azimuth resolution

The other dimension to consider will be the azimuth resolution, this is perpendicular to range. As seen before this doesn't depend on the height of the spacecraft and it just depends on the sharpness of the beam. SAR radars produce relatively fine azimuth resolution; due the length of their antennas it is not large. The resolution of a simple side-looking radar will be the size of its footprint on the ground. The angular resolution of an antenna of length L in the azimuth direction is limited due to diffraction effects on its aperture, if the wavelength of the radar it is λ :

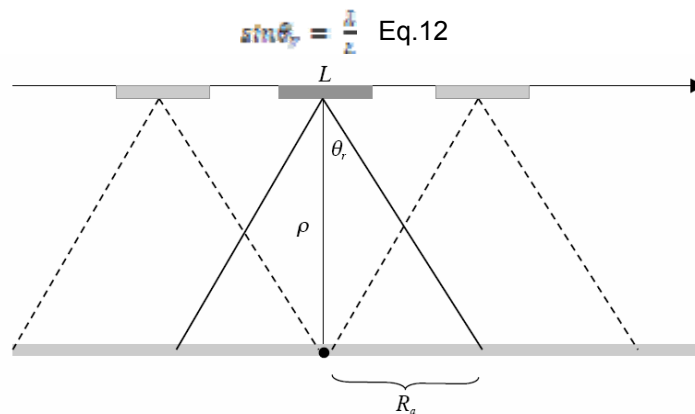

The spatial resolution at a given range will be:

$$R_a = \rho \cdot \sin\theta_r = \frac{\rho\lambda}{2L} \quad \text{Eq.13}$$

If we have to consider a synthetic aperture radar its length it is $2R_a$, and the improved azimuthal resolution it is:

$$R_a' = \frac{\lambda\Delta x}{2R_a} = \frac{\lambda}{2} \quad \text{Eq.14}$$

Where ρ is defined and H is the height of the spacecraft.

$$\rho = \frac{H}{\cos\theta} \quad \text{Eq.15}$$

Resolution for ERS SAR

For the data downloaded the satellite specifications of bandwidth, antenna length and look angle are calculated below:

Bandwidth of ERS SAR. $BW = 15.6\text{MHz}$
Antenna length $L = 10\text{m}$
Look angle $\theta = 23^\circ$

Based on these parameters we can calculate the slant range resolution as:

$$\Delta r = \frac{cT}{2} = \frac{c}{2BW} = \frac{3 \cdot 10^8 \text{m/s}}{2 \cdot 15.6 \text{MHz}} = 9.61\text{m} \quad \text{Eq.16}$$

Ground range resolution:

$$R_r = \frac{cT}{2 \sin\theta} = \Delta r \frac{1}{\sin\theta} = 24.608\text{m} \quad \text{Eq.17}$$

Azimuth resolution

$$R_a' = \frac{\lambda}{2} = \frac{60}{2} = 3\text{m} \quad \text{Eq.18}$$

For the PRF we have to consider a value between two parameters:

$$\frac{2V}{L} < PRF < \frac{c}{2H} \left(\frac{1}{\cos\theta_2} - \frac{1}{\cos\theta_1} \right)^{-1} \quad \text{Eq.19}$$

V = spacecraft velocity relative to the ground

C = carrier frequency
 $\Theta_1 = 18^\circ$
 $\Theta_2 = 24^\circ$

According to these values:

$$1425 < PRF < 4777 \quad \text{Eq.20}$$

2.2.2.3 SAR applications

First SAR applications were military, but now the main applications are civil, some of them are described:

- Military services

Reconnaissance, surveillance and targeting of a selected point as SAR can provide day-and-night imaging, to distinguish terrain features and recognize military staff. It is also used for the non-proliferation of nuclear, chemical and biological weapons.

- On the oceans

Detection of sea changes, from man-made illegal or accidental spills, the natural seepage from oil deposits, the detection of ships, the backscattered from the ocean surface to detect wind or current fronts or internal waves. In shallow waters it is able to detect bottom topography, also with the ERS altimeter, the scientists can define the sea bottom due the surface refraction has variations of the surface height, and eddies detection.

If we talk about the wave mode sensor in the ERS SAR satellite, it can provide the scientists of ocean wave direction to make wave forecasting and obtain marine climatology information.

At high latitudes, SAR can detect the ice state, its concentration, thickness, leads detection.

- On the land:

In forestry and agriculture, SAR images are really important due the wavelength can penetrate the clouds in the most problematic areas, such as the tropics, monitoring the land and its state.

Geological and geomorphological features due the waves can penetrate some vegetation cover and obtain information about the surface covered by it.

To georefer other satellite imagery updating some thematic maps more frequently.

SAR it is also useful to check the aftermath of a flood to assess quicker the damages.

- On the atmosphere:

Check ozone levels in the whole stratosphere.

Interferometric SAR (InSAR), by this new application it is able to get DEM or detect some surface movements which can give the scientists, clues for earthquakes detection due few centimeters movements. During ERS-1 and ERS-2 tandem (which last 9 months) this technique took much more development strength.

2.2.3.- InSAR (Interferometric Synthetic Aperture Radar)

This technique combines the two main characteristics of each system. By the acquisition of the SAR images, each pixel phase which wasn't used to obtain any kind of information, now it is. By the interferometry technique it is able to find out the height of the object respect to the satellite or plane where the images are acquired. It uses the phase difference between two images to estimate it. Each pixel is the addition of two components: the specific phase – related with the surface nature- and the difference which depends on the distance between the radar and the surface. Superimposing and finding the difference between the two different images, the specific phase can be deleted. The resultant phase is the component due to the difference of the distance between the two steps of the satellite. With this interference image it is possible to find out the absolute height with variable precision due to different parameters.

2.3.- Satellites History ERS-1/2

2.3.1.- ERS-1/2

A brief about the satellite where the data has been downloaded from must be done to know the characteristics of it.



Fig.7

The ESA (European Space Agency) launched in 1991, ERS-1. The ERS-1 (Fig.7) was the first Earth observation satellite. The satellite design characteristics provided it to take service about: attitude and orbit control, power supply, monitoring and control of payload status, telecommunication with ground stations and telemetry of payload and platform housekeeping data. According to the last satellite launched by ESA, this satellite was modified to have higher extension of the solar array power and battery energy storage capability, the development of new software for payload management and control and the modification of the attitude control sub-system to provide yaw steering and geodetic pointing.

ERS-1 satellites' life finished after nine years of service, it exceed three times its planned lifetime and the 10th of March in 2000 it ended its services due a failure in the on board attitude control system. Before its failure, the 21st of April in 1995, ESA launched ERS-2. This satellite overlapped with ERS-1, but this satellite mission was to continue the ERS-1 work and provide it with much more equipment to improve the characteristics of the antique one. ERS-2 had almost the same characteristics as ERS-1, but ESA provided it with an additional sensor for atmospheric ozone research.

In the time both spacecrafts were launched, these were the most sophisticated Earth observers' spacecrafts. During the years these have been in orbit, they have collected a wealth of valuable data on the Earth's land surfaces, oceans, and polar caps and have been called upon to monitor natural disasters such as severe flooding, earthquakes, El Niño and so on.

In 1995 ESA decided to link both spacecraft, in what was the first tandem ever in the history. During the time these were linked the increased frequency and the level of data available to scientists offer them the unique opportunity to observe changes over a very short space of time, as both satellites orbited Earth only 24 hours apart.

Some characteristics of both satellites:

		ERS-1	ERS-2
Launch	From Kourou, French Guinea	17 th of July 1991	21 st of April 1995
Launcher	Ariane 4		
Launch mass		2384 kg	2516 kg
Number of instruments	4/5 including SAR with GOME added to ERS-2		
Orbit	Sun synchronous, altitude 800 km		
Inclination	98'5 degrees		
Time for one orbit	100 minutes		
Cycle	35 day repeat		

Table 1.

2.3.2.- ERS-2

This satellite it is nearly identical to ERS-1 as commented before. The platform is based on the design developed for the French SPOT satellite. A short overview on its On-board systems it is described:

AMI – Active microwave instrument consistent of a synthetic aperture radar (SAR) and a wind scatterometer (both in the C-Band).

RA – Radar altimeter, which takes precise measurements of the distance from the ocean surface and the wave heights.

ATSR- Along track scanning radiometer (it operates in the IR and Visible range), it measure surface temperature and the vegetation cover of land surfaces.

GOME- global ozone monitoring experiment, an absorption spectrometer which measures: the presence of ozone, trace gasses and aerosols in the stratosphere and troposphere.

MS- A Microwave sounder which supplies data on atmospheric humidity.

PRARE- Precise Range and range rate equipment ERS orbit and trajectory determination.

LRR- Laser reflector: determines satellite position using ground-based laser stations.

IDHT- Instrument data handling and transmission: temporary on-board data storage by means of two 6.5GBit tape recorders, equivalent to the data volume acquired in one orbit. Recording, formatting and transmission of data at 105Mbit/s.

The ERS-2 Active Microwave Instrument (AMI) operates at 5.3GHz (the C-band of the radio electric spectrum), it combines the functions of a SAR (Synthetic Aperture Radar) and a WNS (Wind Scatterometer).

ERS-2 (Fig.8) contains 4 antennas, three for the Scatterometer and one for the SAR. The Earth's surface illuminated and the backscattered energy is received to produce data on wind fields and wave spectra, and to prepare high resolution images.

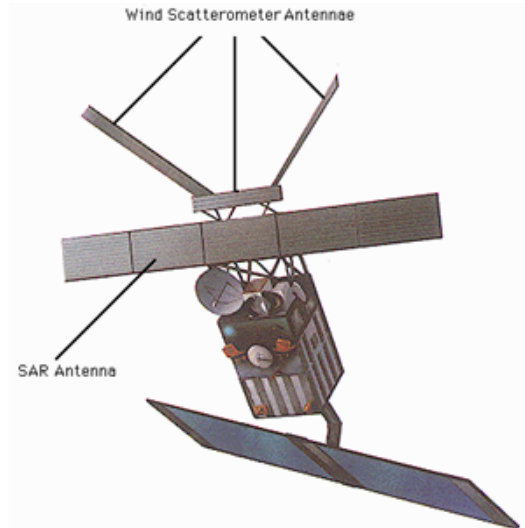

Fig.8

The characteristics of this space craft and the operational capabilities of the AMI equipment, provide this satellite to get the following:

- The SAR in image can operate 12 minutes per orbit.
- In wave and wind measurement interleaved mode the AMI can operate continuously.
- The simultaneously between the SAR and the Wind Scatterometer it is not possible.

The main characteristics of the AMI antenna which are important for that project would be the following:

Frequency: 5.3GHz (C-band)
 Bandwidth: 15.5 MHz +/- 0.1MHz
 Peak power: 4.8 KW
 Polarisation: Linear Vertical
 Incidence angle: SAR 23° nominal
 Transmit pulse width: 37'12 +/- 0.06 μs (SAR); 70 μs and 130 μs (WNS)
 Quantisation: SAR image mode 5I, 5Q OGRC (On Ground Range Compression); 6I, 6Q OBRC (On Board Range Compression). [6]

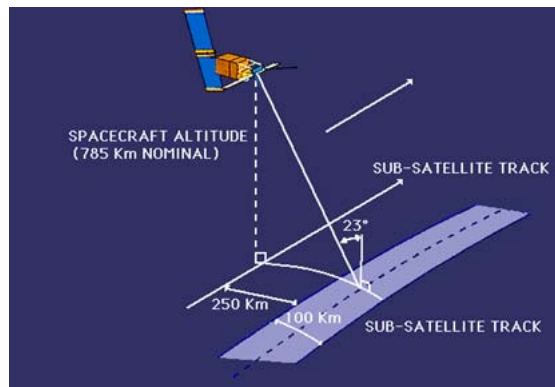

Fig.9

Fig 9. It is shown the space craft characteristics, range resolution, incident angle, height, and width surface scattered

CHAPTER 3: EXPERIMENTAL PART

3.1.-Digital SAR Processor

The complete procedure to get the SLC in Fig.10; it contains all the steps which must be done in the MATLAB code to obtain the expected image.

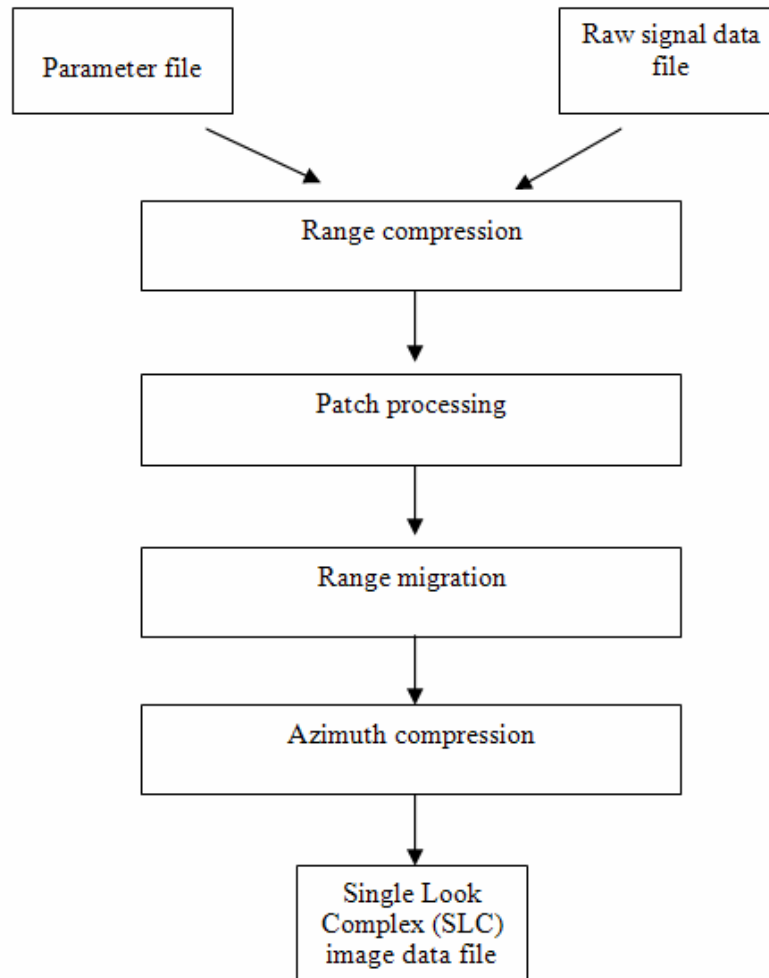

Fig. 10

From the data provided we have to set some parameters in the MATLAB command which belongs to the first part of the .raw file. These parameters set the variables with which we will work later to construct and get the SLC image. The raw data is all the data which has been scattered from the earth to the satellite. These data is commonly complex numbers, with the real and the imaginary part, or otherwise parts of the signal as the in-phase (I) and quadrature (Q) components. The part of the file which contains all these data has 11644 bytes, from which 412 bytes are the timing and the 11232 bytes contain the 5616 complex numbers [9].

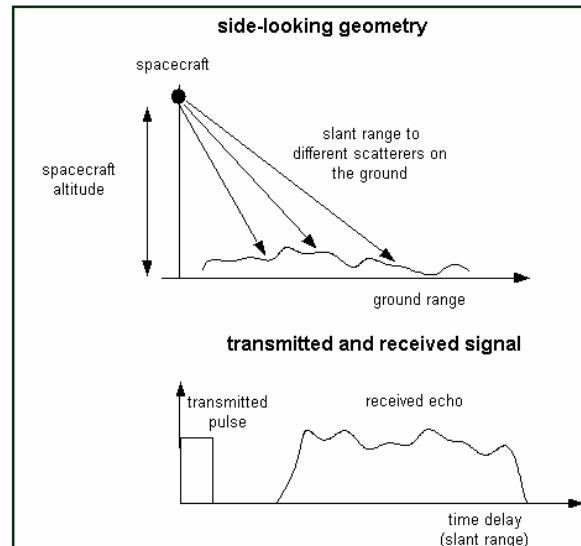

Fig.11

- The range (Fig.11) compression it is performed on each radar echo. The aim of the range compression it is to reduce the power of the peak emitted by the radar done with the fast Fourier transform.

To deconvolve the chirp (Fig.12) the filter used it is the complex conjugate of the chirp. So if the frequency-modulated chirp has an equation as:

$$s(t) = e^{j\pi kt^2} \quad \text{Eq. 20}$$

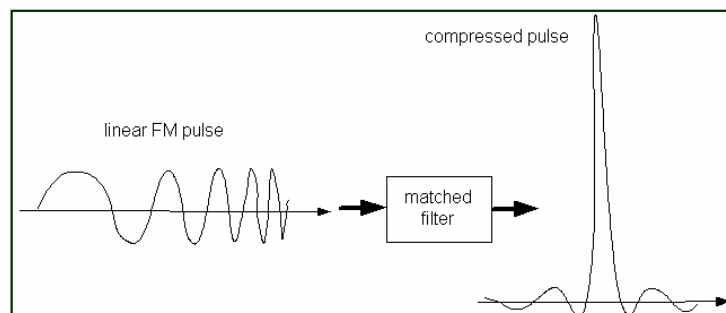

Fig.12

Its conjugate chirp and consequently the filter will be

$$s(t) = e^{-j\pi kt^2} \quad \text{Eq.21}$$

- The patch processing it is done to focus the image in the azimuth track, this time instead of using rows, columns must be proceed.

- Range migration. This process it is called once we want to define the target point. This target follows a hyperbolic-shaped reflection (in Fig.13) due it is moving through the synthetic aperture. To define its movement we will define it as linear trend

trajectory plus a hyperbola. This proves involves the way to bring back to a constant range cell to focus the image along the single column which fits better the characteristics of the target point. The range migration must be done to each pixel of range compressed data whose columns have been fast Fourier transformed. If we were talking about ideal radar, the first component would have a zero Doppler frequency, and the point would be perpendicular to the space craft velocity vector. The second point would have a positive Doppler shift, so that's why we have to do the range migration to each cell, all this process will have to be done to each cell, the ones which belong to the positive Doppler shift and to those which belong to the negative Doppler spectrum.

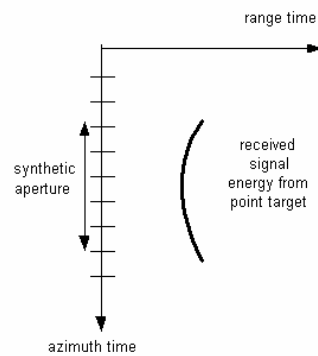

Fig.13

- Azimuth compression. The aim of the azimuth compression it is due the radar pulses received contained the echo of a single point target. So due to that the image it will be defocused. The received energy of the target will be distributed, so the focussing of the illumination time must be focussed on one point, this will be the $t=0$. It involves the generation of a second frequency modulated chirp based on the knowledge of the space craft orbit. The parameters which will be needed to do that will be the pulse repetition frequency (PRF), of course the velocity of the space craft and the absolute range. By Fourier transforming the chirp into Doppler space, it will be multiplied by each column of the range migrated data. Once this is done, the inverse Fourier transformed will be done to provide the focused image. Now the equations which provide the useful information to do this process

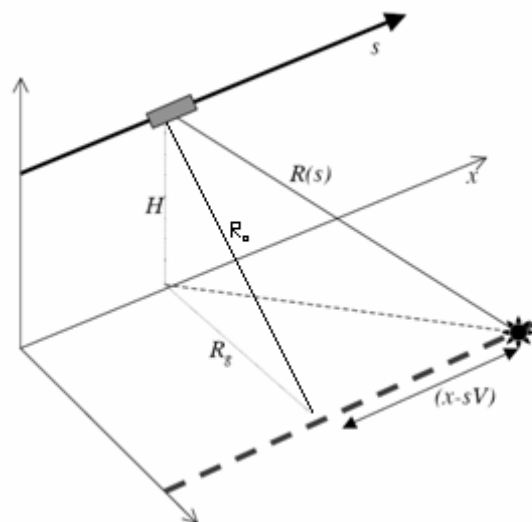

Fig.14

In Fig.14 if we assume that:

- s = slow time along the satellite track
- x = ground track position
- V = ground track velocity

s_0 = time when the target is in the centre of the radar illumination pattern
 H = space craft height
 R_g = ground range
 $R(s)$ = range from the spacecraft to target

According to Fig.14 the equations for the azimuth compression can be defined.

$$R_0 = \sqrt{H^2 + R_g^2} = R_{near} + n * C/f_s \quad \text{Eq.22}$$

The complex phase of the return echo is:

$$C(s) = \exp \left\{ i \frac{4\pi}{\lambda} R(s) \right\} \quad \text{Eq.23}$$

The range is

$$R^2(s) = H^2 + R_g^2 + (x - sV)^2 \quad \text{Eq.24}$$

That equation it is a hyperbola, so the approximation with a parabola can be made:

$$R(s) = R_0 + R_0'(s - s_0) + \frac{R_0''}{2}(s - s_0)^2 + \dots \quad \text{Eq.25}$$

After several calculations for the derivative of the equation respect s (which is the slow time along the satellite track), the complex phase can be written as:

$$C(s) = \exp \left\{ i \frac{4\pi R_0}{\lambda} \right\} \exp \left\{ i 2\pi \left[\frac{-2V(x - s_0V)}{\lambda R_0} (s - s_0) + \frac{2V^2}{\lambda R_0} (s - s_0)^2 / 2 \right] \right\} \quad \text{Eq.26}$$

In this function we can find the Doppler centroid frequency and the Doppler frequency rate:

$$f_{DC} = \frac{-2V(x - s_0V)}{\lambda R_0} \quad \text{Eq.27}$$

$$f_R = \frac{2V^2}{\lambda R_0} \quad \text{Eq.28}$$

Both frequencies depend on the space craft ground velocity, the wavelength, the minimum distance from the spacecraft to the target (R_0) and a factor called the squint angle which is $\frac{x - s_0V}{R_0}$.

To calculate the parameter R_0 it will be the range to a particular column in the raw signal data file:

$$R_0 = R_{near} + n \left(\frac{c}{f_s} \right) \quad \text{Eq.29}$$

R_{near} it is the near range to the first column of the raw signal data file, n it is the column proceed, c is the speed of light and f_s is the frequency sampling rate given before.

The length of the synthetic aperture depends on the length of the radar ground footprint in the azimuth direction:

$$L_a = R_0 \frac{c}{f_s} \quad \text{Eq.30}$$

	V(m/s)	λ (m)	PRF (Hz)	R_0 (km)	L(m)	L_a (m)	n_a theory	n_a actual
ERS-1/2	7125	0.057	1679	850	10	4850	1142	1164

Table 2. Values for the ERS-1/2

According to the parameters found in the raw file downloaded the $f_{DC} = 284$ and the $f_R = 2104.8$.

At the end we just have to study the squint angle, which is the $\frac{x - s_0 V}{R_0}$

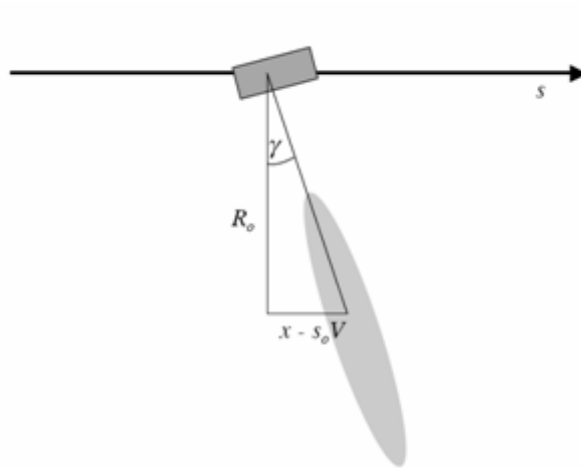

Fig.15

According Fig.15 the squint angle will be:

$$\gamma = \tan^{-1} \left(\frac{x - s_0 V}{R_0} \right) \quad \text{Eq.31}$$

One of the characteristics of the ERS-2 satellite it is that the squint angle it is adjusted, so that means that the zero Doppler occurs in the middle of the antenna beam pattern [9].

3.2.- Software's

3.2.1.- Software's to treat the images

There are several software's to treat the images available in internet. Once you get into all the information available in the internet source, once realize that the image processing types are as wide as the programs which are available. From the web pages recommended, we found free software programs or commercial SAR software.

Some of the free SAR software's are described:

- ASF tools. This software would be to convert and geocode some of the Alaska satellite Facilities
- BEST. Basic Envisat SAR Toolbox. Some executable software developed by ESA to treat the images acquired by their satellites, such as ERS-1 (off service nowadays), ERS-2 (substitute of ERS-1 with almost the same characteristics) and Envisat which is the last satellite in orbit from ESA.
- DORIS. Software to treat, InSAR or DInSAR images, provided by the Delft Institute for Earth-oriented Space Research
- IDIOT. Software developed in Berlin University of Technology to treat DInSAR images, quite easy to use.
- PolSarPro. With the support of ESA and developed in the University of Rennes, this software it is to process polarimetric SAR data.
- Radarworks Toolbox. This is a toolbox for MATLAB, to treat polarimetric SAR data.
- RAT (RADAR Tools). Another software developed in the Berlin University of Technology to treat all kind of satellite images such as SAR, InSAR, PolInSAR, PolSAR.
- ROI PACK. This is for interferometric SAR processing

These would be the commercial software's available in the net and recommended in the epsilon.nought.de web page:

- DIAPASON. Differential Interferometric Automated Process Applied to Survey of Nature, software to treat mostly the DInSAR images.
- Earth View. This software it is for SAR and InSAR processing.
- Gamma Remote Sensing. Complete software to treat SAR, InSAR, DInSAR images.
- InfoPACK. Usefull for SAR data.
- Photomod Radar. Space borne SAR data processing
- SARscape. Specialized ENVI extension for processing SAR/InSAR data.

A part of the software's commented to treat the images, due the file which was downloaded contain too much information to process the data in a personal computer the use of Cygwin was indispensable to cut the file into the appropriate length.

Cygwin it is an environment for Windows acting the UNIX or LINUX environment. It is a free software developed by Cygnus Solutions. This program provides the user some header files and libraries that makes it easy to recompile or port Unix applications for use on Windows. The maintenance of this program it is done by Red Hat or NetApp users. It is released by the GNU (General Public License).

This software contains solutions for any PC, to fix problems within the UNIX/Linux shell, it is able to run shell command scripts, sophisticated shell commands scripts can be created with standards shells. It is able also to administer the Windows system.

The main function used with Cygwin was the 'dd'. This command used in the shell provides the user to read and copy a file while also providing some useful tools to treat the file. The main functions used while reading and writing the file were: the option which provides the user to select the moment in which you want to start to read the file (due that there was some information which wanted to be skip), the option which provides the user the possibility to choose the length of the file, the input file from where the information must be read, and the output file where the user wants to save the data selected.

The command introduced in the shell was the following:

```
dd if=mire of=out.raw count=58220
```

if: this is the option which provides the user to select the input file, in this case mire.

of: this is the option where you can choose the output file to copy the data selected, in this case it will be the out.raw.

count: with this option the user can copy the blocks (bytes) from the input file, instead of everything until the end of the file.

3.2.2.- MATLAB as the best Software

Once seen all the software's available to treat that kind of images, the aim of this project a part of being how to develop a code to process SAR images, it is also to understand and improve the knowledge about MATLAB, this useful tool in matrix and acquisition of data.

MATLAB it is one of the best programs available at the moment which provides almost all the tools to treat images, due it is a powerful program of matrix treatments. In the beginning of the project it was agreed about the use of this program. The wide of utilities this program provides made it really interesting to study. Since the beginnings of this program the opportunities it offers to treat all kind of data, from sound, images and any kind of signals, it was the point to decide to use it for the project. This program provides the user to program at a high level language, develop the proper functions to treat the data acquired from an external source, and plot the results expected.

MATLAB provides the user to create the .m files. Those kinds of files are executables which accept in/out arguments. The user must define the function and the process it has to do to obtain any result, but these doesn't work in the workspace, the intern variables are locals in the function. The functions defined in the .m file can be used several times in the workspace, and their use it is to optimize several operations which must be done in the workspace, these functions can be called in the workspace as any other function defined by MATLAB, such as any fft or any function which is provided by the own program. For this project it will be really useful due that there are some functions which have to compute and realize the fft of the matrix that contains the data which must be treated to obtain the SLC image. The functions which are going to be created in the .m files will be the function which opens the .raw file to extract the proper data we need to treat to obtain the image. Another function will be the one which computes the ERS chirp and its Fourier Transform. And finally the last function created in MATLAB will be the one which computes the ERS azimuthal chirp and also computes its Fourier Transform.

The command window for the MATLAB tools doesn't accept in/out arguments and works with the variables defined in the workspace. These are useful to convert automatic some steps which must be done several times. To treat the SAR images, as we will see in the part of the project code in MATLAB, the main functions which have to be used are the fast Fourier transform, this program has this function as a default in it, so it won't be a problem to use them in each case we have to.

3.2.2.1.- Main functions

This chapter must contain all the functions described and created in MATLAB to treat the SAR images. The main functions created to treat these images are the following:

- Open the file to extract the data from the files downloaded which contain the satellite data. Usually the data provided in these files contains the characteristics of the satellite in which took the image. As commented before in the data obtained it must contain some information which helps and guides us to extract and give the correct parameters to MATLAB for its correct unpacking. The file downloaded it is a raw file. These types of files are image files; all the user photographic cameras have the option to get that kind of files. These files contain the camera settings (such as sharpening level, contrast, saturation, colour, temperature, white balance and so on), but in this case all the satellite settings will be the spacecraft velocity, moment in which the chirp has been sent to the earth, number of bytes of the file and so on. This function must open the file, and extract the data we are interested on, it must also count the number of bytes the file has, the number of columns and rows the matrix has and extract from each number the real and imaginary part and after remove the mean value.
- Function for the range resolution. In this function we have to be able to compute the ERS chirp and its Fourier transform. We have to compare the data obtained with the reference values calculated before, and make the fft of the data.
- Function for the azimuth resolution. As the one before, now instead of compute the range resolution, we have to compute the azimuthal resolution and its Fourier transform.

3.2.2.2.- Data obtained

The data we want to visualize in MATLAB it is in a raw file. These image files contain the main characteristics in which the photo or image was taken.

According to the file downloaded, first of all we had to decompress the file as it was a gz file, with the typical WinRAR the decompression was done easily. From this file we have to consider that the main parameters to set in MATLAB are on the first 412 bytes of each line of the file, the other 11232 bytes are the data we must read to acquire a SLC image, this will be 5161 complex numbers. According to these values each line of the file contains 11646 bytes.

ESA provides the users of a complete file to understand, set and identify all the parameters of this first 412 bytes [9] [11].

File information/ format

input file	e2_10001_2925.fix	name of raw data file
SC_identity	2	(1) – ERS-1 or (2) – ERS-2
Bytes_per_line	11644	number of bytes in row of raw data
first_sample	206	there are 416 bytes of information to avoid
fd1	248.115	Doppler centroid estimated from the data f_{dc}
I_mean	15.504000	mean value for the real numbers
Q_mean	15.549000	mean value of the imaginary numbers
icu_start	2576039268.848	spacecraft clock for the first sample
SC_clock_start	1997078.767881851	UTC for first sample YYYYDD.DDDDDDDDD
SC_clock_stop	1997078.768074699	UTC for last sample YYYYDD.DDDDDDDDD

Radar characteristics

PRF	1679.902394	Pulse Repetition Frequency	PRF
Rng_samp_rate	1.89625e+07	Range sampling rate	f_s
chirp_slope	4.17788e+11	chirp slope	k
pulse_dur	3.712e-05	pulse duration	T_p
radar_wavelength	0.056666	radar wavelength	λ

Orbital information

near_range	829924.365777	distance to the first range bin	R_{near}
earth_radius	6371746.4379	earth radius ½ way into image	R_e
SC_height	787955.52	spacecraft height ½ way into image	H
SC_vel	7125.0330	ground track velocity	V

Processing information

num_valid_az	2800	The size of patch to process
num_patches	10	The number of patches to process
first_line	1	
deskew	n	deskew (yes or no)
st_rng_bins	1	number of range bins in output file
chirp_ext	614	extend the chirp to process outside swath
Flip_iq	n	exchange real and imaginary numbers (yes/no)
nlooks	1	number of azimuth echoes to average

image alignment

rshift	15.1	range shift to align image to master
--------	------	--------------------------------------

ashift	483.2	azimuth shift to align image to master
stretch_r	.0014569	range stretch versus range
stretch_a	-.0019436	azimuth stretch versus range
a_stretch_r	0.0	range stretch versus azimuth
a_stretch_a	0.0	azimuth stretch versus azimuth

Moreover a part of the parameters file in the raw file, in the ESA there is the specification of the file, including all the bytes and the parameter which contains this file. The part in which we must focus it would be the part which contains the I and Q samples. By acquiring these data then all the process in MATLAB would start.

3.2.2.3.- Code in MATLAB

This part of the project it is to explain all the code in MATLAB which has been studied. In Fig.16 it is shown the overall process:

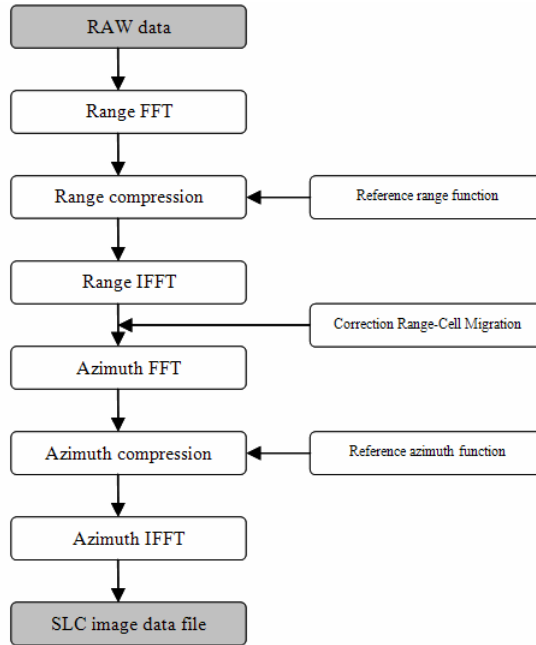

Fig.16

First of all we have to set the parameters in which the satellite image was acquired. As the first thing we have to do once we have the data is the range fft, these will be the first parameters defined in the code, after we also have to give some information about the azimuth parameters. These range parameters are the range sampling rate, the pulse duration, and the chirp slope. Once these are defined, now it is time to define the azimuth parameters, the pulse repetition frequency, the radar wavelength, and the space craft velocity.

As explained before in the part of the project of SAR and the range resolution, now it is time to compute the range to the radars reflectors. This is done by defining the near range distance and defining the slant range resolution. Once done that, the Doppler centroid frequency is defined as also the Doppler frequency rate which has been also explained before as twice the space craft velocity divided by the wavelength product range.

Once these parameters are defined in the MATLAB command window, it is time to get some data from the file downloaded. The data contained in the file it is the first 412 bytes of timing and the 11232 bytes (5161 complex numbers). Then it is when the function designed to get the data has to acquire the bytes of I and Q values. The file must be open and read the bytes. The bytes are defined as unsigned character; it means that these occupy 2 bytes per sample. During this process the number of rows and columns must be saved due later we also will need these values. In the same function we also have to acquire the real and imaginary parts of the values and remove the mean value. As told before the data we need from the file goes from the

413 byte to the 11643 byte, we have to scan all these bytes, and to take the mean value we subtract the mean value specified in the parameters file which is 15.5.

Once we have the data we can plot the results of the data acquired without making any kind of process to the data. This would be the image of the unfocussed raw data Fig.17

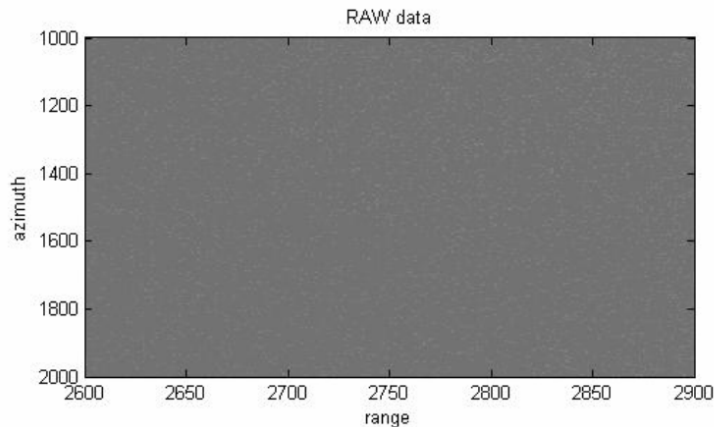

Fig.17

After acquiring the data and without taking any process on it this is the aspect it has. If we want to focus the image, first it takes part to generate the range reference function.

The range reference function, it is also a function created in the .m file. This function computes the ERS chirp and later makes the Fourier transform. As the values of the sampling frequency, pulse duration and slope were defined in the beginning of the code in the command window, now the only thing it is to take these values as variables for the function. The values which are needed to know for this function are the number of fft's which must be done, which number will be the same as number of columns (value which was acquired once the data has been read by the function read_rawsar), the range sample rate (value defined in the beginning of the code), the duration of the chirp (also defined), and the chirp_slope (also defined in the beginning of the code). Knowing these variables, now it is time to approximate the value of the product between sampling frequency and the pulse duration to the nearest integer less than or equal to their product and make it odd. Once that is done, we have to scan the array which goes from the number calculated before divided by two and multiplied by the inverse of the sampling rate frequency, from this number in minus, to the number in positive. This product it is the variable t. And each phase will be product between the number acquired before squared, multiplied by pi and the chirp slope. Then the fast Fourier transform would be performed for each value of the matrix created with the reference function and the values calculated.

Once again in the command window of the MATLAB, the fast Fourier transform of the data acquired from the file would be done. These data must be multiplied with the range reference function explained before.

The curl which is done, will set all the variables of the matrix at 0; we have to scan each value of the matrix from 1 to the total number of rows. The data acquired after making the fast Fourier transform (of

the SAR data) is copied in each column of the new matrix and each column must be multiplied by the value acquired in the range reference function. The result value is going to be saved in a new matrix. This curl will be done till all the rows of the first matrix will be completed.

Once the matrix of the product between the range reference function and the values of the SAR file are multiplied the inverse fast Fourier transform for the matrix is going to be done. We can plot the image, once the inverse fft is done to see the difference between the results within the unfocussed raw data and the range compressed data (Fig.18).

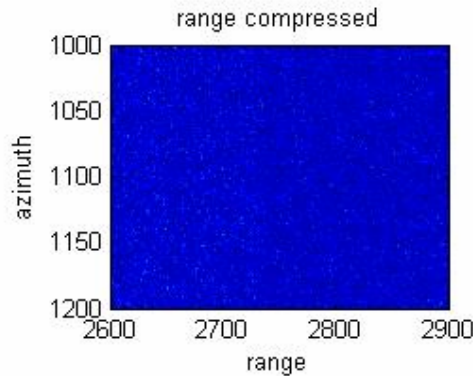

Fig.18

After plotting the image focussed in range, now it is time to generate the azimuth reference function. With the parameters defined in the beginning in the command window, number of rows, pulse repetition frequency, Doppler frequency centroid calculated also in the command window, and the Doppler frequency rate, now we are able to create the reference azimuth chirp and its Fourier transform.

The first thing to do to create the azimuth reference function, will be to make the number of azimuth odd. By using the function of MATLAB min (function which returns the array of the same size of the input array, but with the smallest element taken from each) we make the variable npts odd. The inverse of the sampling frequency is also calculated. Then if the modulus between the npts and 2 is 0 we have to add 1. To compute the azimuth chirp function the same process as to compute the range reference function is done. The odd value is divided by two and assigned to another variable. The variable t for each case it will be the result of multiplying the inverse of the sampling rate for the array which goes from the minus value calculated before to the plus value. The phase for each case is the result of multiplying 2 by pi and the centroid frequency Doppler by t plus pi by Doppler frequency rate by t^2 . Each value will be by using the function of MATLAB exp (which returns the exponential for each element) multiplied by i. Once this is done, the fast Fourier transform is done for each value of the matrix.

Then we take the column-wise fft of the range-compressed data acquired from the SAR file and multiply each value with the azimuth reference function just described. Once this is done the inverse fast Fourier transform must be applied in the values generated before.

To finish now we just have to plot again the data and obtain the expected image focussed in range and azimuth. And the SLC image can be seen (Fig.19).

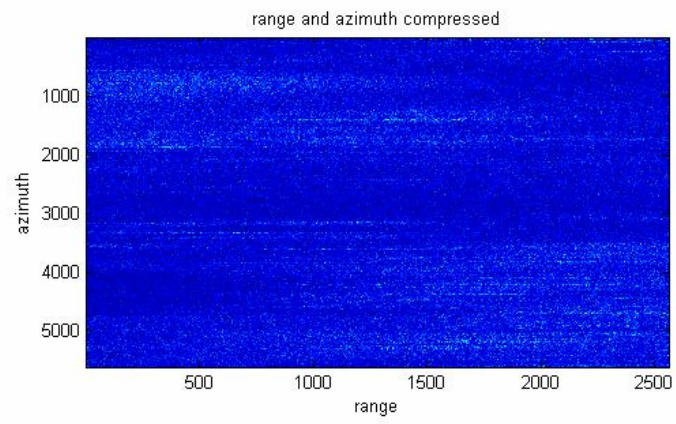

Fig.19

CHAPTER 4: CONCLUSIONS AND RECOMMENDATIONS

4.1.- CONCLUSIONS

To conclude this project the personal global evaluation must be done. The aim of this project was to get the SLC image from the RAW data and study MATLAB possibilities.

The field of satellites and the acquisition of data it is tremendous. Checking all the webs to get information which has been written in this project, one can realize that it is a quite recent investigation field, either for NASA and the ESA, the two biggest platforms which have been visited. For both organizations, SAR data acquisition it is one of the most important fields right now which are on development. That it is because the applications SAR provides to the investigators it is so wide, that it is useful for any investigation field. In the oceans, SAR data can provide information about seepage from oil deposits, bottom topography, foliage and ground penetration, moving target indication, navigation and guidance, Interferometry (3-D SAR), reconnaissance, surveillance and targeting... and so on. All these fields can make use of the SAR possibilities, so the interest it has provide to any kind of investigators it is quite obvious.

From my point of view, I think that the code in MATLAB provided, it is done for a specific file, with specific characteristics. Sure that a project in which the parameters, for each SLC we expect to obtain, it is done right now. This project it is quite specific for the data downloaded, so the possibilities of survival for this code are limited.

It was really interesting to understand all the process which must be done to obtain the SLC image, from the data acquired from a satellite. Thanks to this project, I have been able to understand all the complex process the data must get through to obtain some results. According to the Doppler frequency, in this project I have been able to have a wider view rather than the one I get in the university about this subject. Being able to understand and moreover codify the process which affects a wave due to the movement of the emitter or the receiver.

The fact of understanding all the parameters which must be set in the MATLAB code, it is a relay interesting field. The mix between the theory part of the documentation plus the MATLAB code, I consider it is a really interesting way to understand the satellites functions provided in the code, and how the theory can give expression to the code.

Talking about the difficulties found during all the procedure of this project, the most important was the data acquisition. There are several places to obtain the data from, but according to the code provide, this had its own parameters, so the data had to have the same characteristics. Checking the web site of ESA I have been able to understand the parameters which are specified for the kind of file downloaded, assuming which part of the file contain, the data, what kind of data, the usefulness of the data, by setting the parameters in the code, and the data on its own. The professor which provide the code in MATLAB to work with, help me through the process to obtain the proper data to work with and explained all kind of details to get the expected results.

As during the process of acquiring the data the use of another program was needed, I also get into the UNIX environment, in which I haven't used to work much as exception to some subjects in the university talking about LINUX. The environment it is similar and the possibilities it offers are so wide it would be impossible to describe all of them here. As the program described contains the parameters to process all the data (the file was 300MB) in my case I couldn't process so many data due to the big memory space needed in the computer, so it caused some problems due the parameters written in the program where for all that amount of information. Nevertheless, observing all the important things which could be done in the shell of the Cygwin program one can realize that the use of Windows it is quite limited compared to the UNIX environment.

Referring to the file which was downloaded, I had to realise that in the file, each row contain 11646 bytes, of those the first 412 bytes were the timing (part of the file which contains

the information needed to define all the variables in the MATLAB code) and the other 11232 bytes are the I and Q data. So in the program the first 412 bytes must be skipped

According to the code in MATLAB, once you realize the theory part, the functions and the code described are quite easy to understand and program. The use of the fft in the MATLAB, it is quite easy for the program, and the results are awesome. The part of the code which would be much difficult to understand it is the azimuth reference function (the one that involves the Doppler frequency). According to my point of view, the most difficult part to process the data would be the difficulties that the treatment of the range migration data involves. The process due to focus the image in the correct cell it is quite complicated. To calculate the range migration, the calculation which must be done, involves the second derivative of the range respect the slow time of the velocity of the spacecraft to determine the parabola described for it.

One part also to consider it is the wide part of memory MATLAB uses to calculate the entire matrix required. In my case it was also a problem, due the virtual memory space wasn't enough to process all the data, so MATLAB requires you to delete some variables or extend the virtual memory. So some images which were displayed in the screen had to suffer a process quite slow. Each part of the program had to be executed in different moments; otherwise the virtual memory couldn't compute all the data at the same session.

To summarise, I would say that this project has been really interesting to study; due it contains the mathematical part and the programming part to understand the whole of the SAR acquisition data and the process to visualize it. Moreover I consider myself able to apply lots of part of the knowledge acquired in the career to find out all the problems and solutions during all the projects process, letting me know a really interesting part of the applications of the contents of my career.

4.2- RECOMMENDATIONS

The mainly recommendations I would do about this project for the next people who can be interested on would be the study and creation of a code which is not specified in a concrete data. The fact that this project was based on the study of a specified code, which didn't contain any kind of choice to modify the parameters of the spacecraft in which the data was acquired, limited the code. The creation and analysis of a code which could acquire the parameters of the data downloaded (the information provided on the 412 first bytes of each row) would be really recommended, due the web it is full of any kind of data which can be acquired from several links, with data acquired in different places, and for several years. The fact of creating a code which could be used with any of the data downloaded would be really satisfactory and useful, but it is also important to realise that every image has its own characteristics, due the calculation of the Doppler Centroid frequency depends on several parameters during the acquisition of the data.

REFERENCES

- [1] .- <http://www.ob-ultrasound.net/radar.html> [4-05-07 time of access]
- [2] .- http://www.ittc.ku.edu/publications/documents/Allen1995_Allen1995GRSSNpp6.pdf [4-05-07 time of access]
- [3] .- Author J.C. Toomay
Radar for the Non-Specialist
1998
Bellingham, Washington: SPIE – The International Society for Optical Engineering
ISBN 1-891121-02-2
- [4] .- <http://www.kettering.edu/~drussell/Demos/doppler/doppler.html> [4-05-07 time of access]
- [5] .- <http://epsilon.nought.de/> 'Short overview on SAR remote sensing' by Andreas Reigber [4-05-07 time of access]
- [6] .- <http://www.esa.int/esaCP/index.html> [4-05-07 time of access]
- [7] .- William J.Palm III
Introduction to MATLAB 7 for Engineers
2005
1221 Avenue of the Americas, NY, The McGraw-Hill Companies, Inc.
ISBN 007-123262-1
- [8] .- <http://www.mathworks.com/products/matlab/functionlist.html> [4-05-07 time of access]
- [9] .- <http://topex.ucsd.edu/insar> [4-05-07 time of access]
- [10] .- <http://envisat.esa.int/dataproducts/asar/CNTR2-6.htm> [4-05-07 time of access]
- [11] .- <http://earth.esa.int/rootcollection/sysutil/sarraw.html> [4-05-07 time of access]

APPENDIX

This part of the project will provide the reader about some useful information to understand the whole project on its own.

The code in MATLAB referred to:

```
% *****
function [cref,fcref]=rng_ref(nfft,fs,pulsedur,slope)
%
% routine to compute ERS chirp and its fourier transform
%
% input
% fs - sampling frequency, ts=1./fs
% pulsedur - pulse duration
% slope - chirp slope
%
% set the constants and make npts be odd
%
npts=floor(fs*pulsedur);
ts=1./fs;
if(mod(npts,2.0) == 0.0)
npts=npts+1;
end
%
% compute the reference function
%
npt2=floor(npts/2.);
t=ts*(-npt2:npt2);
phase=pi*slope*t.*t;
cref1=exp(i*phase);
%
% pad the reference function to nfft
%
cref=[cref1,zeros(1,nfft-npts)];
%
% compute the fourier transform
%
fcref=fft(cref)/nfft;
% *****
function [cazi,fcazi]=azi_ref(nazi,PRF,fdc,fr)
%
% routine to compute ERS azimuthal chirp and its fourier transform
%
% input
% nazi - number of points in azimuth
% PRF - pulse repetition frequency, ts=1./PRF
% fdc - doppler centroid frequency
% fr - doppler frequency rate
%
% set the constants and make npts be odd
%
npts=min(nazi-1,1296);
ts=1./PRF;
if(mod(npts,2.0) == 0.0)
npts=npts+1;
end
%
% compute the azimuth chirp function
%
npt2=floor(npts/2.);
t=ts*(-npt2:npt2);
phase=-2.*pi*fdc*t+pi*fr*t.*t;
cazi1=exp(i*phase);
```

```

%
% pad the function to nfft
%
cazi=[cazi1(npt2:npts),zeros(1,nazinpts),
cazi1(1:npt2-1)];
%
% compute the fourier transform
%
fcazi=fft(cazi)/nazi;
%*****
function [csar,nrow,ncol]=read_rawsar(sar_file)
%
% routine to read and unpack ERS SAR data in DPAF format
%
fid=fopen(sar_file,'r');
%
% read the bytes
%
[sar,nsar]=fread(fid,'uchar');
sar=reshape(sar,11644,nsar/11644);
nrow=nsar/11644;
ncol=5616;
st=fclose(fid);
%
% extract the real and imaginary parts
% and remove the mean value
%
csar=complex(sar(413:2:11643,:)-15.5,sar(414:2:11644,:)-15.5);
%
%*****
% matlab script to focus ERS-2 signal data
%
% set some constants for e2_10001_2925
%
% range parameters
%
rng_samp_rate = 1.896e+07;
pulse_dur = 3.71e-05;
chirp_slope = 4.1779e+11;
%
% azimuth parameters
%
PRF=1679.902394;
radar_wavelength=0.0566666;
SC_vel=7125.;
%
% compute the range to the radar reflectors
%
near_range=829924.366;
dr=3.e08/(2.*rng_samp_rate);
range=near_range+2700*dr;
%
% use the doppler centroid estimated from the data and the
% doppler rate from the spacecraft velocity and range
%
fdc=284;
fr=2*SC_vel*SC_vel/(range*radar_wavelength);
%
% get some sar data
%
[cdata,nrow,ncol] = read_rawsar('out2.raw');
%
% make a colormap
%
map=ones(21,3);
for k=1:21;

```

```

level=0.05*(k+8);
level=min(level,1);
map(k,:)=map(k,:).*level;
end
colormap(map);
%
% image the raw data
%
figure(1)
subplot(2,2,1),imagesc(abs(cdata));
xlabel('range')
ylabel('azimuth')
title('unfocussed raw data')
axis([2600,2900,1000,1200])
%
% generate the range reference function
%
[cref,fceref]=rng_ref(ncol,rng_samp_rate,pulse_dur,chirp_slope);
%
% take the fft of the SAR data
%
fcdata=fft(cdata);
%
% multiply by the range reference function
%
cout=0.*fcdata;
for k=1:nrow;
ctmp=fcdata(:,k);
ctmp=fceref.*ctmp;
cout(:,k)=ctmp;
end
clear cdata
%
% now take the inverse fft
%
odata=ifft(cout);
clear cout
%
% plot the image and the reflector locations
%
x0=[2653.5,2621];
x0=x0+90;
y0=[20122,20226];
y0=y0-19500+427;
figure(1)
hold
subplot(2,2,2),imagesc(abs(odata));
plot(x0,y0,'o')
xlabel('range')
ylabel('azimuth')
title('range compressed')
axis([2600,2900,1000,1200])
%
% use this for figure 2 as well
%
figure(2)
colormap(map);
subplot(2,2,1),imagesc(abs(odata));
hold on
plot(x0,y0,'o')
xlabel('range')
ylabel('azimuth')
title('range compressed')
axis([2600,2900,1000,1200])
%
% generate the azimuth reference function

```

```
%
[cazi,fcazi]=azi_ref(nrow,PRF,fdc,fr);
%
% take the column-wise fft of the range-compressed data
%
fcddata=fft(odata');
%
% multiply by the azimuth reference function
%
cout=0.*fcddata;
for k=1:ncol;
ctmp=fcddata(:,k);
ctmp=fcazi.*ctmp;
cout(:,k)=ctmp;
end
%
% now take the inverse fft and plot the data
%
odata=ifft(cout);
figure(2)
subplot(2,2,2),imagesc(abs(odata));
hold on
plot(x0,y0,'o')
xlabel('range')
ylabel('azimuth')
title('range and azimuth compressed')
axis([2600,2900,1000,1200])
```

The description of the .raw file according to ESA can be checked in the following page:

<http://earth.esa.int/rootcollection/sysutil/sarraw.html>

The following web sites are considered really useful due the information which has been read help me to know more about this topic:

- <http://www.profc.udec.cl/~gabriel/tutoriales/rsnote/cp4/cp4-3.htm>
- <http://epsilon.nought.de/>
- <http://www.infosar.co.uk/docs/node7.html>
- <http://www.cv.tu-berlin.de/rat/links.php>
- http://www.ittc.ku.edu/publications/documents/Allen1995_Allen1995GRSSNpp6.pdf
- <http://southport.jpl.nasa.gov/desc/imagingradarv3.html>
- <http://earth.esa.int/applications/>
- http://ccrma.stanford.edu/~jos/filters/Nonlinear_Filter_Example_Dynamic.html
- <http://envisat.esa.int/dataproducts/asar/CNTR2-6-1-2-3.htm>
- <http://profc.udec.cl/~gabriel/tutoriales/rsnote/contents.htm>
- <http://www.ciat.cqjar.org/dtmradar/principal.htm>
- <http://www.luventicus.org/articulos/03U006/index.html>
- http://seismo.berkeley.edu/~dschmidt/ROI_PAC/
- http://www.npagroup.com/insar/whatisinsar/insar_simple.htm
- http://volcanoes.usgs.gov/insar/more_insar.html
- <http://earth.esa.int/ers/tenyears/>
- <http://www.science-and-technology.nl/beat/documentation/beat-matlab/index.html>
- <http://www.crisp.nus.edu.sg/ers/ers.html>
- <http://www.terraserver.com/providers/providers.asp>
- <ftp://ftp.ifremer.fr/./ifremer/argo/>
- <http://topex.ucsd.edu/insar/>
- http://ilrs.gsfc.nasa.gov/cgi-bin/satellite_missions/select.cgi?order=by_name&sat_code=ERS2&sat_name=ERS-2&sat_no=9502101&tab_id=general
- <http://www.ciat.cqjar.org/dtmradar/principal.htm>
- http://www.etsimo.uniovi.es/~feli/CursoMDT/Tema_2.pdf

- http://www.photoxels.com/tutorial_raw.html
- <http://earth.esa.int/pcs/ers/sar/telemetrydata/>
- <http://www.die.net/doc/linux/man/man1/dd.1.html>
- <http://www.cygwin.com/>
- <http://www.mathworks.com/access/helpdesk/help/techdoc/index.html?/access/helpdesk/help/techdoc/ref/function.html&http://www.google.es/search?hl=es&rls=GGGL%2CGGGL%3A2006-44%2CGGGL%3Aes&q=MATLAB+function+&btnG=B%C3%BAqueda&meta=>
- http://earth.esa.int/pub/software/descw/descw_if.pdf
- http://www.asi.it/html/eng/asicgs/remotesens/ers_m3.html
- http://www.asi.it/html/eng/asicgs/remotesens/e_raw.html
- <http://www.ob-ultrasound.net/radar.html>
- <http://www.kettering.edu/~drussell/Demos/doppler/doppler.html>
- <http://www.sc.ehu.es/sbweb/fisica/ondas/doppler/doppler.html>

All the websites have been visited till 4-05-07, last time of access.

In the following pages there is the information received from MATHWORKS.